

2D Schuifdeur
2P Portes coulissantes
2D Sliding doors



Opbouw met 2 personen
Montage par 2 personnes
Assembling by 2 persons

Gebruik deze handleiding van begin tot einde voor het probleemloos monteren van uw aangekocht meubel aub.

Veuillez bien suivre nos instructions ci-après lors du montage de votre meuble. Merci.

Please use the manual from the beginning until the end to assemble your newly bought furniture without troubles.

Handleiding 1

Manuel 1

Manual 1

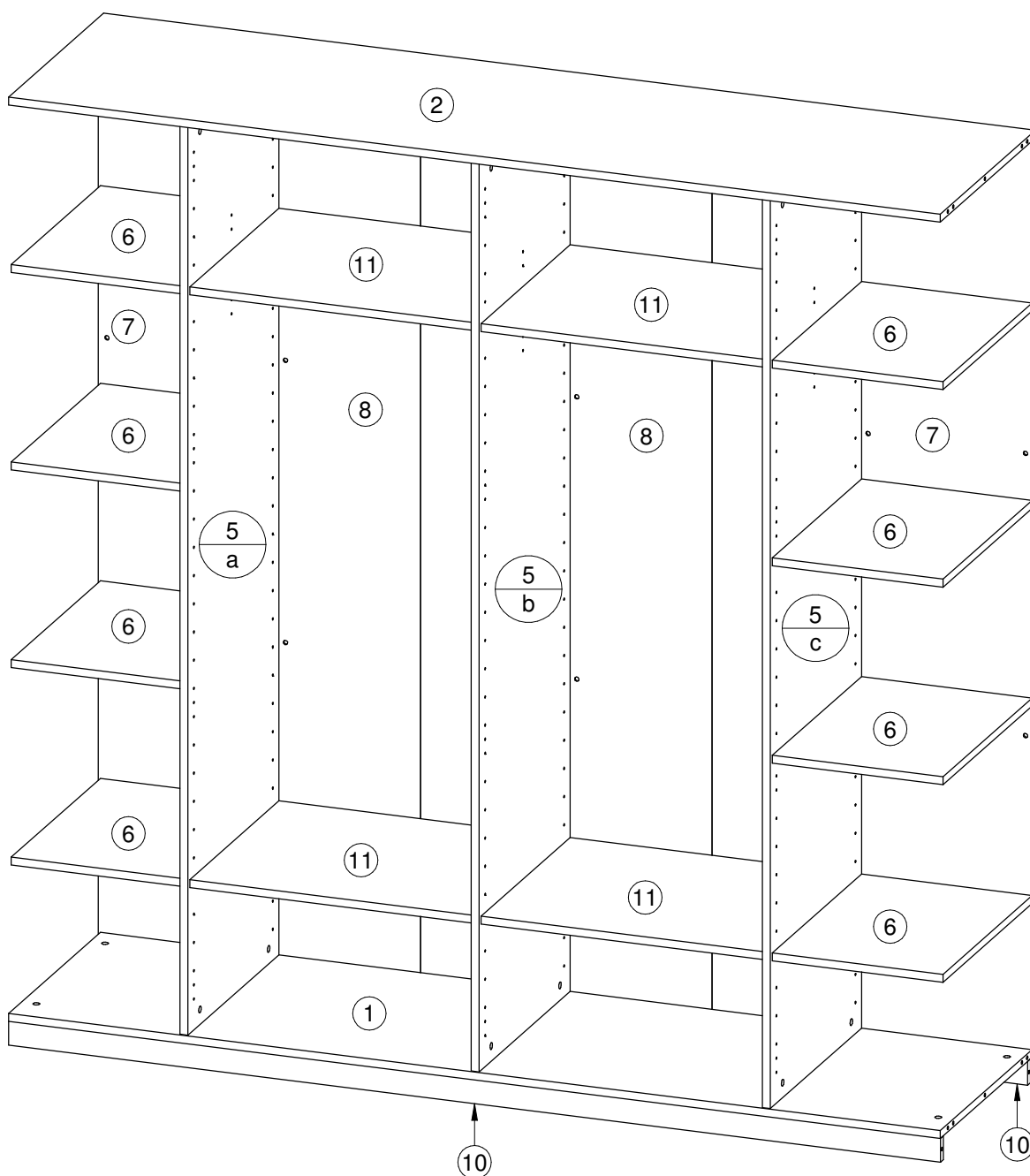
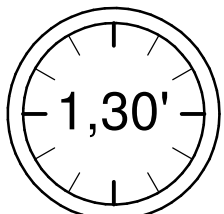
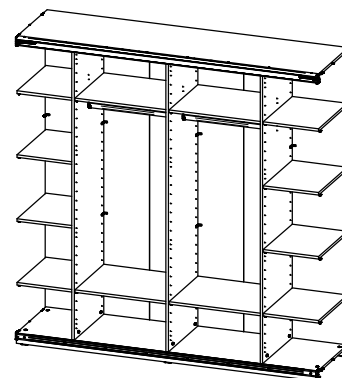

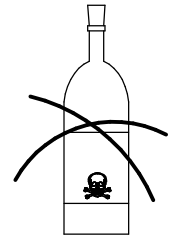
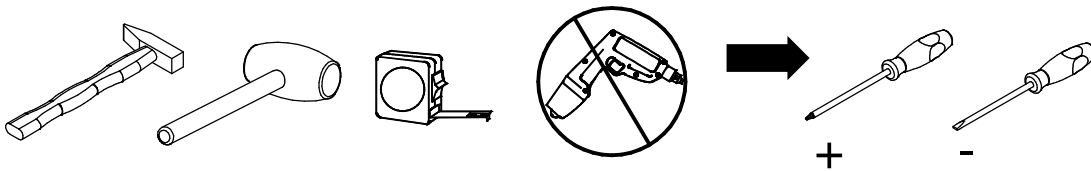

SOLVANT
DILUANT
OPLOSMIDDEL
THINNER

(FR) Entretien: utilisez un chiffon légèrement humide et séchez aussitôt. Toute trace de liquide doit être enlevé immédiatement. Meuble inadapté aux pièces humides. N' utilisez jamais du solvant, détergent, diluant, produits chimiques ou cirage. Notice du montage à conserver. Pour tous service apres-vente, rendezvous au magasin avec cette notice.

(GB) Maintenance: clean with slightly wet moistened cloth, wipe dry immediately. Wipe off wetness at once. Not suited for humid locations. Never use solvent, cleaner, thinner, chemical products or wax. Retain manual instruction. For the after sales, go back to the shop with this assembly instruction.

(NL) Onderhoud: met licht vochtige doek reinigen hierna direct droog wrijven. Vocht op het bovenblad direct opnemen. De meubels zijn niet voor vochtige ruimten bestemd. Gebruik nooit oplosmiddel, reinigingsmiddel, verdunner, chemische producten of boenwas. Montage tekening opbergen. Voor service na verkoop, ga naar uw leverancier met deze montage handleiding.

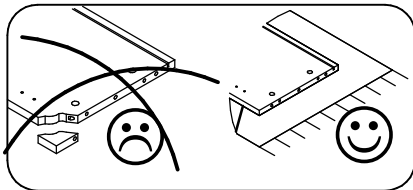

Made in Belgium

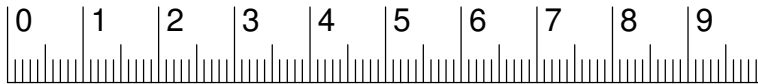
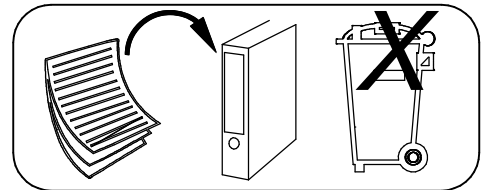

Beslagzak / sachet de quincaillerie / packet with fittings

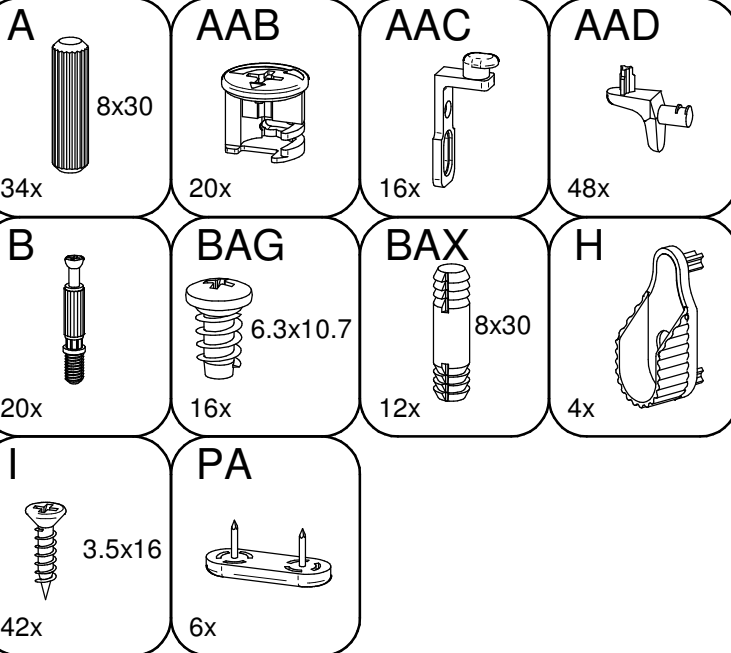

Doos 2 / boîte 2 / box 2

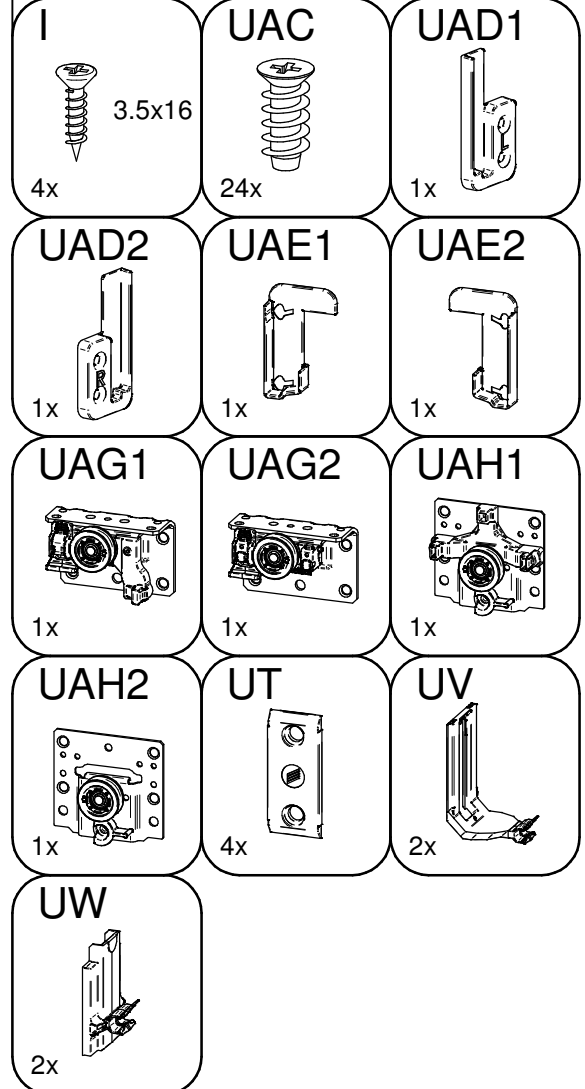

Doos 1 & 2 worden enkel gebruikt in handleiding 2 van het aangekochte meubel.

Boîte 1 & 2 sont seulement utilisées dans le manuel 2 du meuble acheté.

Box 1 & 2 are only used in manual 2 of the purchased furniture.

Doos 1 / boîte 1 / box 1

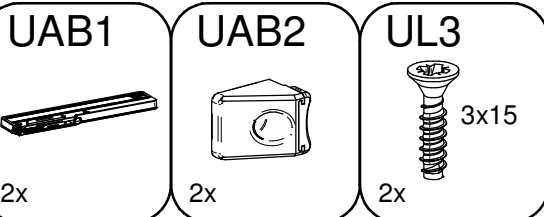

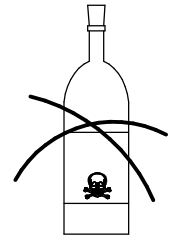
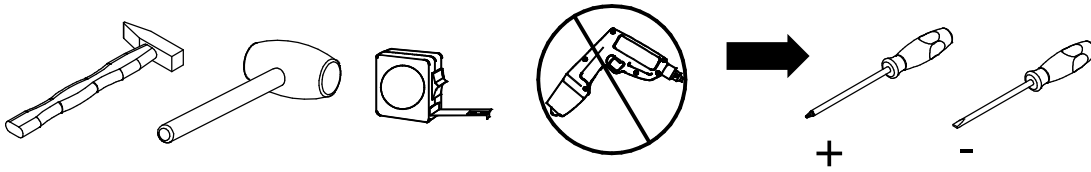

SOLVANT
DILUANT
OPLOSMIDDEL
THINNER

(FR) Entretien: utilisez un chiffon légèrement humide et séchez aussitôt. Toute trace de liquide doit être enlevé immédiatement. Meuble inadapté aux pièces humides. N' utilisez jamais du solvant, détergent, diluant, produits chimiques ou cirage. Notice du montage à conserver. Pour tous service apres-vente, rendezvous au magasin avec cette notice.

(GB) Maintenance: clean with slightly wet moistened cloth, wipe dry immediately. Wipe off wetness at once. Not suited for humid locations. Never use solvent, cleaner, thinner, chemical products or wax. Retain manual instruction. For the after sales, go back to the shop with this assembly instruction.

(NL) Onderhoud: met licht vochtige doek reinigen hierna direct droog wrijven. Vocht op het bovenblad direct opnemen. De meubels zijn niet voor vochtige ruimten bestemd. Gebruik nooit oplosmiddel, reinigingsmiddel, verdunner, chemische producten of boenwas. Montage tekening opbergen. Voor service na verkoop, ga naar uw leverancier met deze montage handleiding.

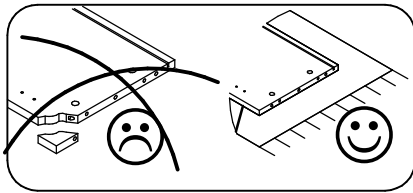

Made in Belgium

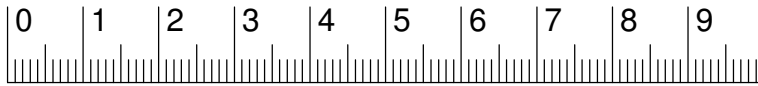
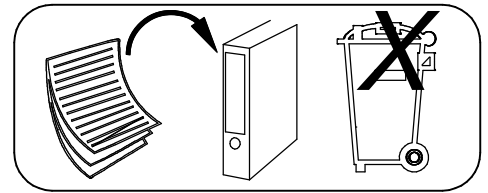

Afhankelijk van de kastbreedte (enkel nodig in handleiding 2):

Dépendant de largeur de l'armoire (seulement besoin à manuel 2):

Depends on the width of the cabinet (only needed in manual 2):

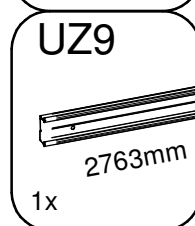
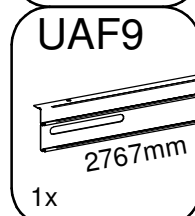
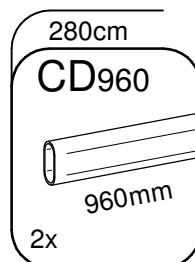
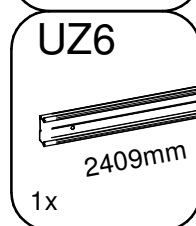
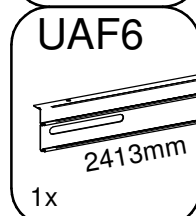
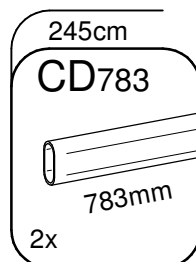
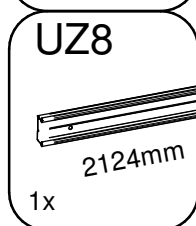
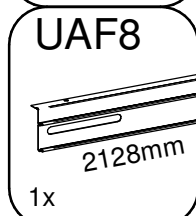
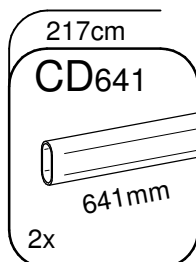

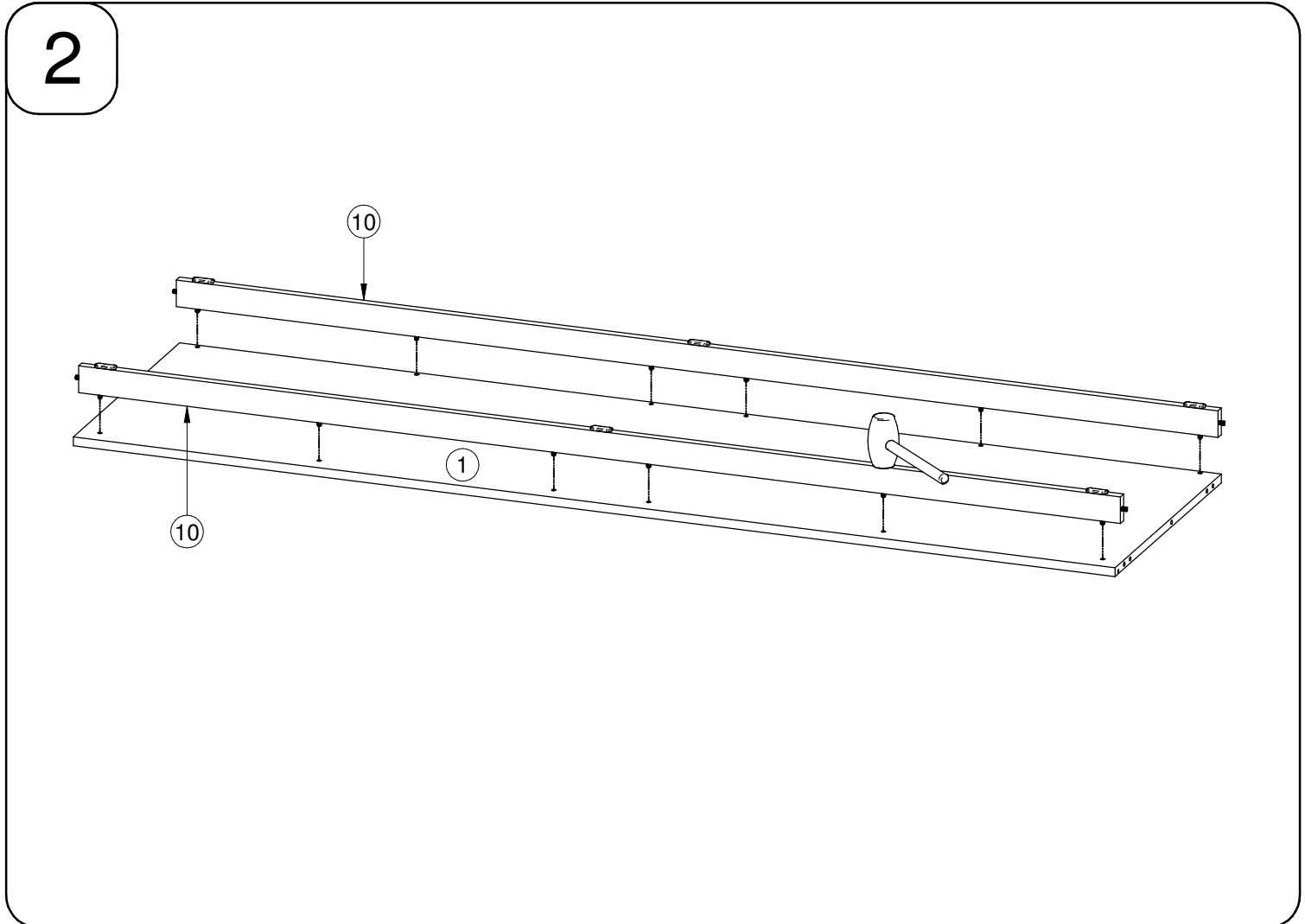
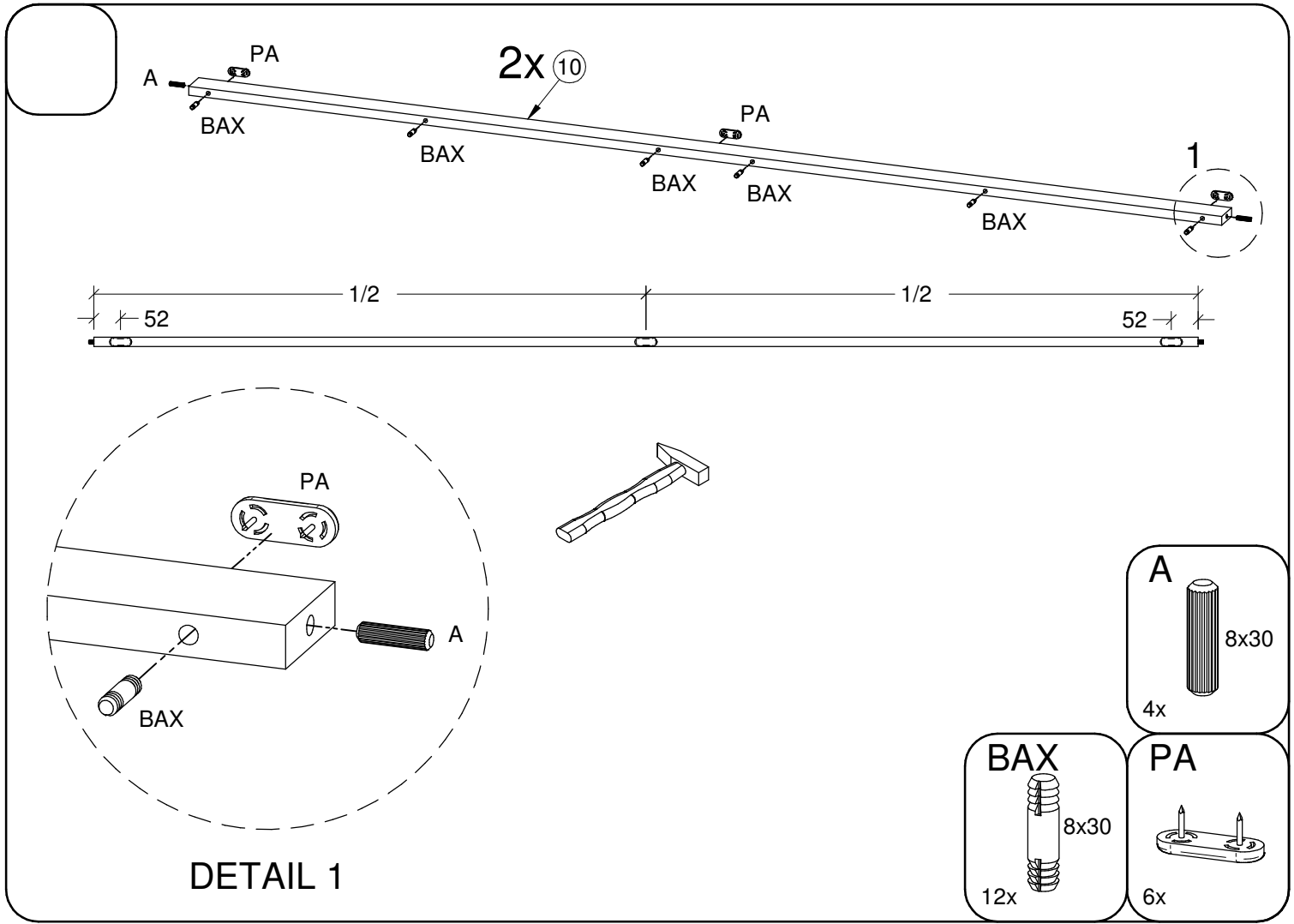

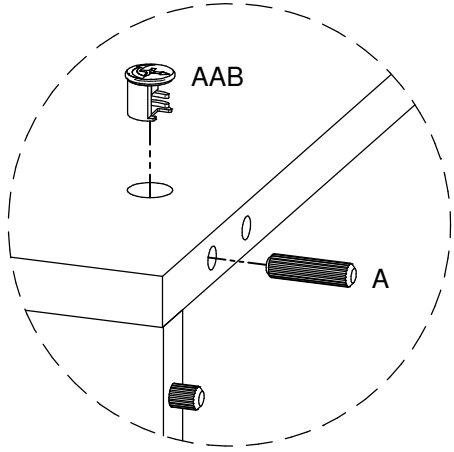
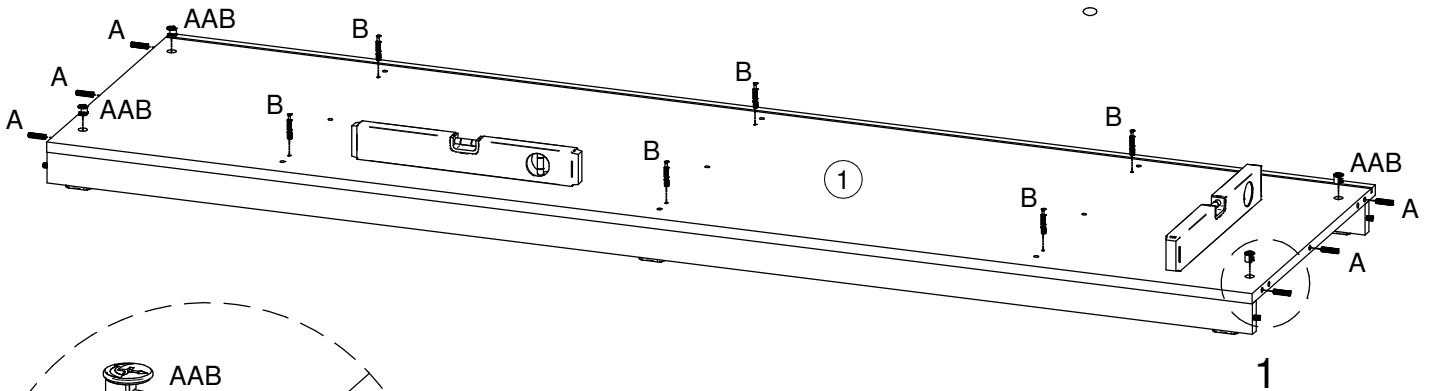
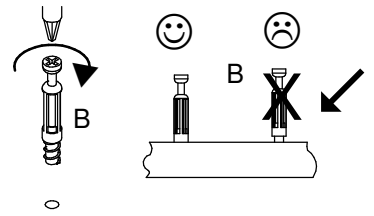
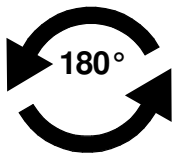

DETAIL 1

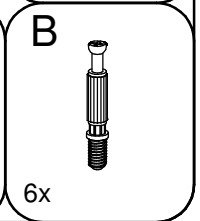
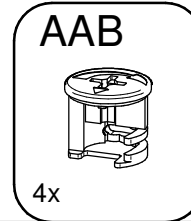
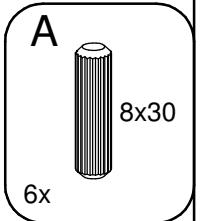

4

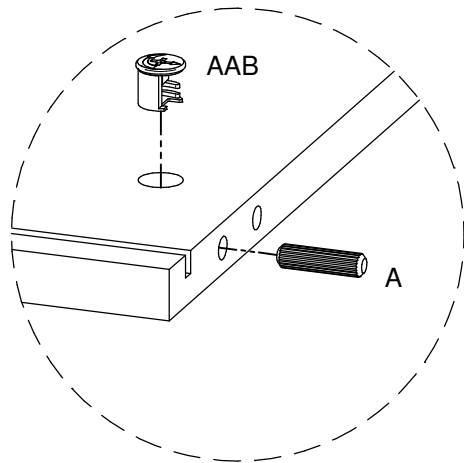
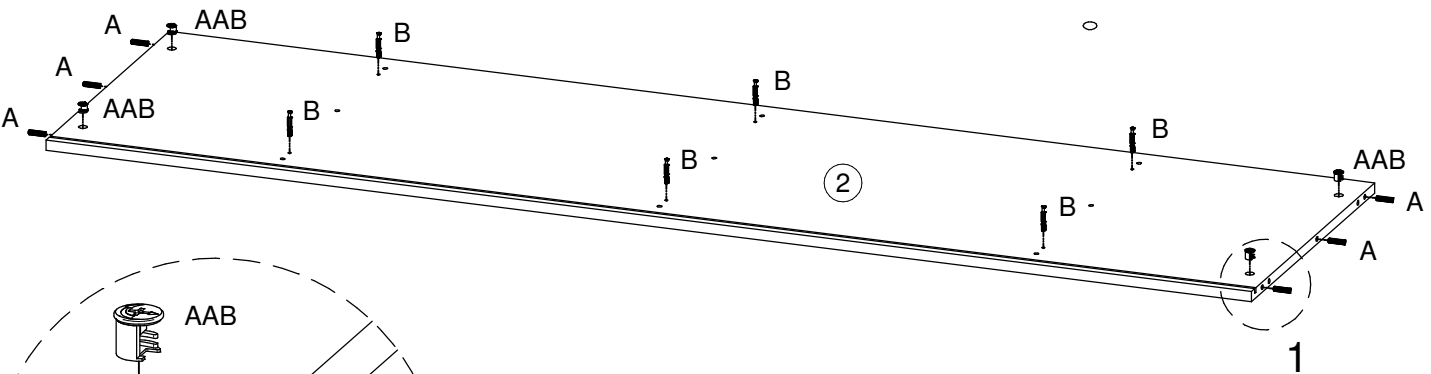
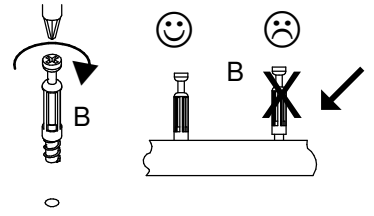

DETAIL 1

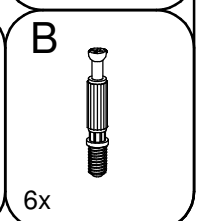
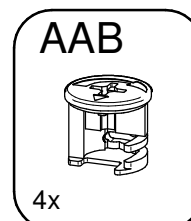
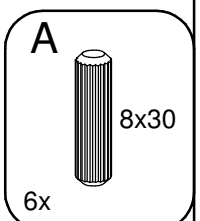

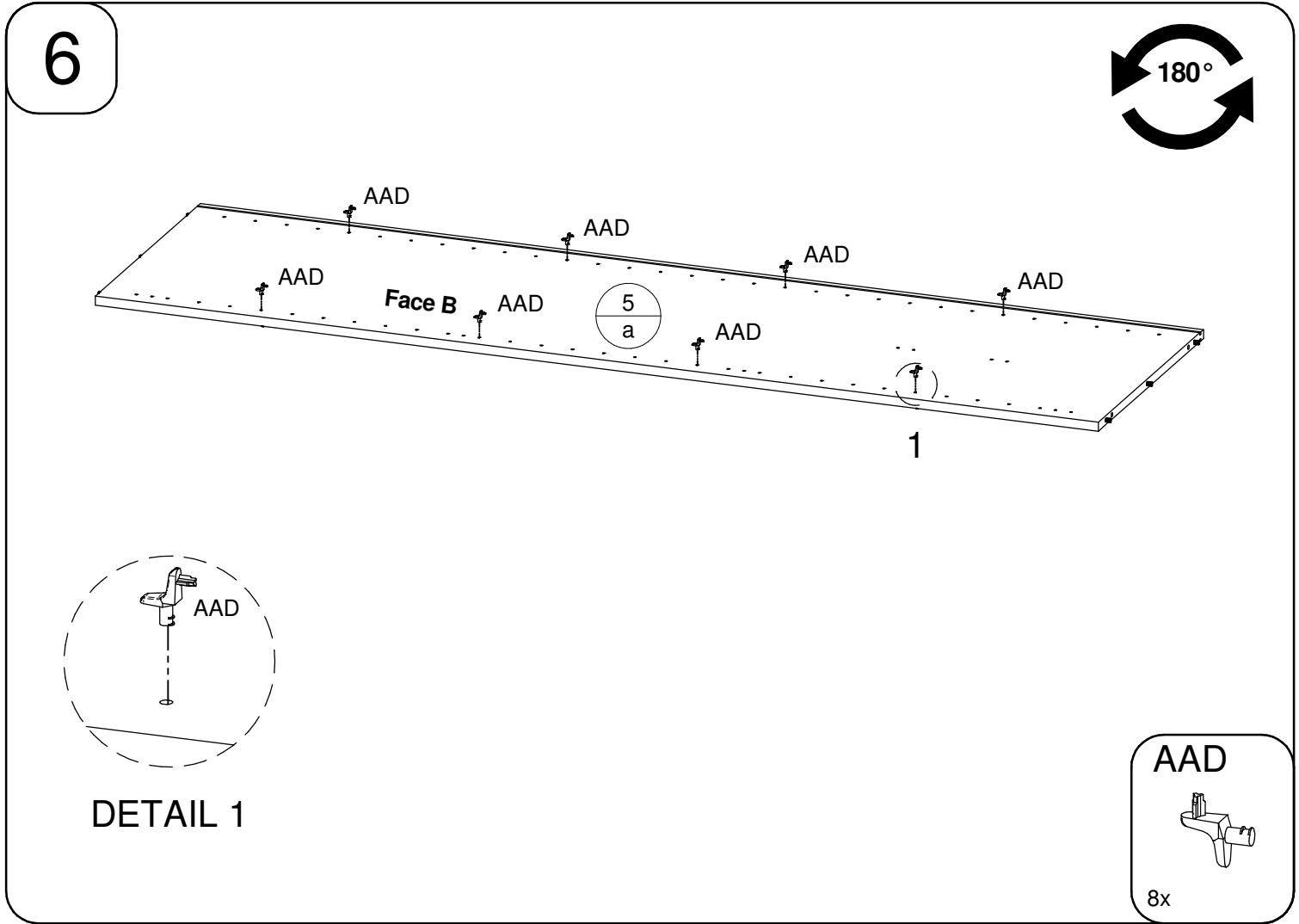
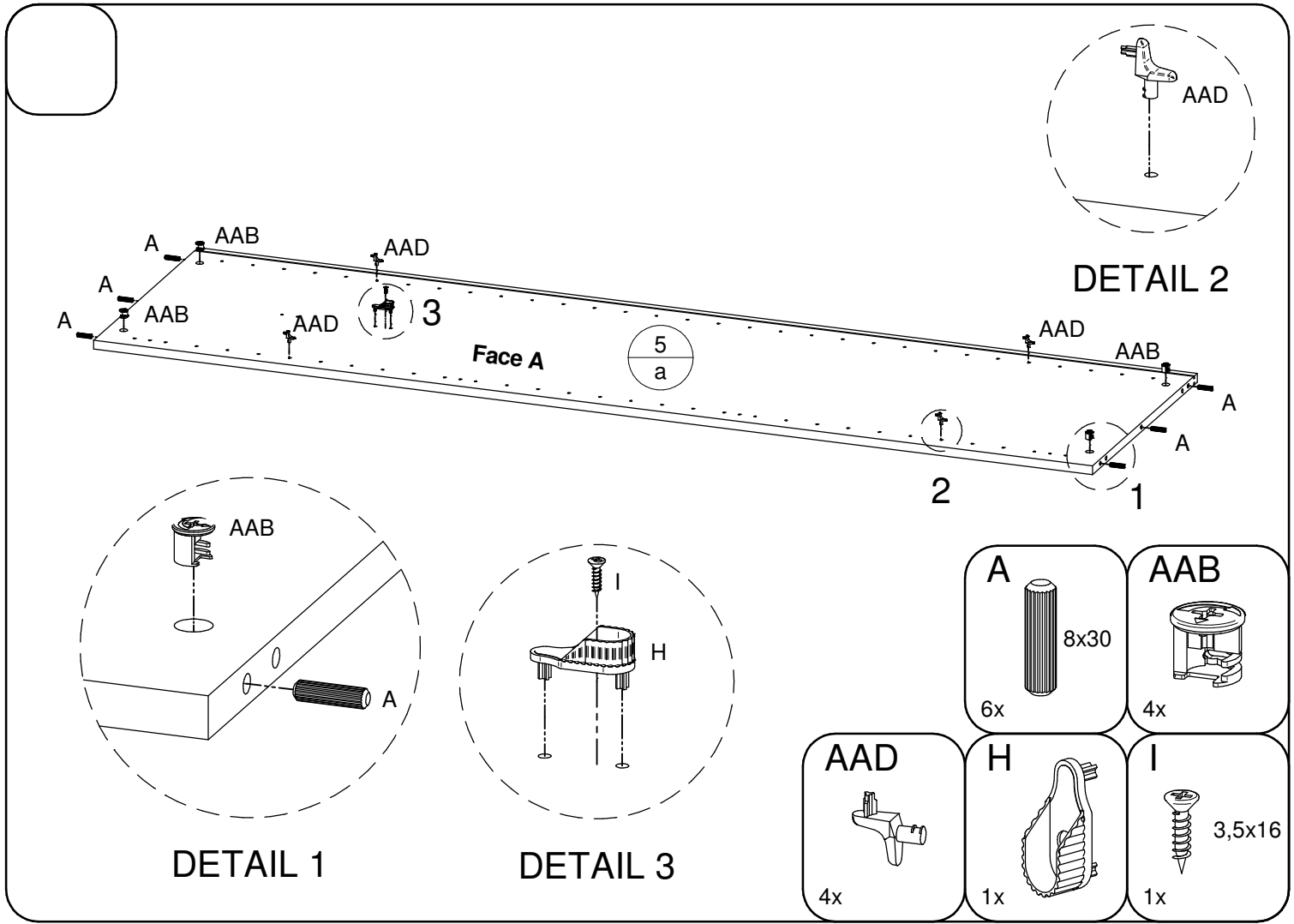

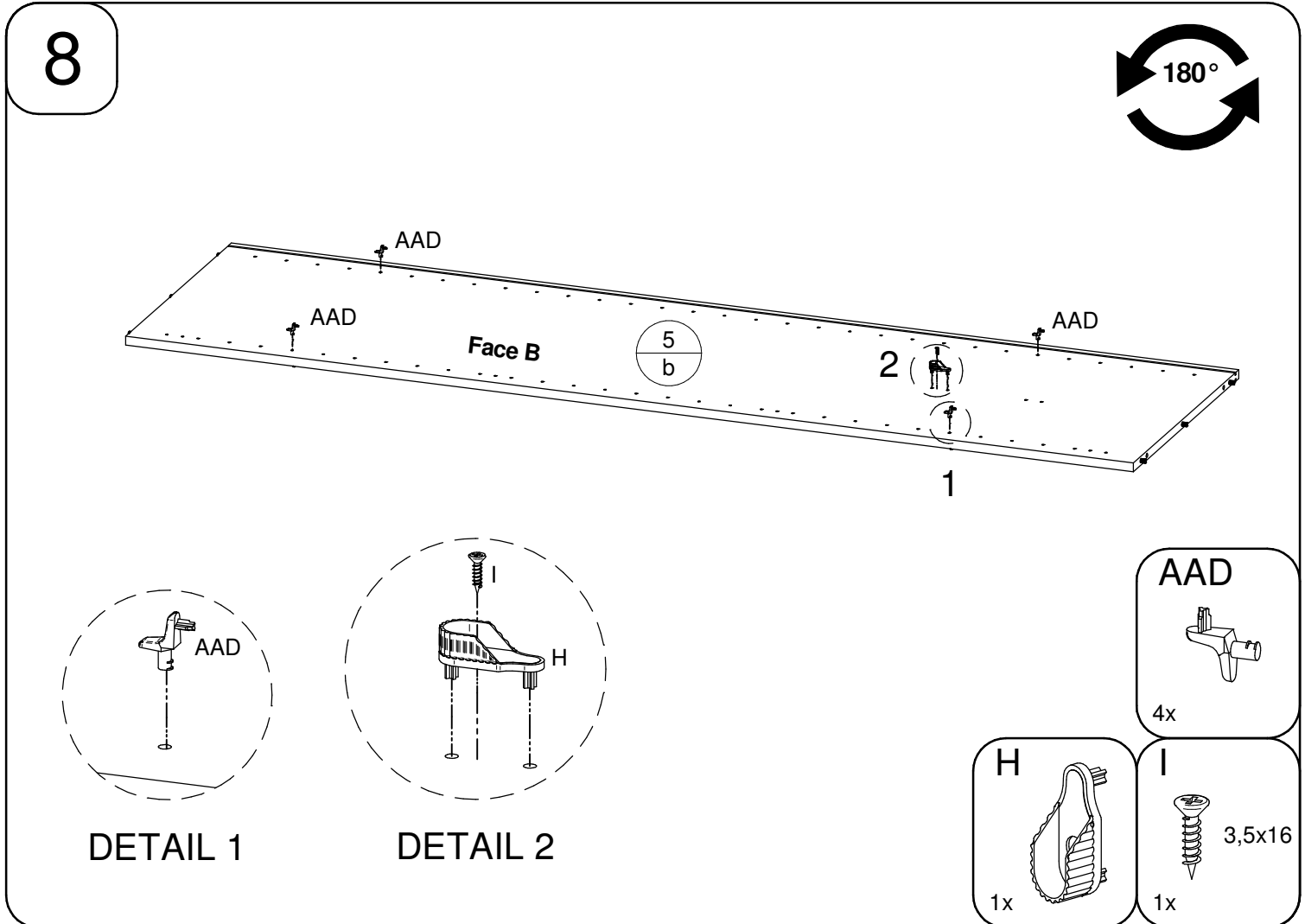
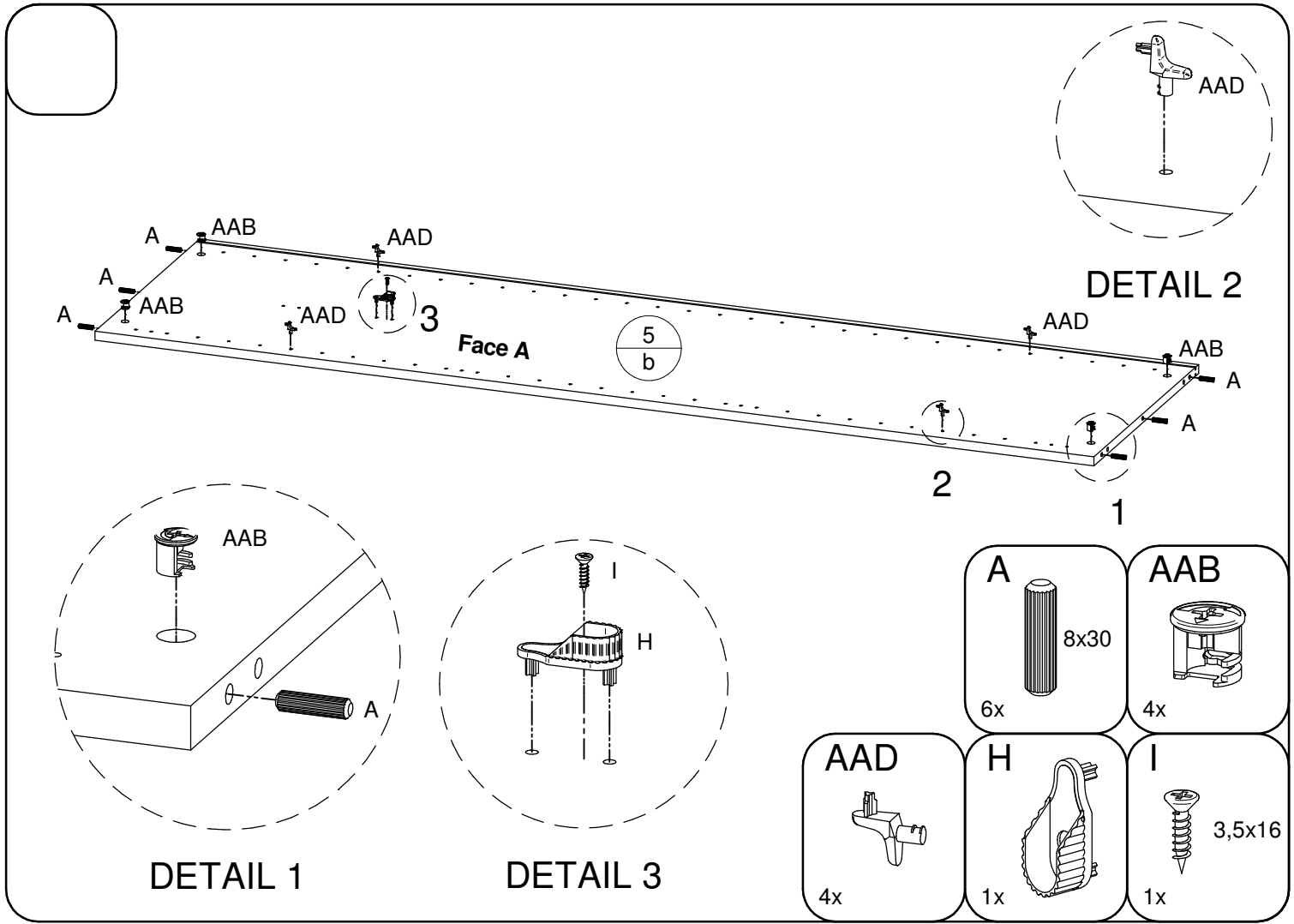

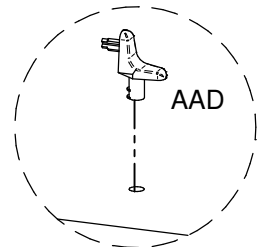

DETAIL 2

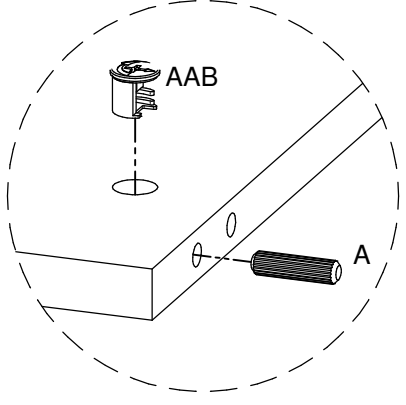
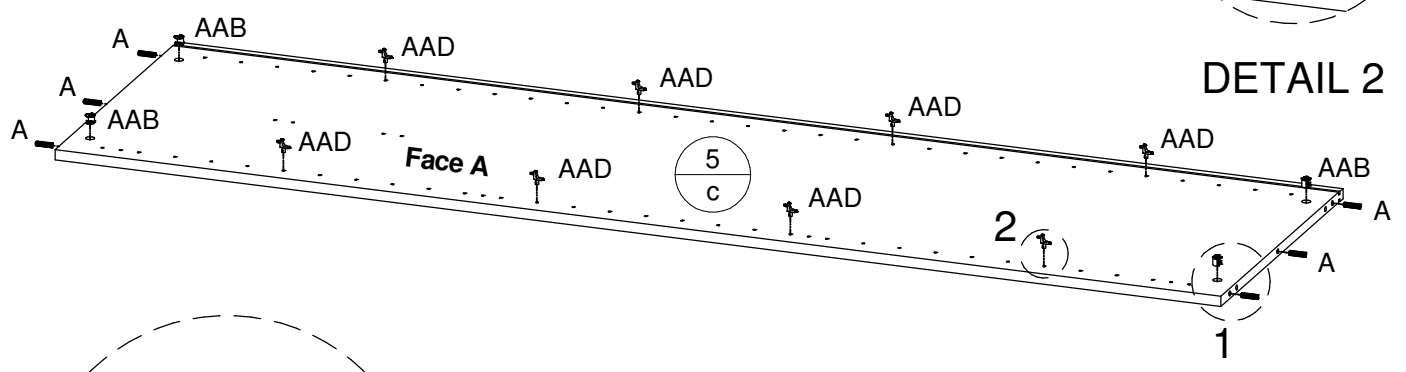

DETAIL 1

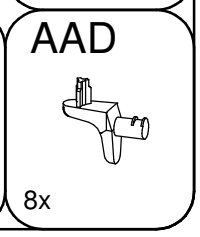
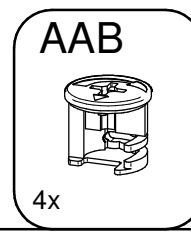
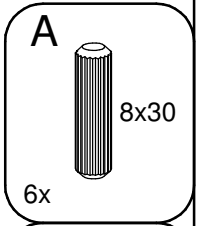

10

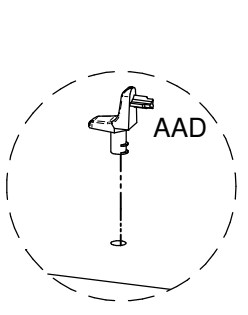
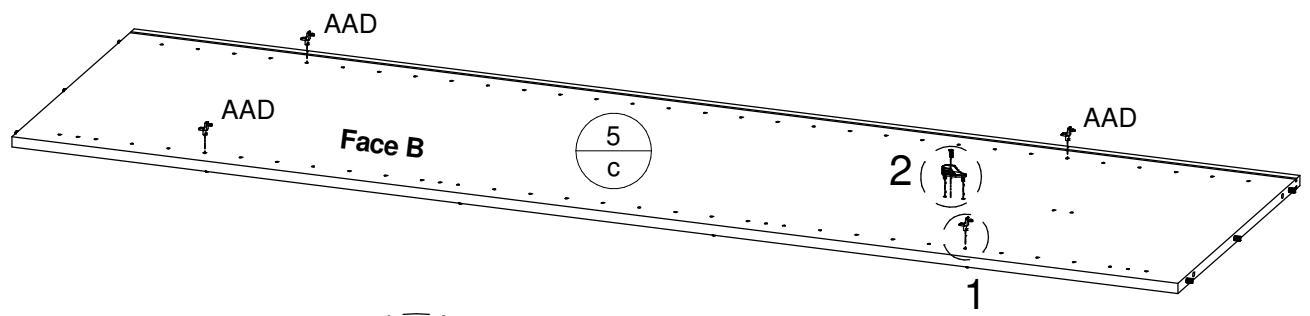
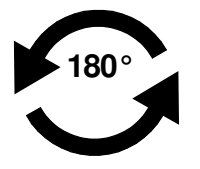

DETAIL 1

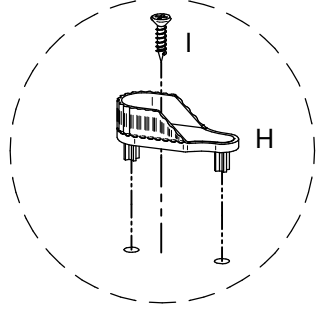

DETAIL 2

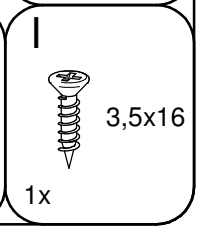
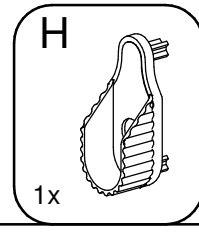
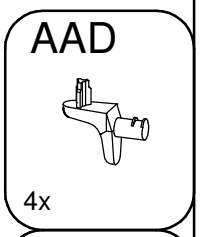

11

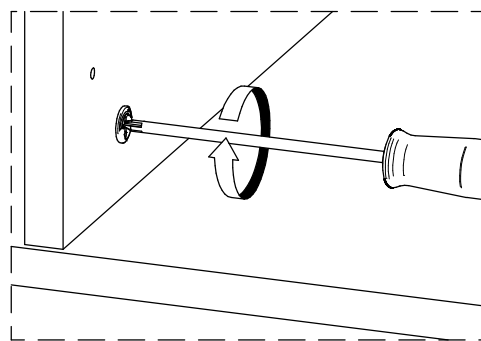
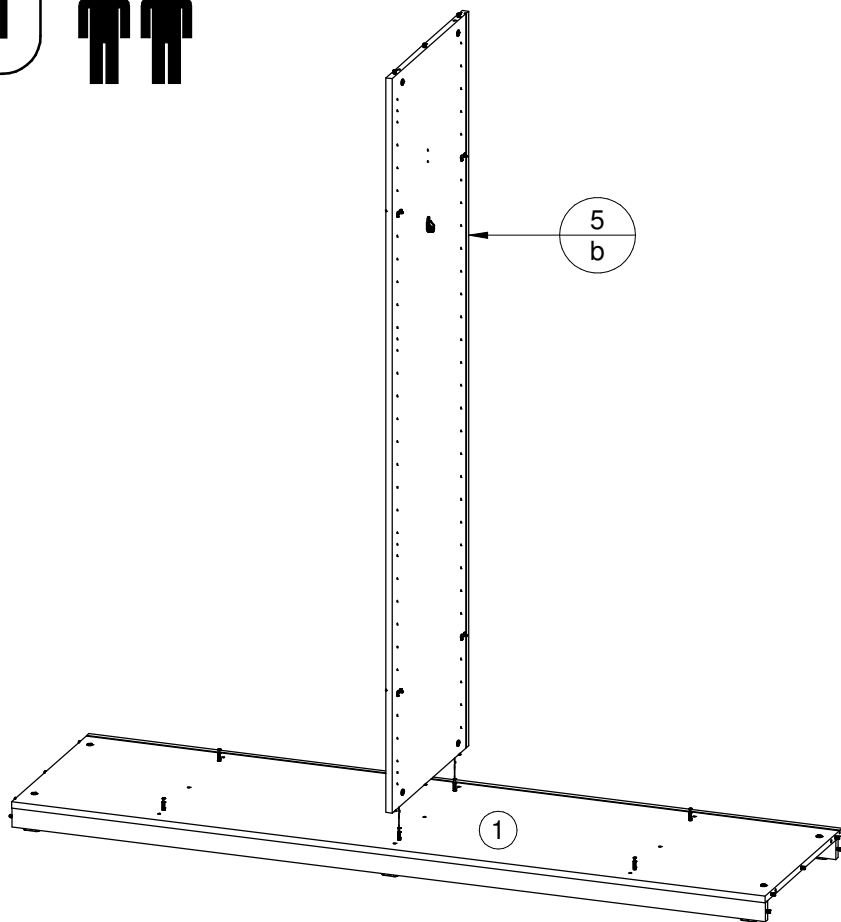

12

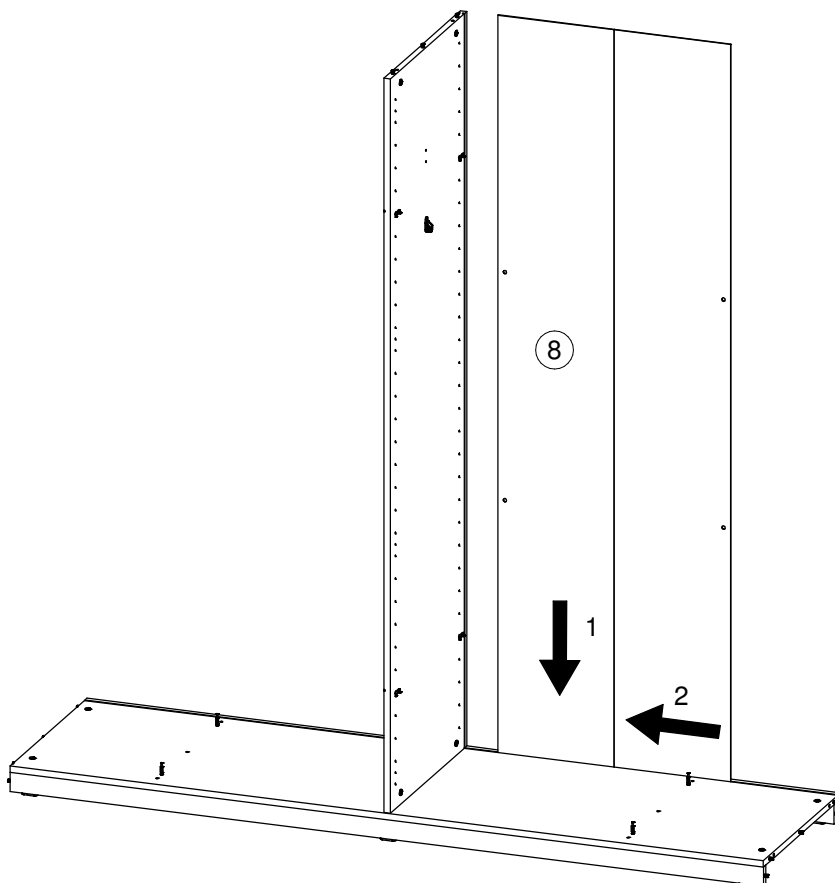

13

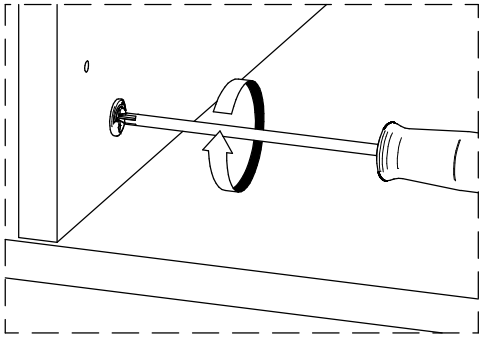
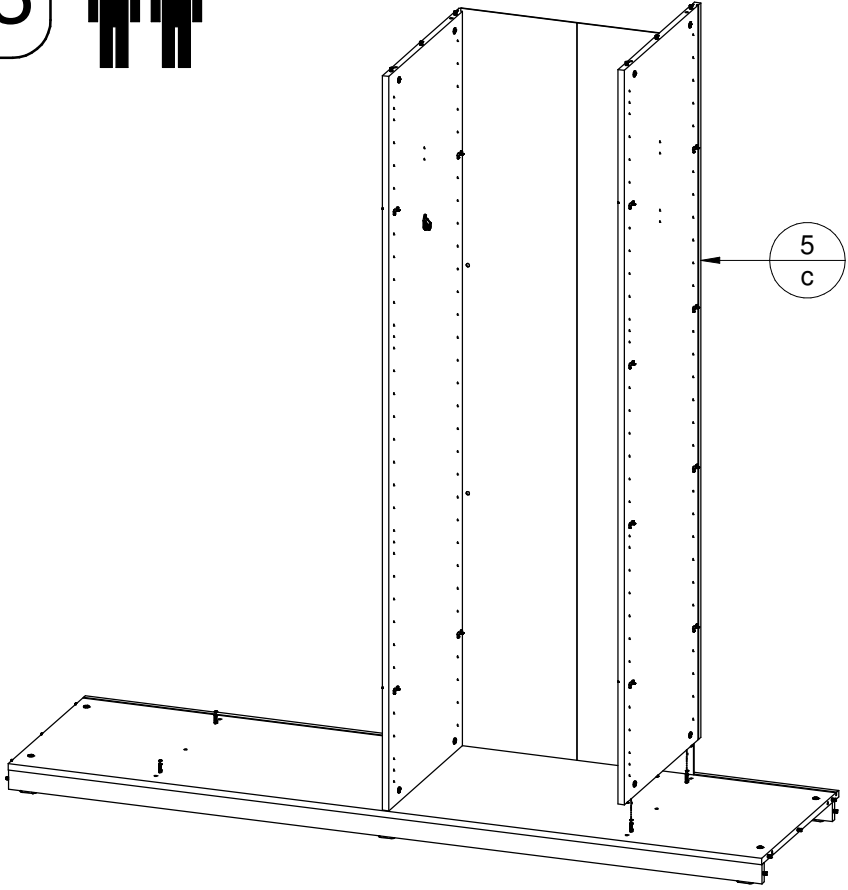

14

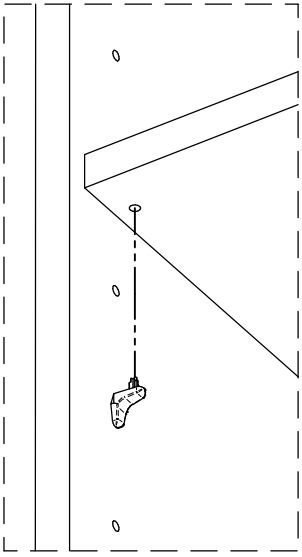
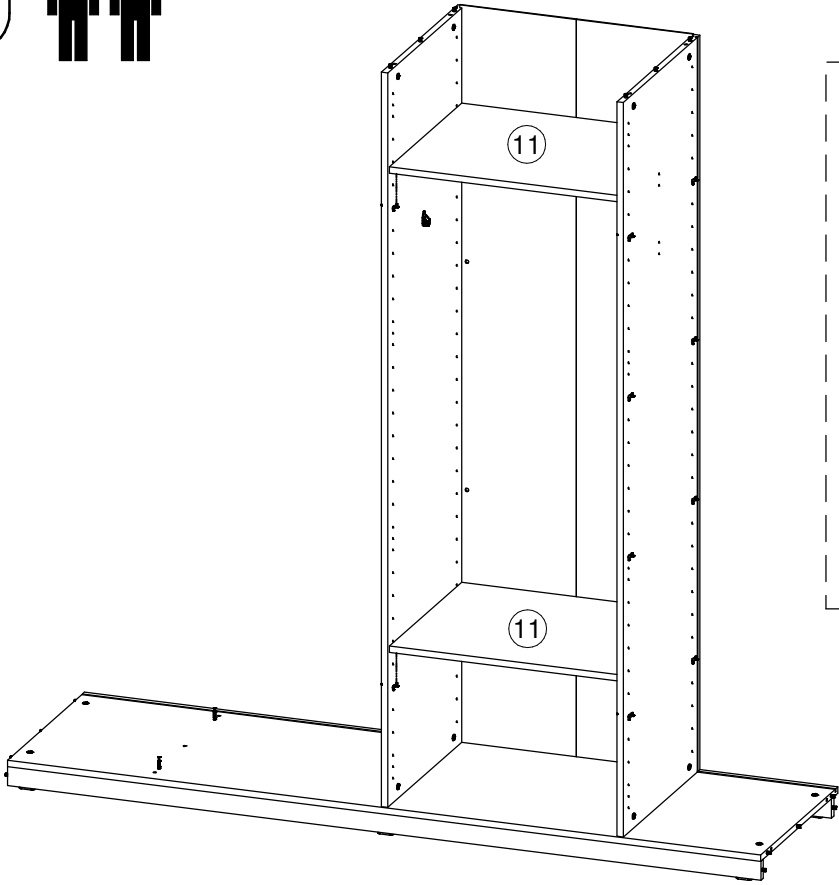

15

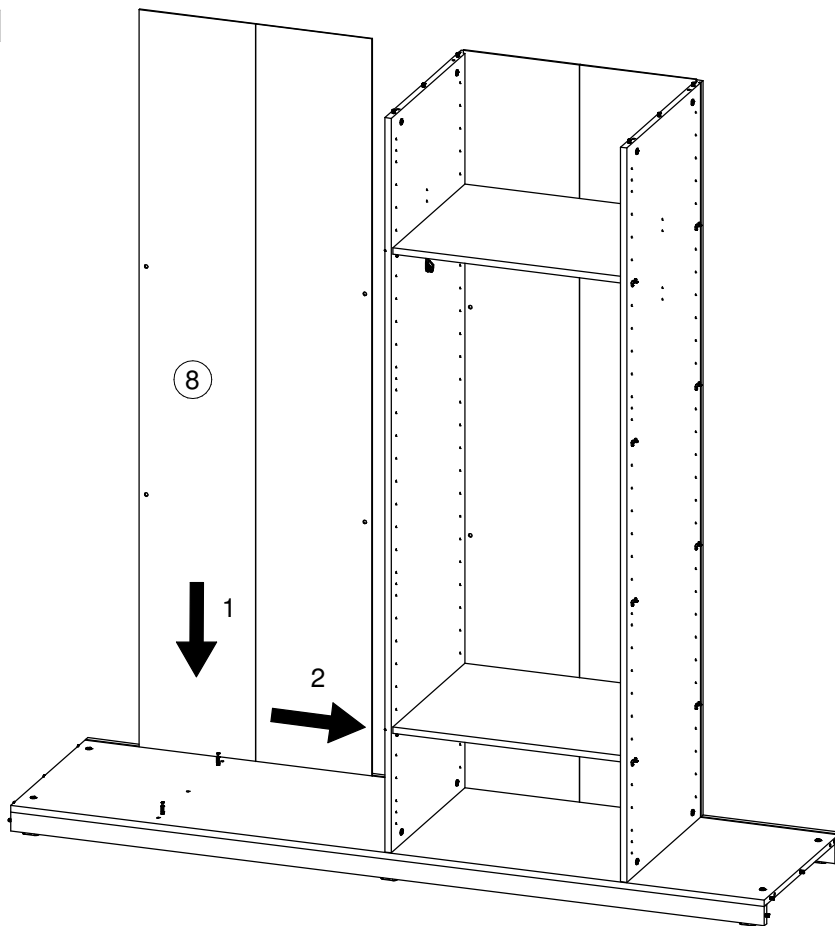

16

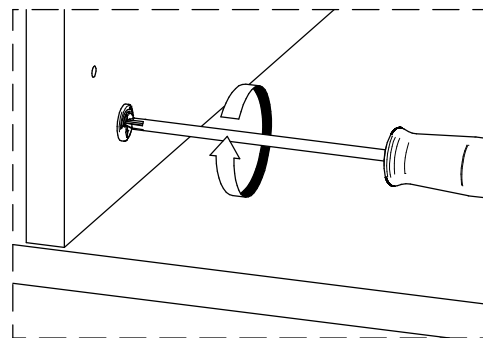
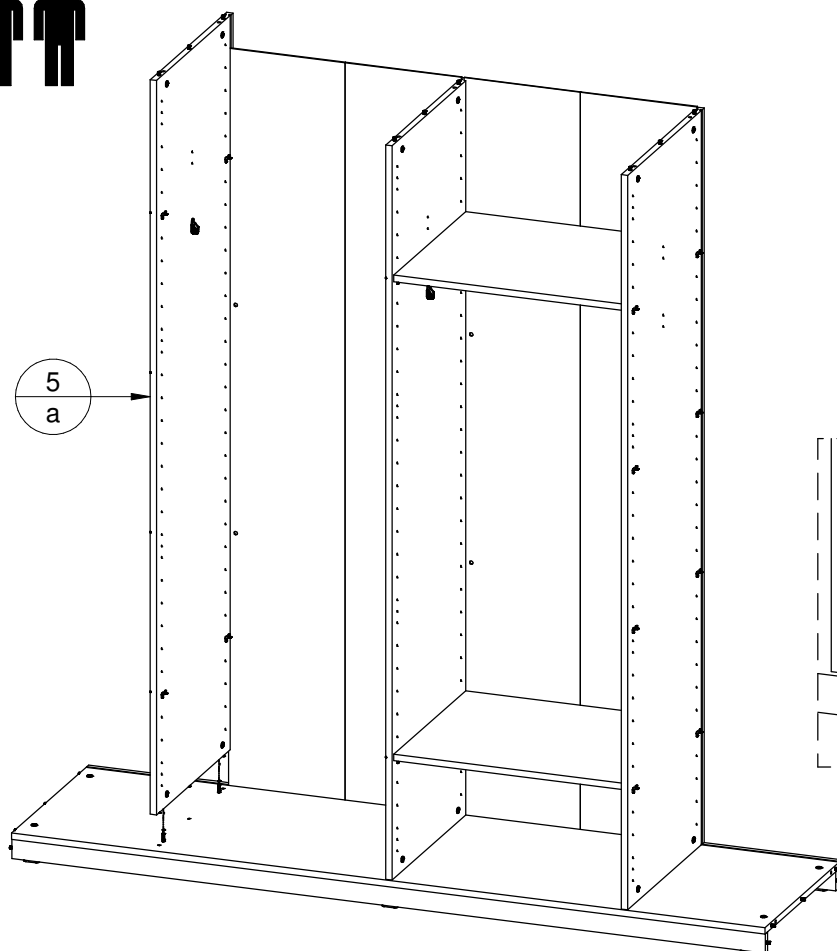

17

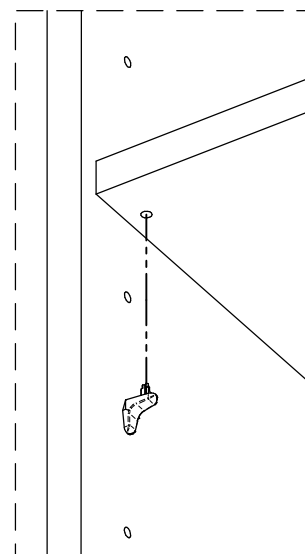
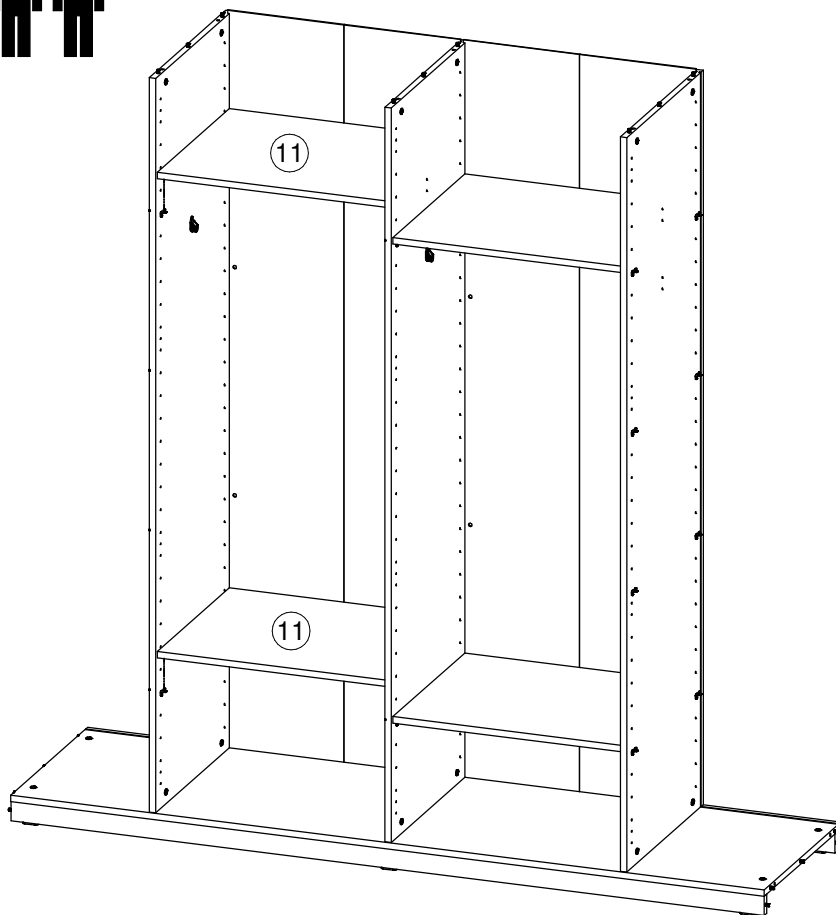

18

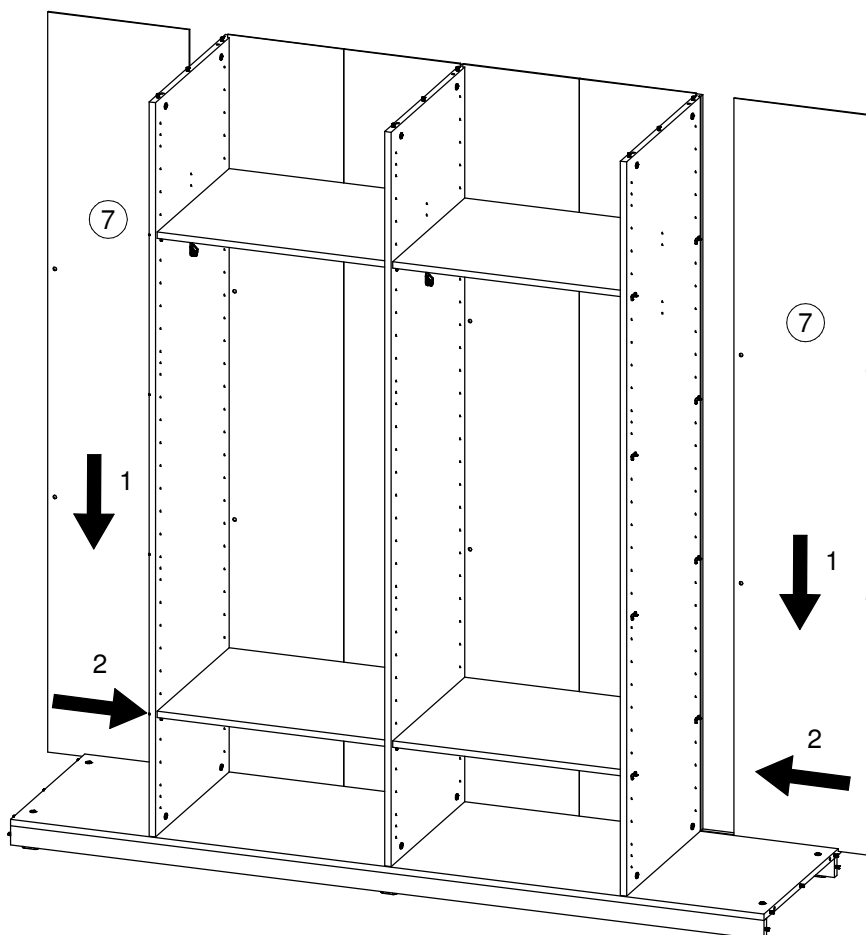

19

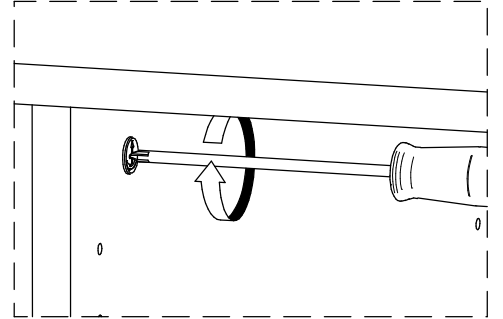
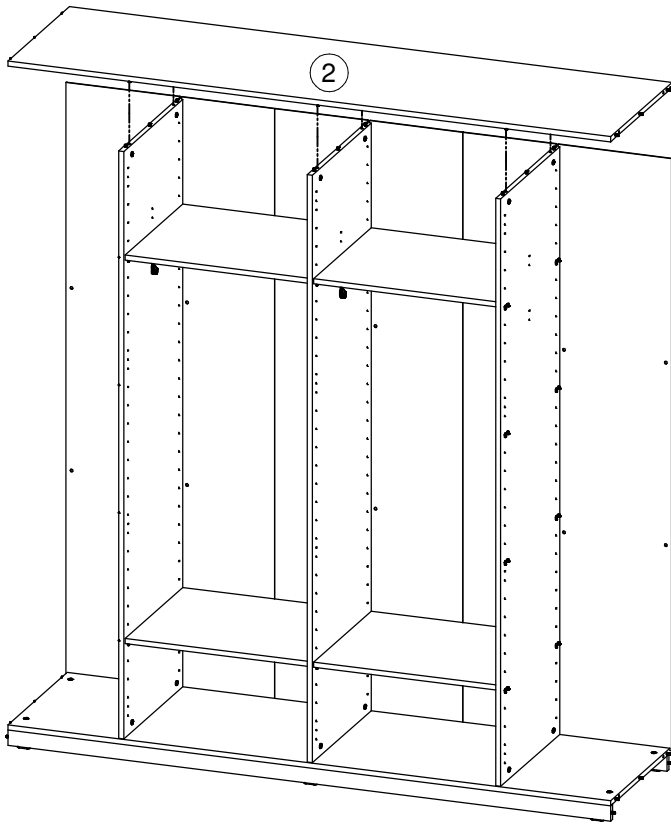
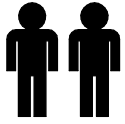

20

De resterende onderdelen uit de beslagzak worden gebruikt in handleiding 2 van het aangekochte meubel.

Les autres pièces de sachet de quincaillerie sont utilisées dans le manuel 2 du meuble acheté.

The remaining parts of the packet with fittings are used in manual 2 of the purchased furniture.

AAC

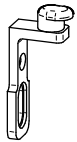

16x

AAD



16x

B

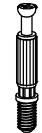

8x

BAG

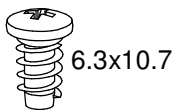

16x

I



3.5x16

38x



Deel 2

Partie 2

Part 2



Phaedra

2D Schuifdeur
2P Portes coulissantes
2D Sliding doors

Alc



Opbouw met 2 personen
Montage par 2 personnes
Assembling by 2 persons

Gebruik deze handleiding van begin tot einde voor het probleemloos monteren van uw aangekocht meubel aub.

Veuillez bien suivre nos instructions ci-après lors du montage de votre meuble. Merci.

Please use the manual from the beginning until the end to assemble your newly bought furniture without troubles.

Handleiding 2

Manuel 2

Manual 2

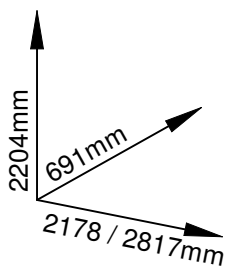
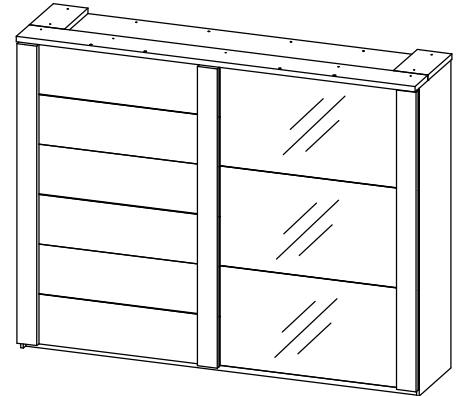

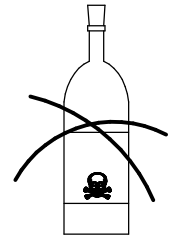
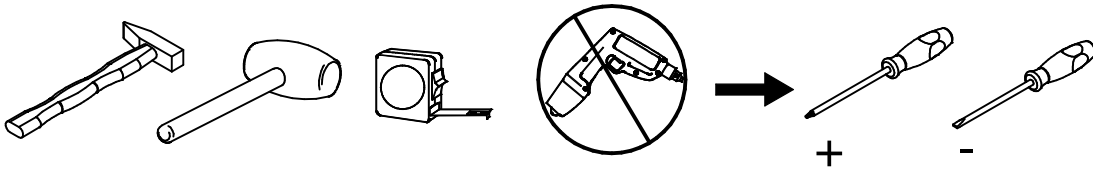

SOLVANT
DILUANT
OPLOSMIDDEL
THINNER

(FR) Entretien: utilisez un chiffon légèrement humide et séchez aussitôt. Toute trace de liquide doit être enlevé immédiatement. Meuble inadapté aux pièces humides. N' utilisez jamais du solvant, détergent, diluant, produits chimiques ou cirage. Notice du montage à conserver. Pour tous service apres-vente, rendezvous au magasin avec cette notice.

(GB) Maintenance: clean with slightly wet moistened cloth, wipe dry immediately. Wipe off wetness at once. Not suited for humid locations. Never use solvent, cleaner, thinner, chemical products or wax. Retain manual instruction. For the after sales, go back to the shop with this assembly instruction.

(NL) Onderhoud: met licht vochtige doek reinigen hierna direct droog wrijven. Vocht op het bovenblad direct opnemen. De meubels zijn niet voor vochtige ruimten bestemd. Gebruik nooit oplosmiddel, reinigingsmiddel, verdunner, chemische producten of boenwas. Montage tekening opbergen. Voor service na verkoop, ga naar uw leverancier met deze montage handleiding.

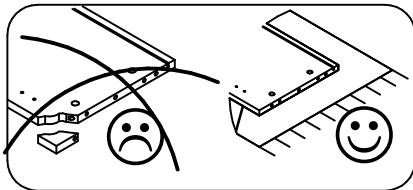

Made in Belgium

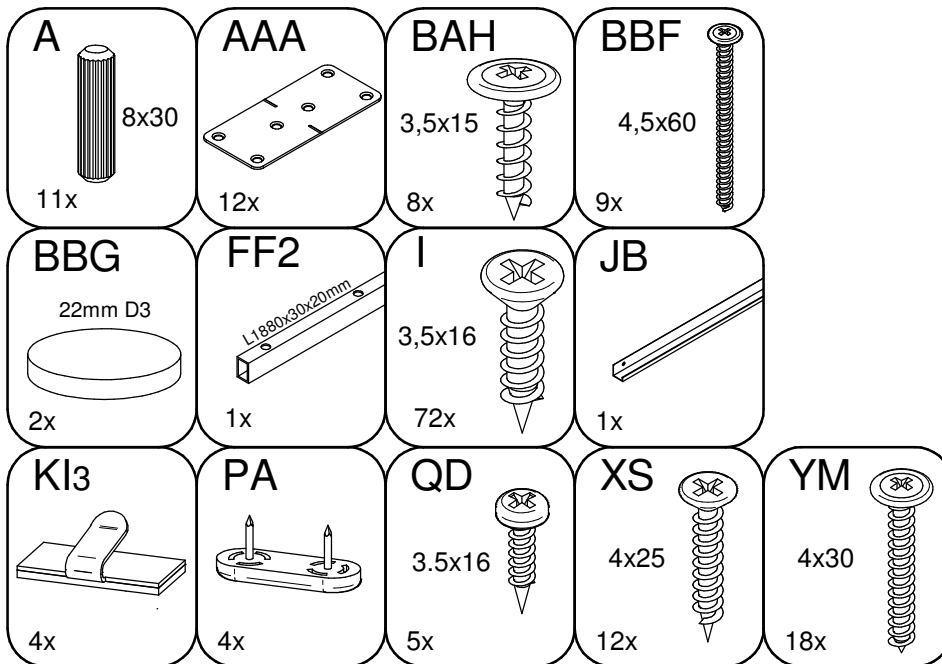
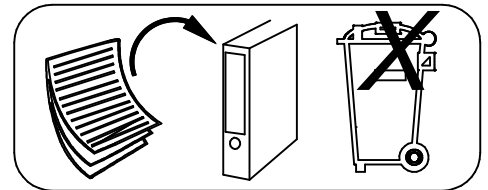

In doos verlichting
Dans la boîte d'éclairage
In box with lights

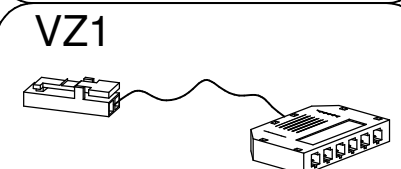
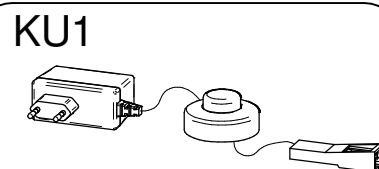
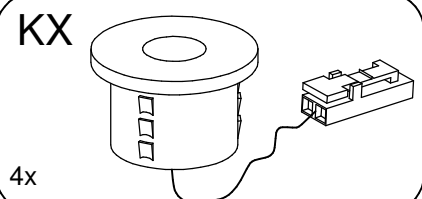

Gelieve eerst handleiding 1 te doorlopen a.u.b.
Le premier, suivre le manuel 1 s.v.p.
Please follow manual 1 first before continuing this one.

De resterende onderdelen uit handleiding 1 van het aangekochte meubel:

Les autres pièces du manuel 1 du meuble acheté:

The remaining parts from manual 1 of the purchased furniture:

Beslagzak / sachet de quincaillerie / packet with fittings

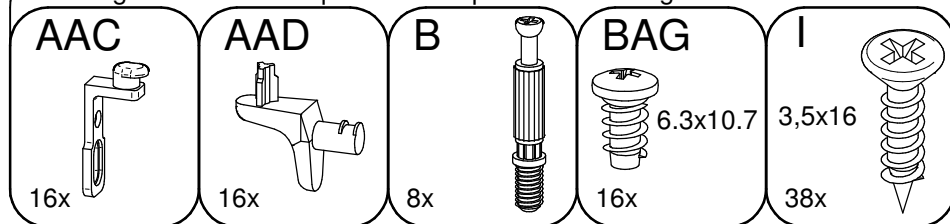

Doos 1 / boîte 1 / box 1

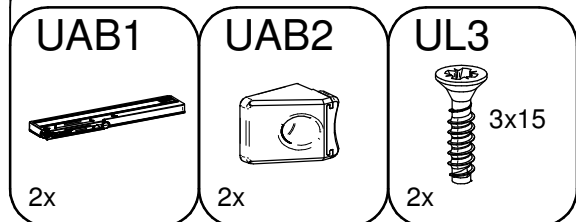

Doos 2 / boîte 2 / box 2

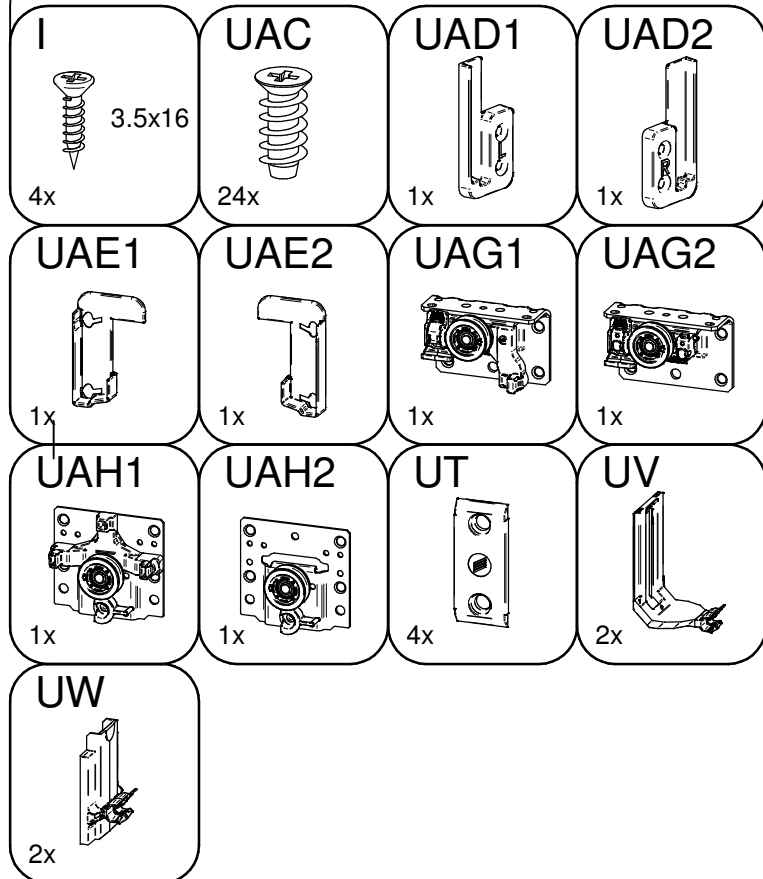

Afhankelijk van de kastbreedte:

Dépendant de largeur de l'armoire:

Depends on the width of the cabinet:

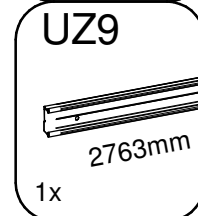
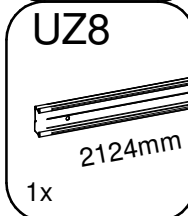
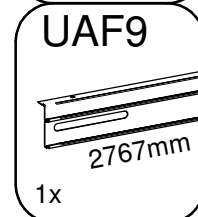
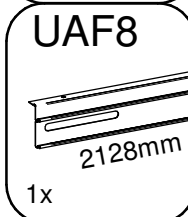
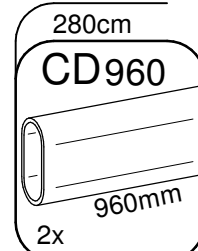
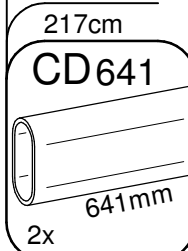

21

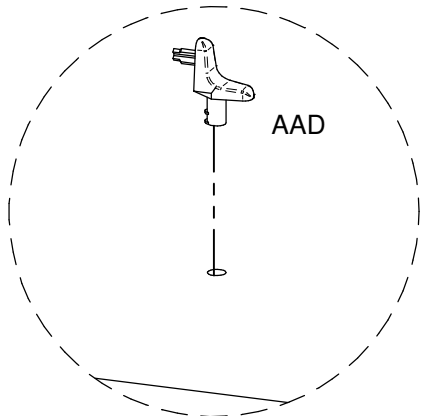
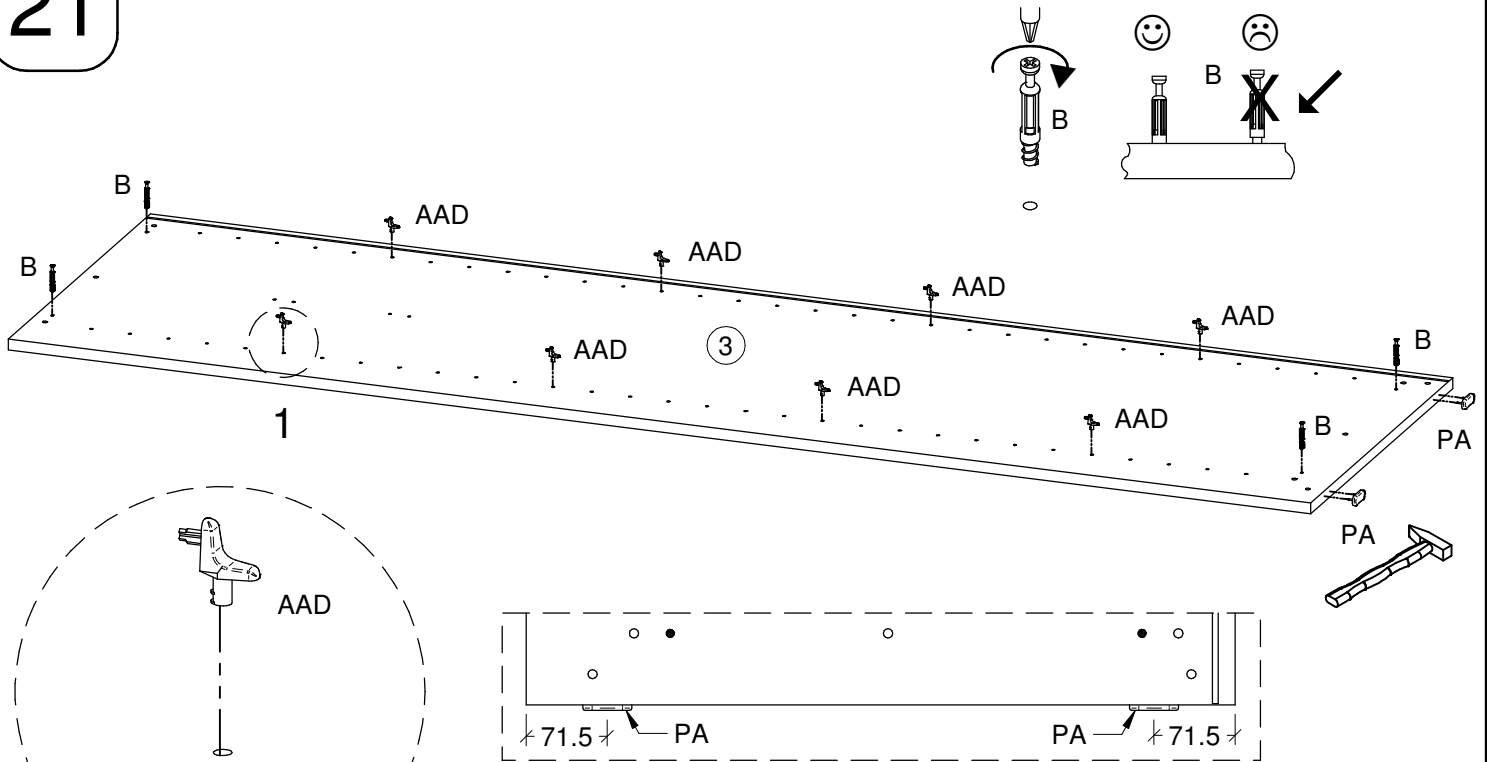

DETAIL 1

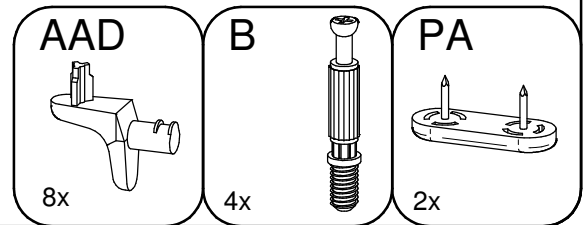

22

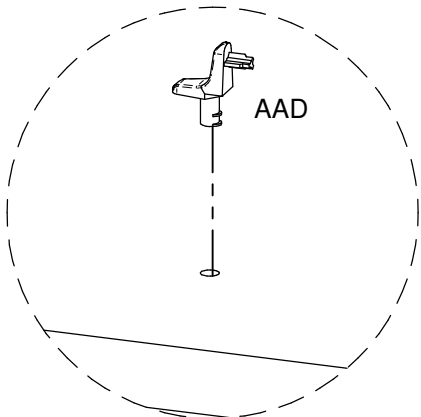
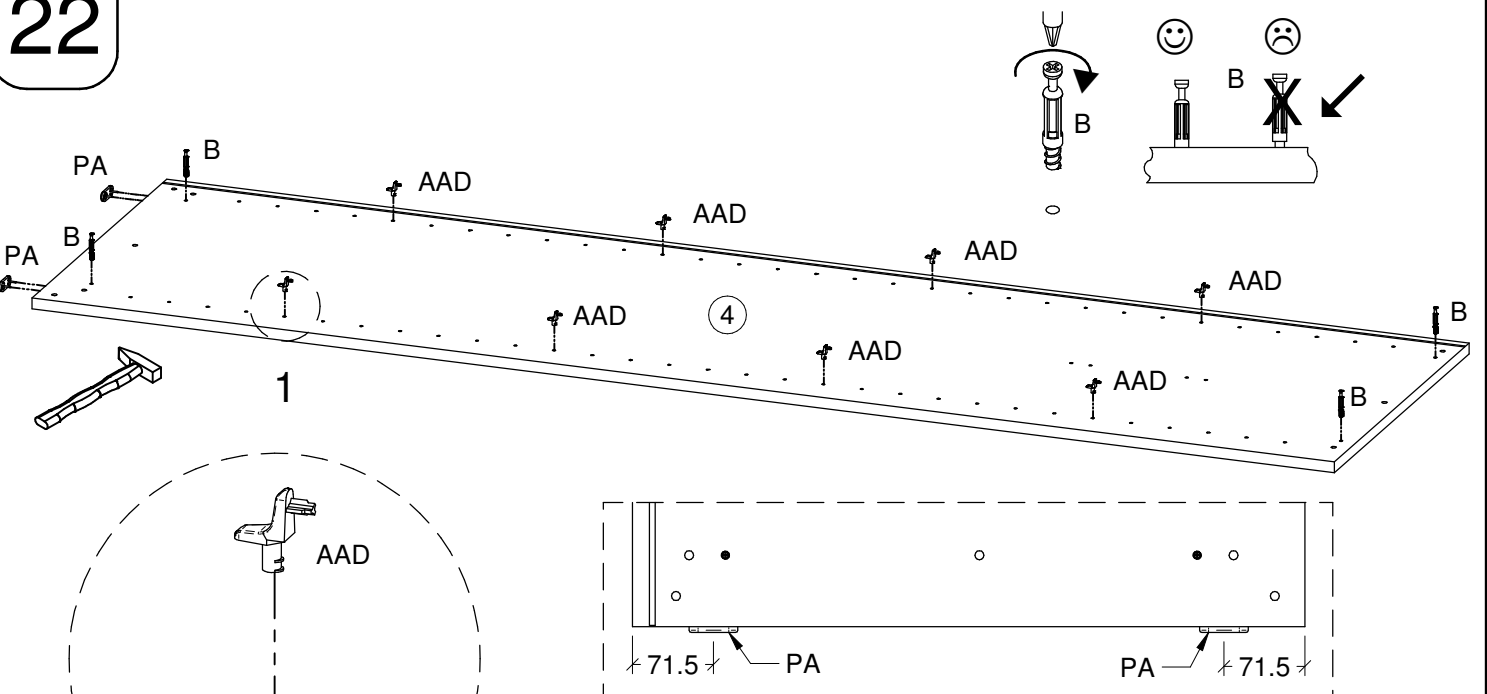

DETAIL 1

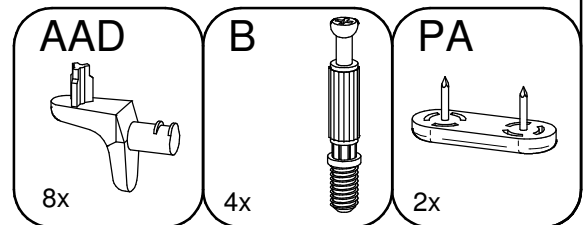

23

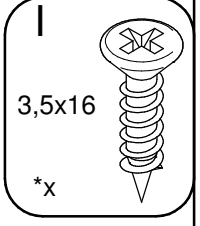
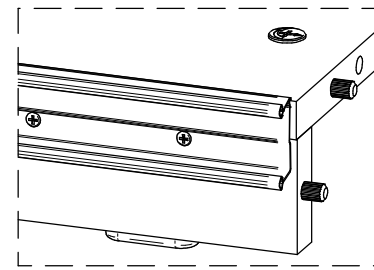
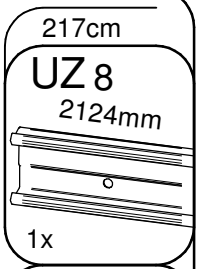
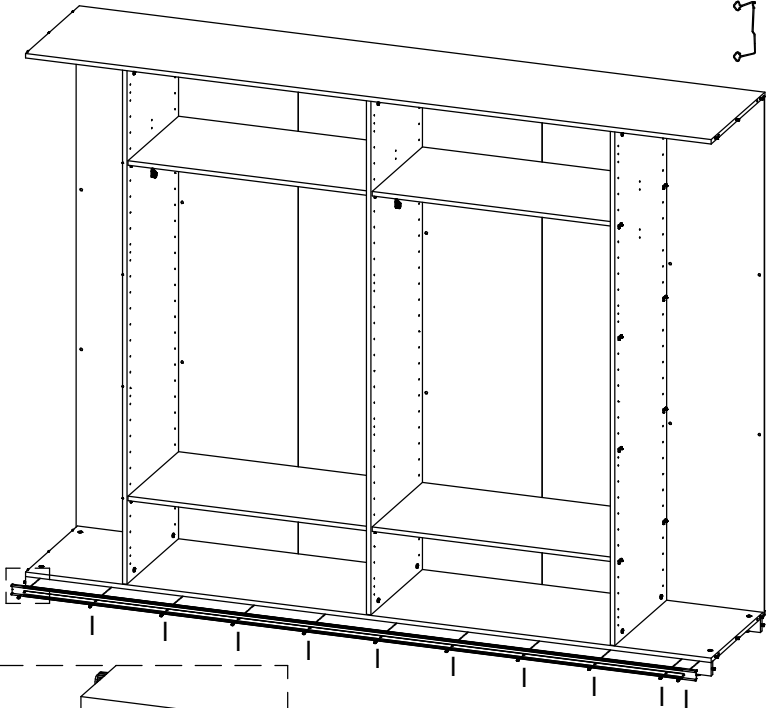

Of / ou / or

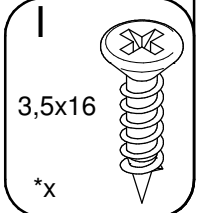
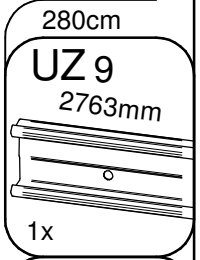

*Het aantal schroeven is afhankelijk van de kastbreedte
 *Le nombre de vis dépend de la largeur de l'armoire
 *The number of screws depends on the width of the cabinet

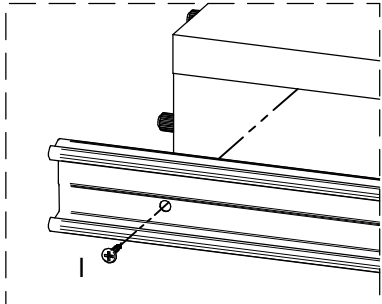

DETAIL 1

24

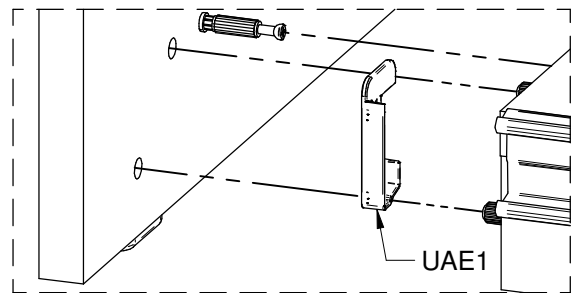
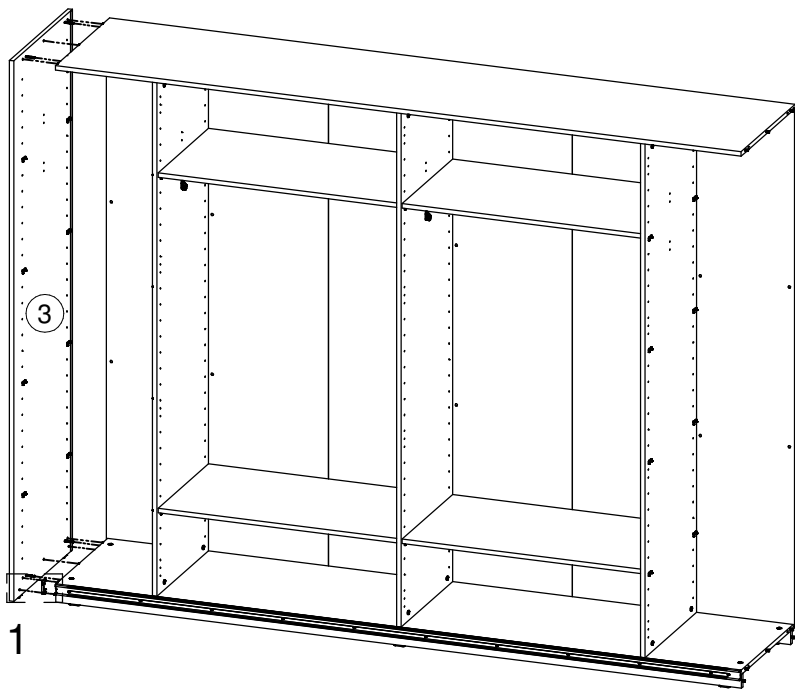

DETAIL 1

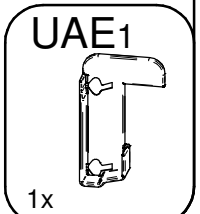
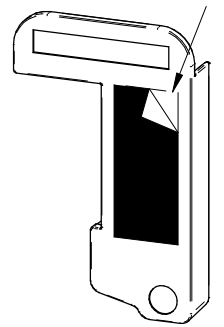
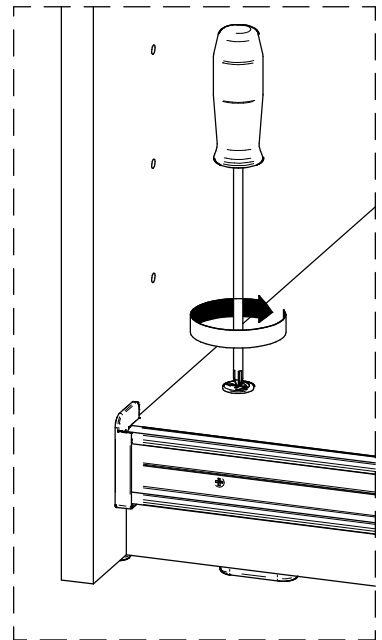

25

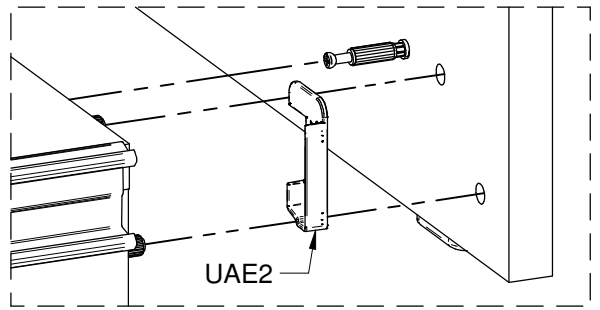
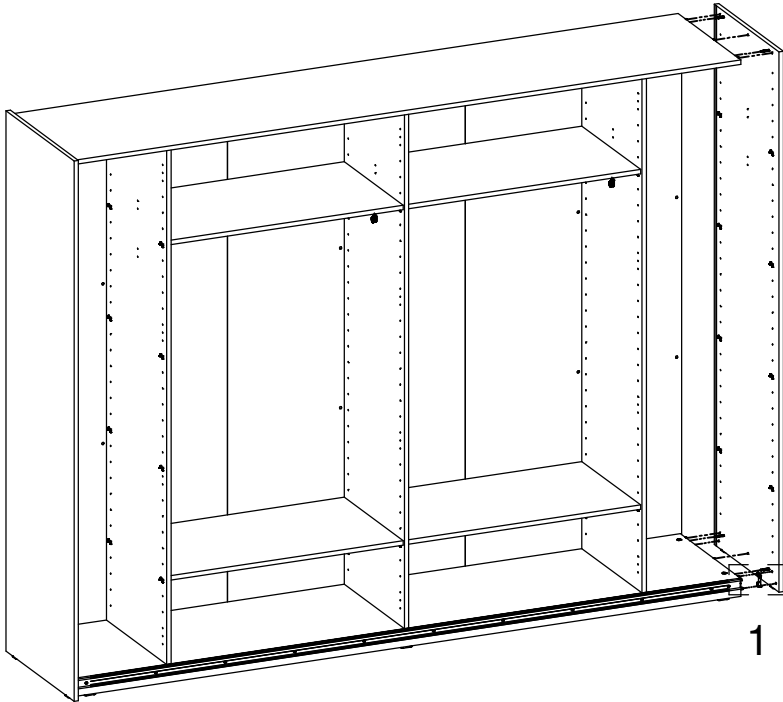

DETAIL 1

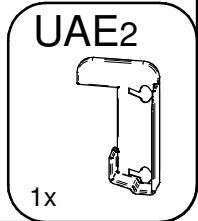
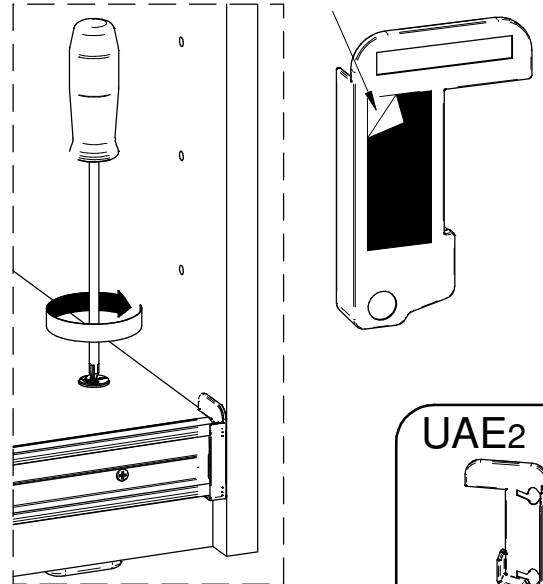

26

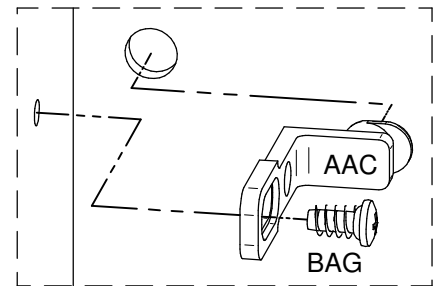
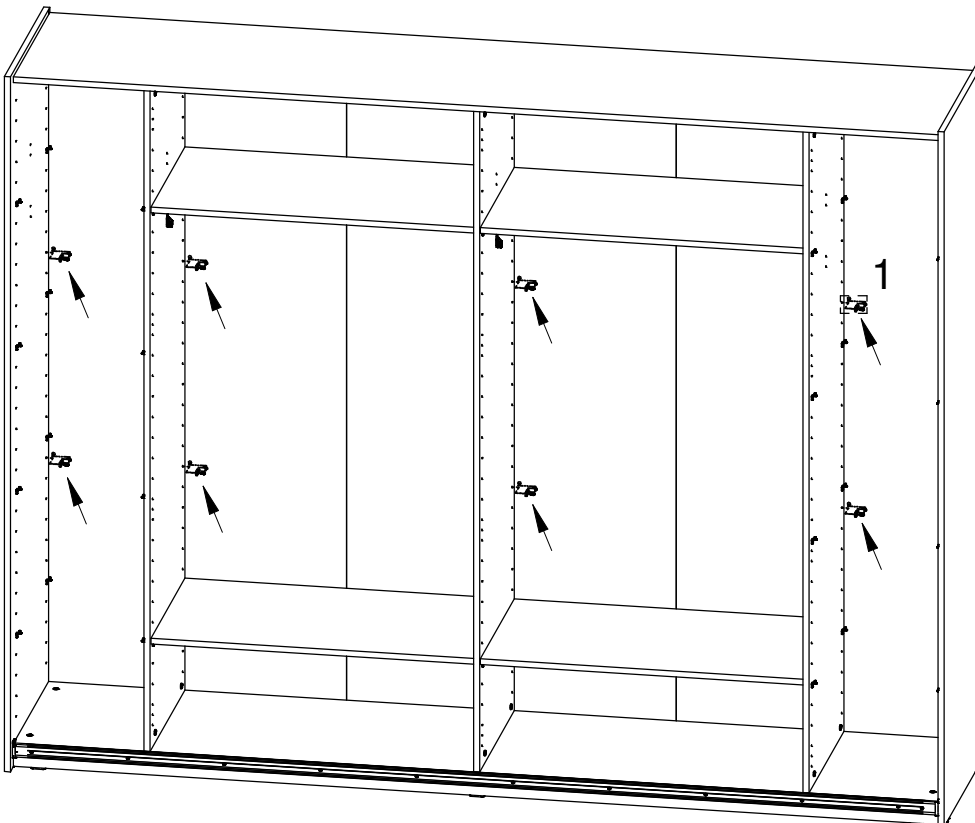

DETAIL 1

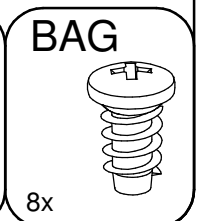
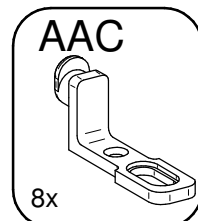

27

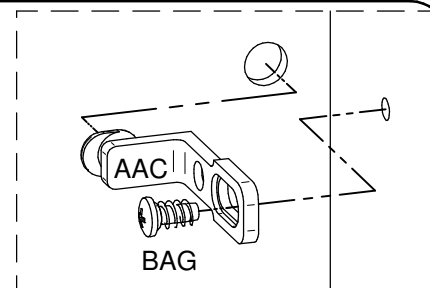
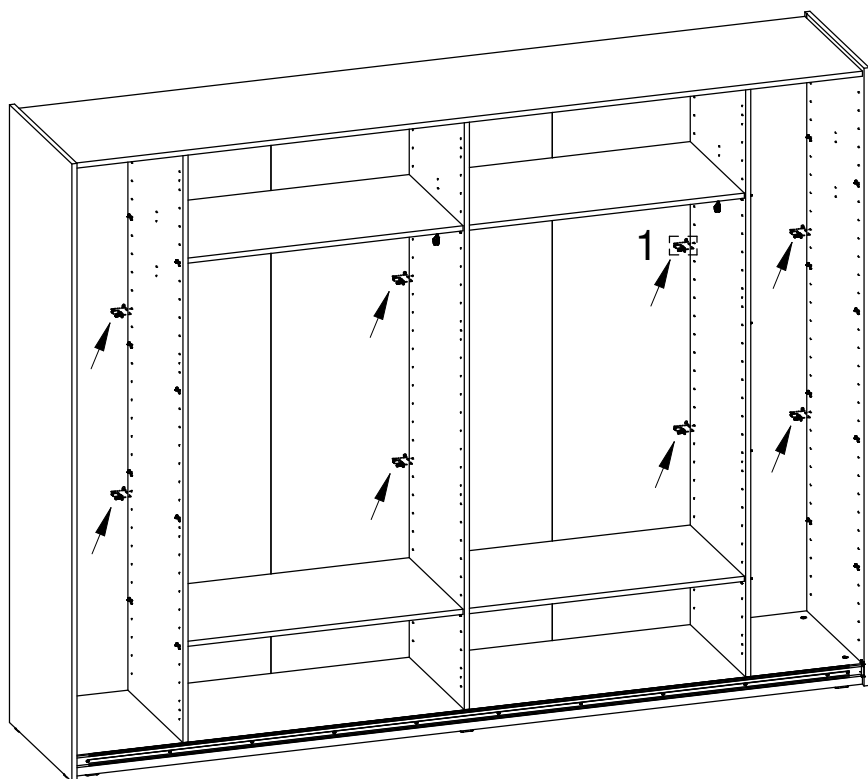

DETAIL 1

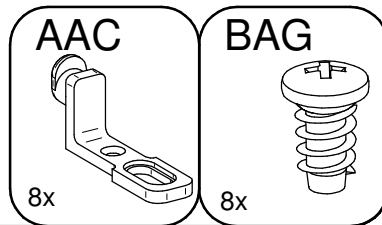

28

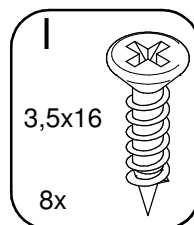
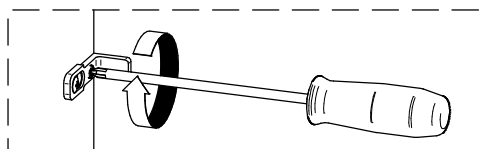
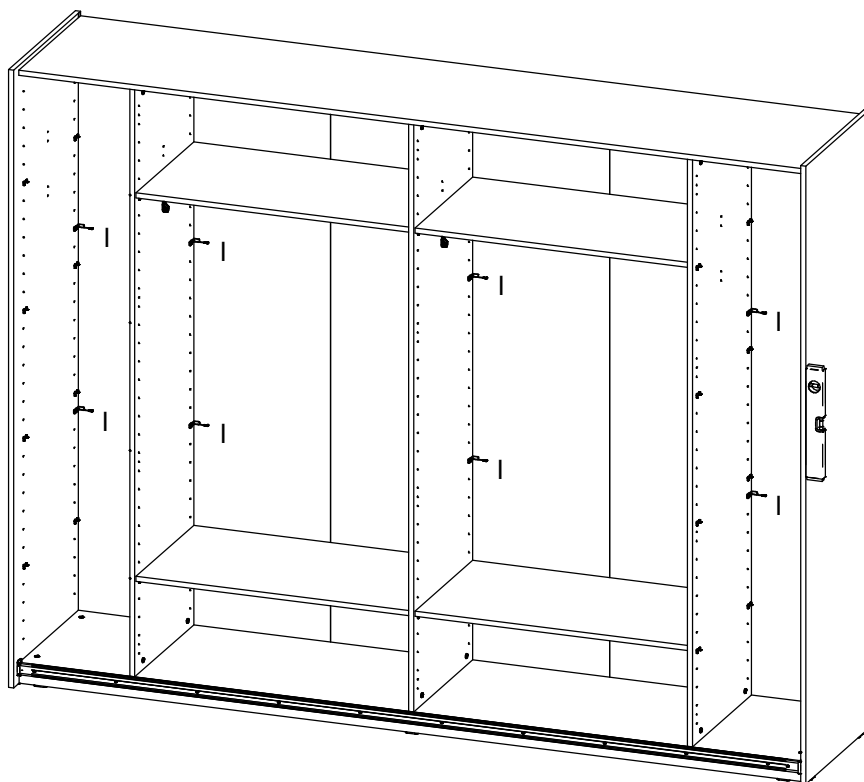

29

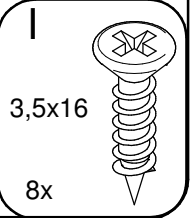
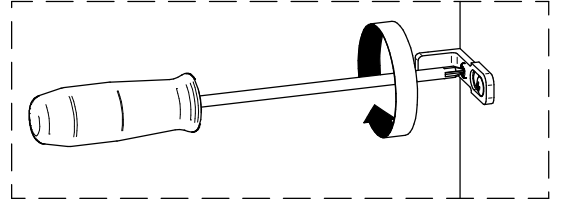
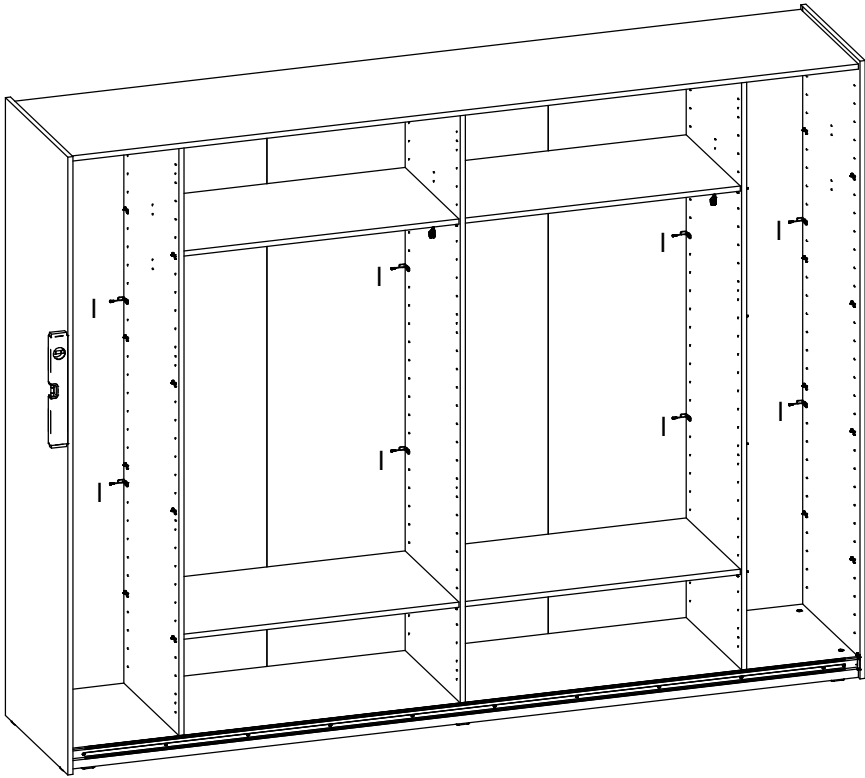

30

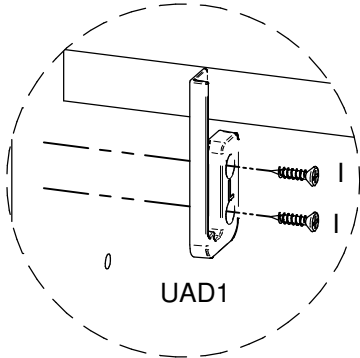
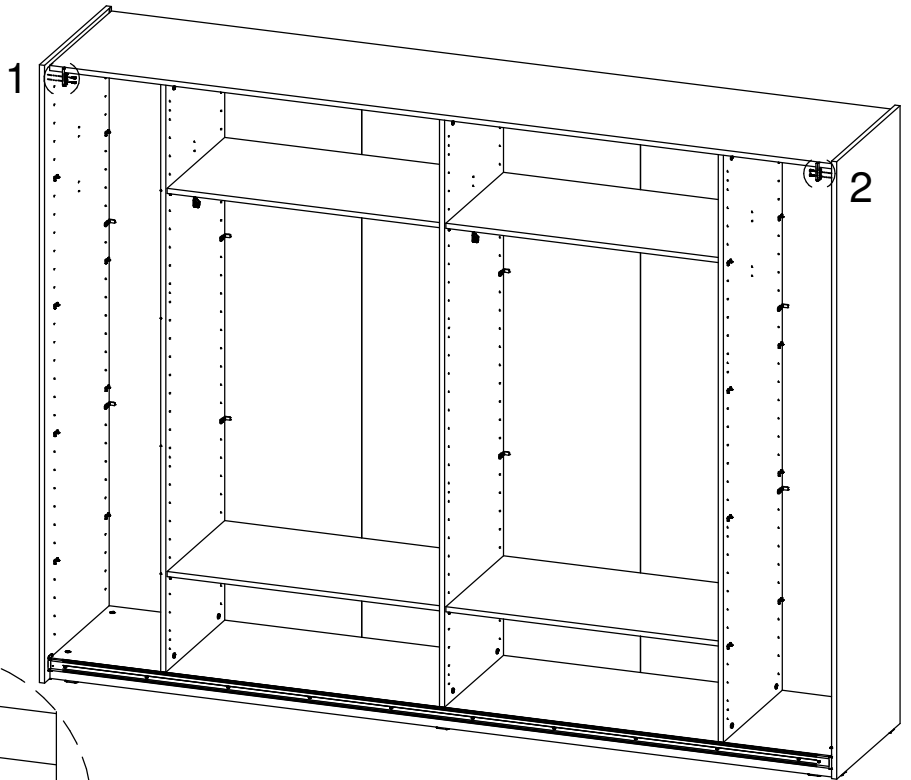

DETAIL 1

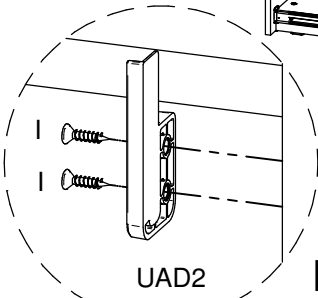
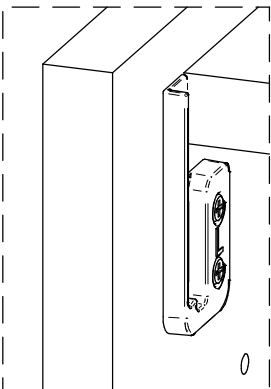

DETAIL 2

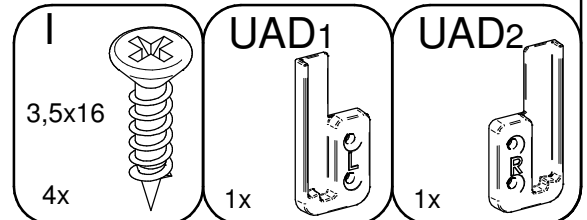

31

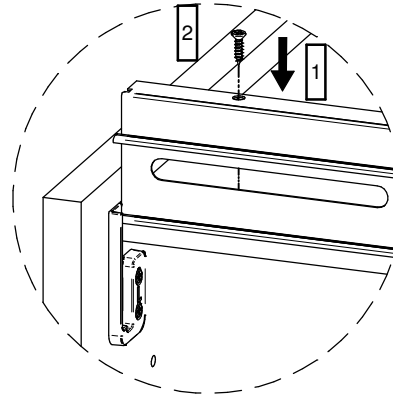
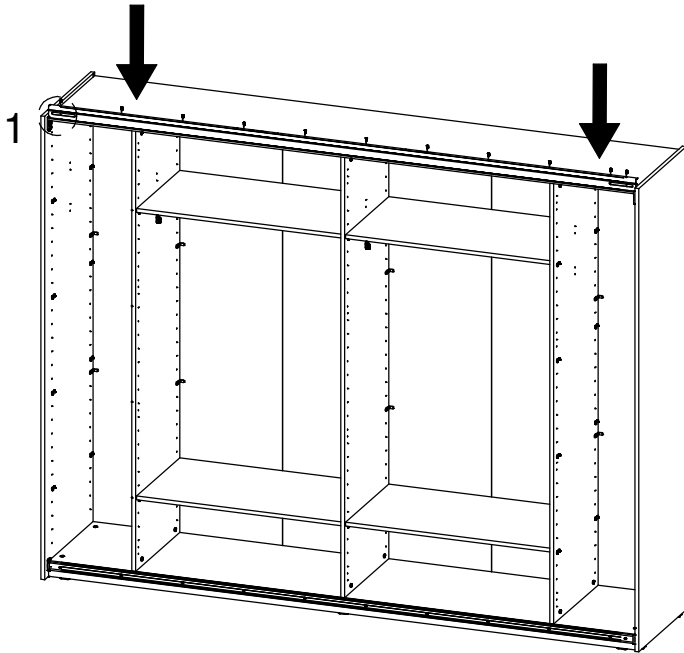

DETAIL 1

*Het aantal schroeven is afhankelijk van de kastbreedte

*Le nombre de vis dépend de la largeur de l'armoire

*The number of screws depends on the width of the cabinet

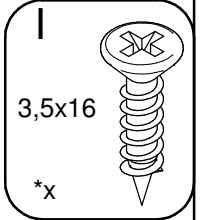
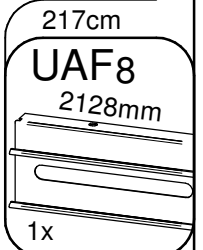

Of / ou / or

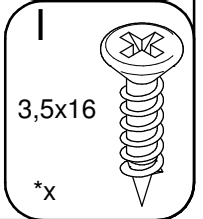
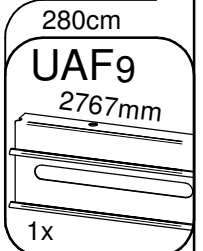

32

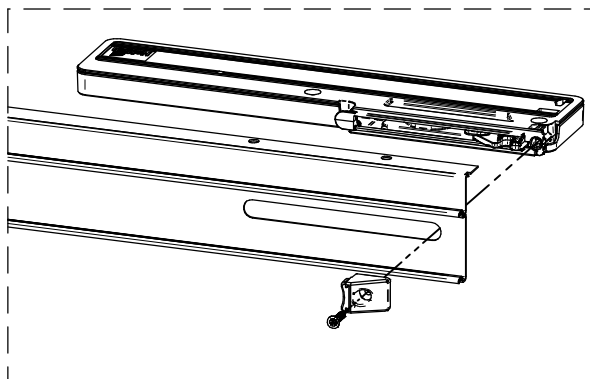
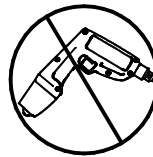
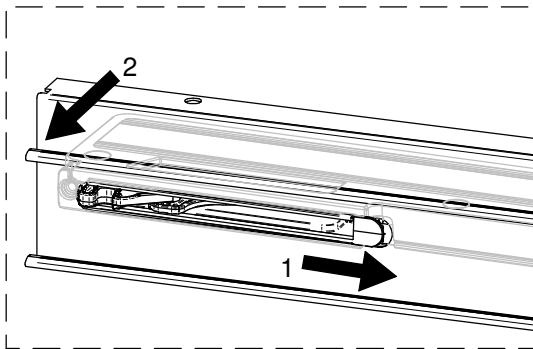
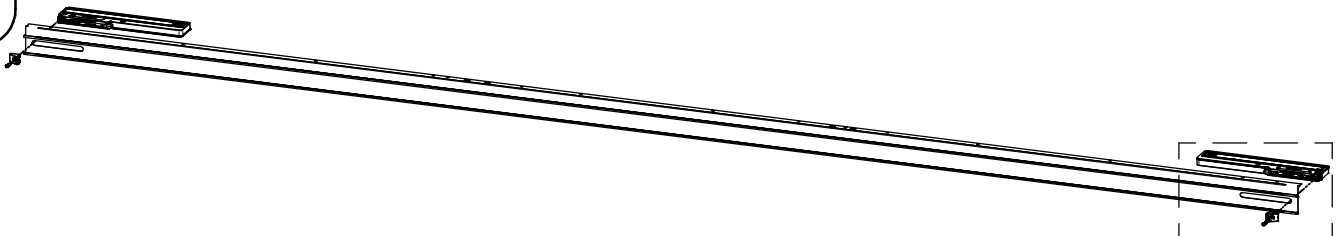

DETAIL 1

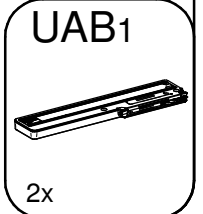
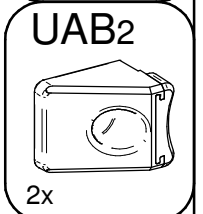
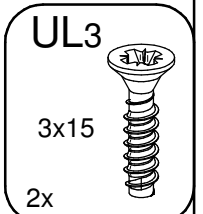

33

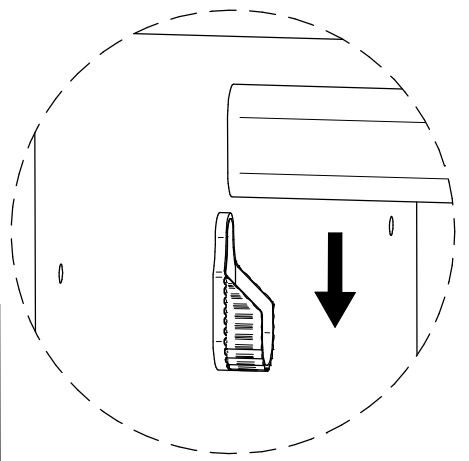
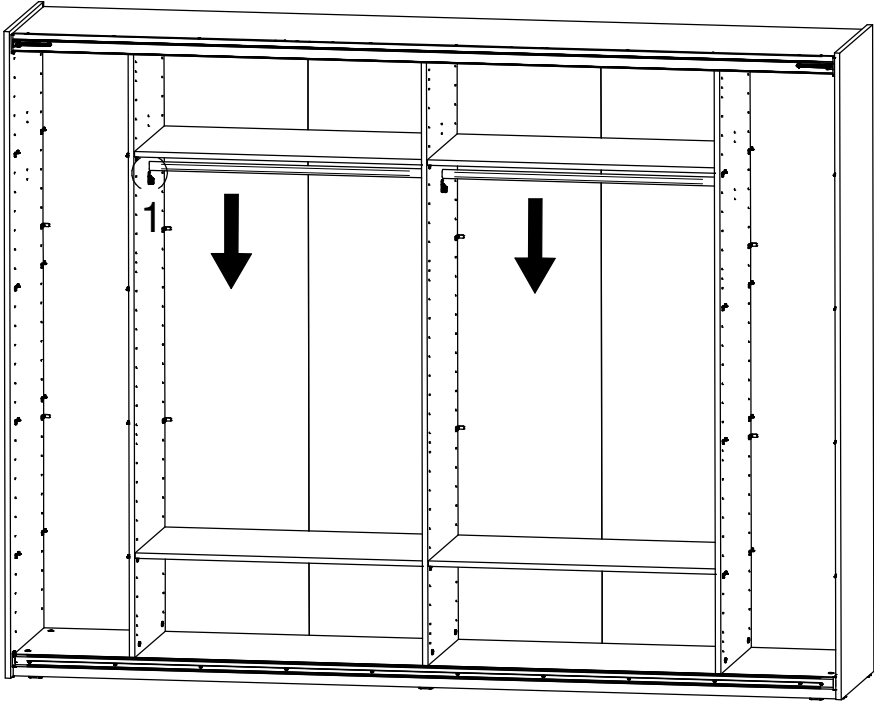

DETAIL 1

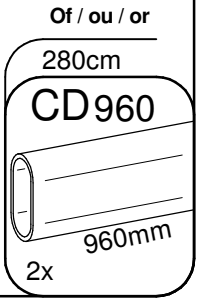
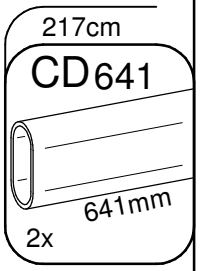

34

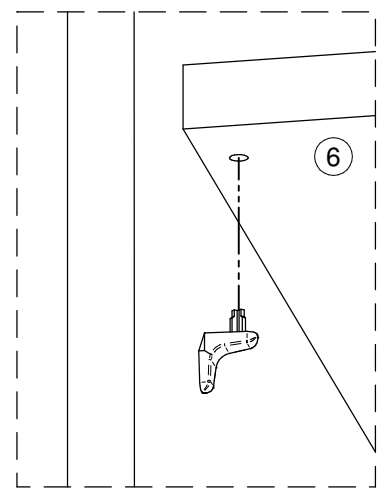
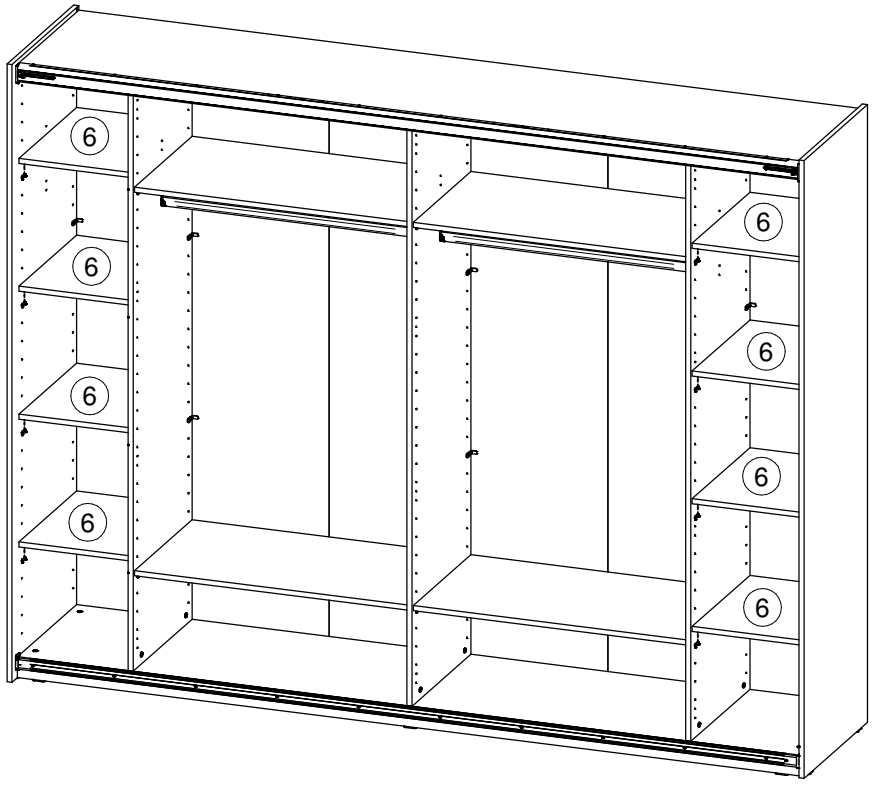

35

3x

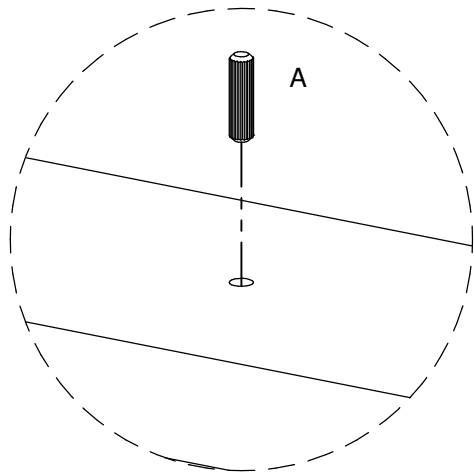
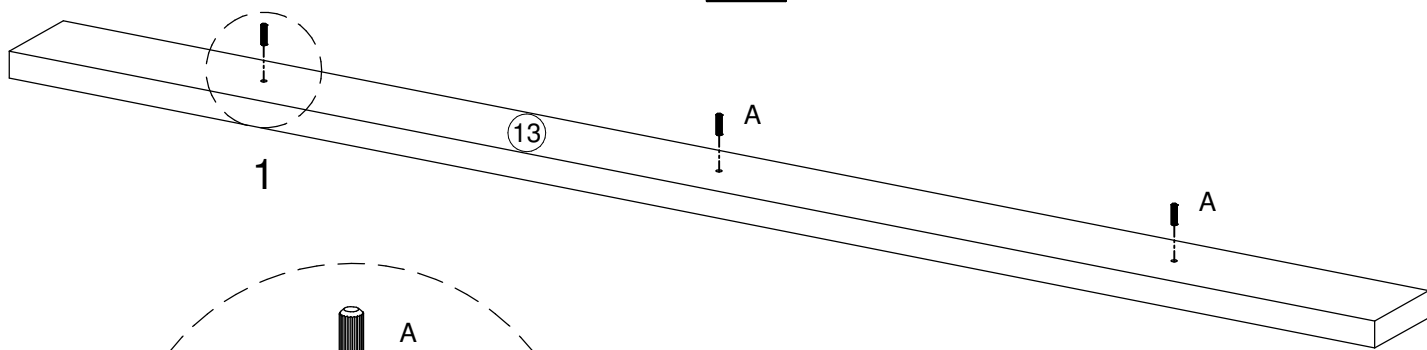

DETAIL 1

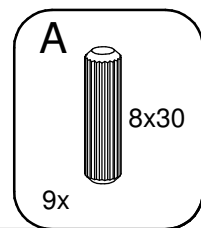

36

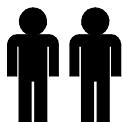

Linkse deur
Porte gauche
Left door

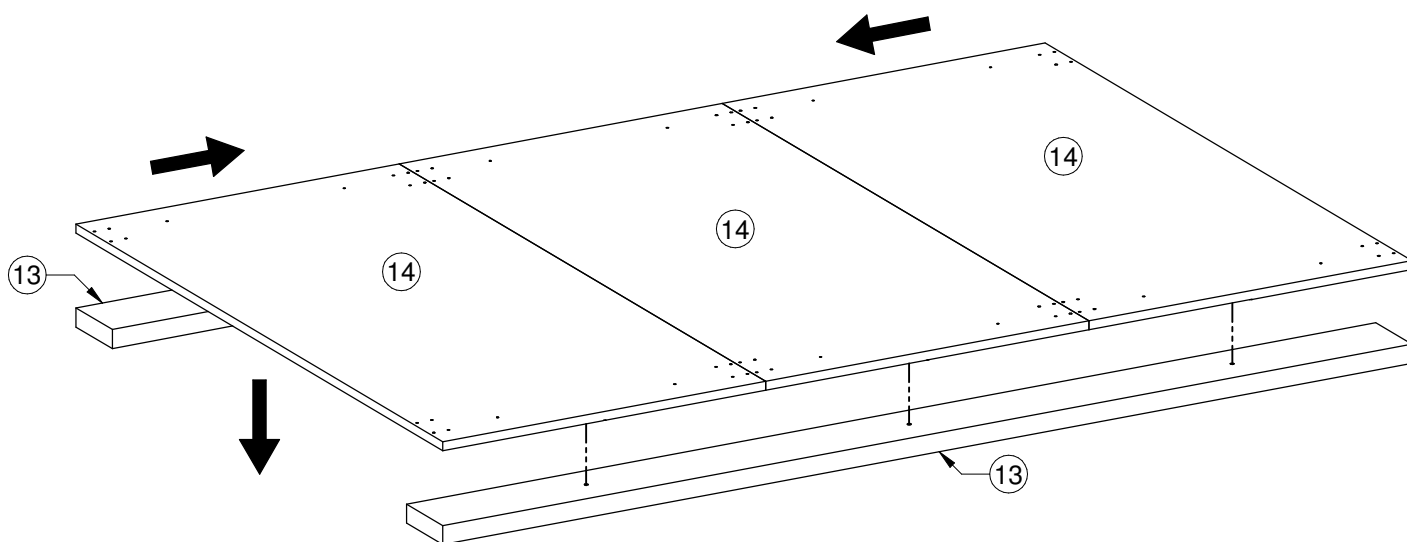

37

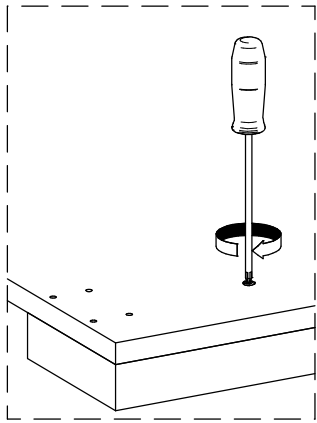
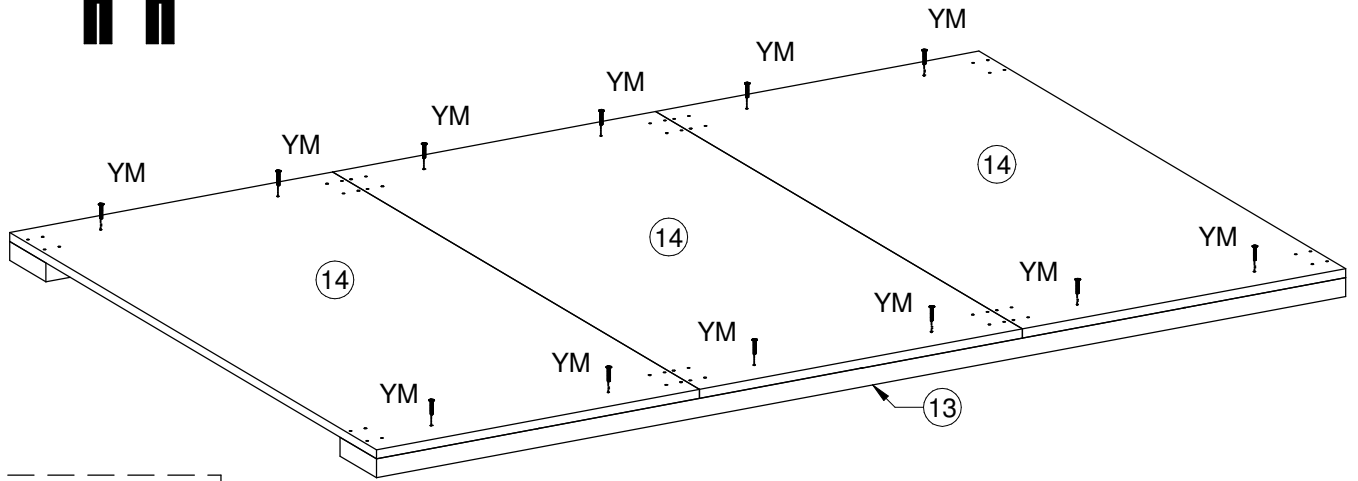

Linkse deur
Porte gauche
Left door

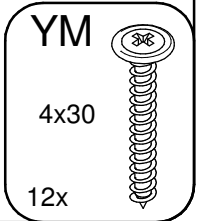

38

Linkse deur
Porte gauche
Left door

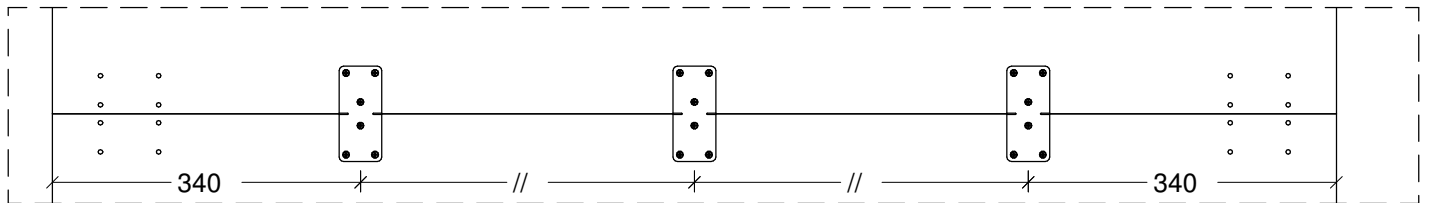
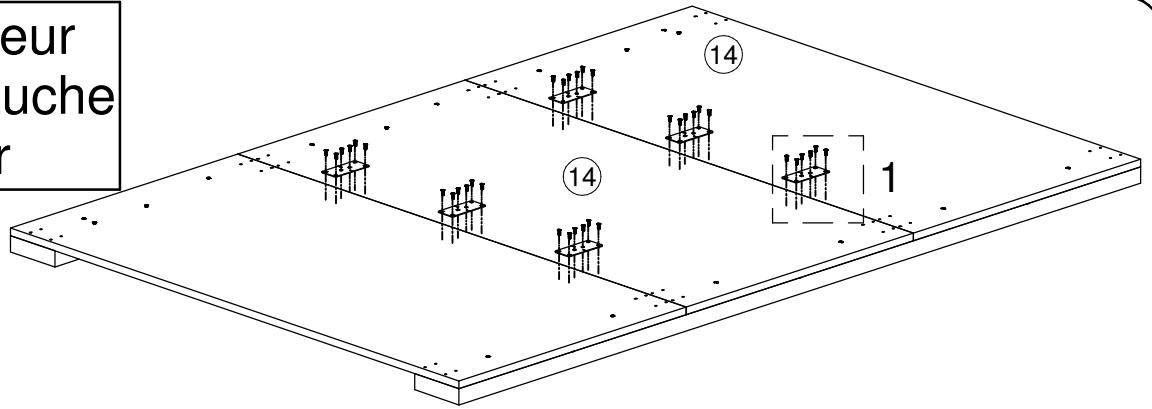

DETAIL 1

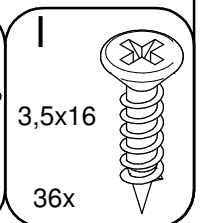
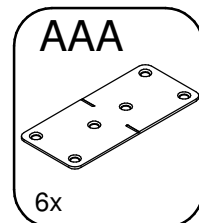
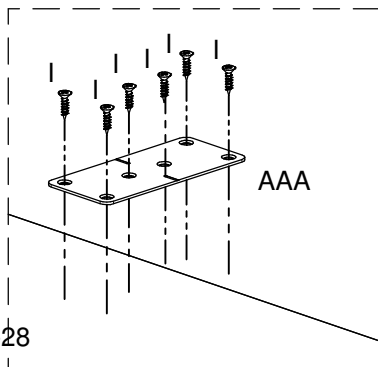

39

Linkse deur
Porte gauche
Left door

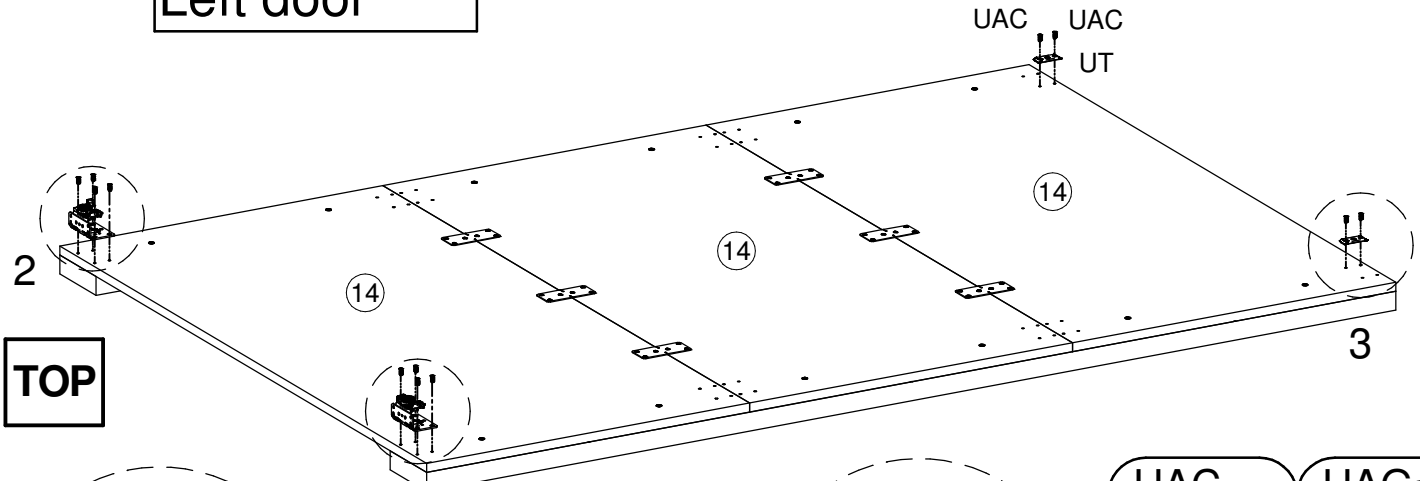

TOP

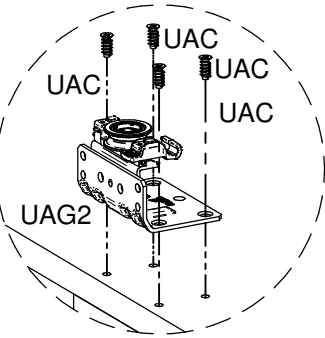

DETAIL 1

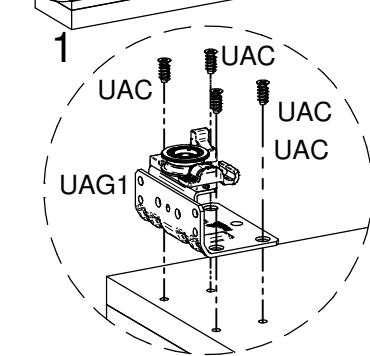

DETAIL 2

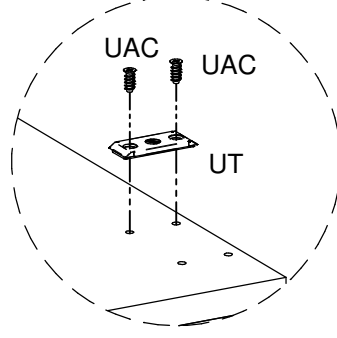

DETAIL 3

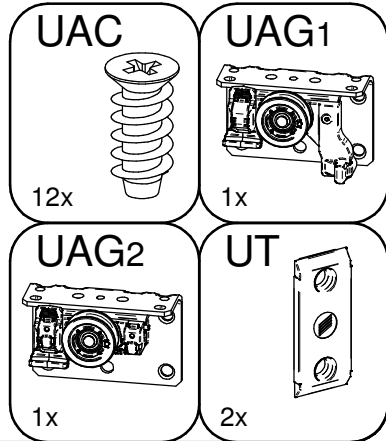

40

Linkse deur
Porte gauche
Left door

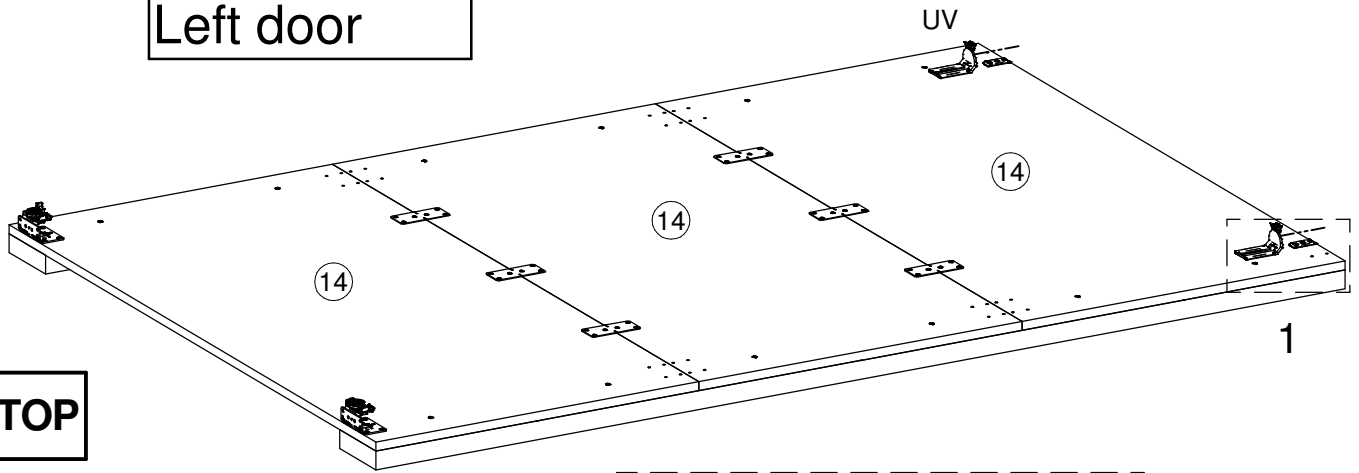

TOP

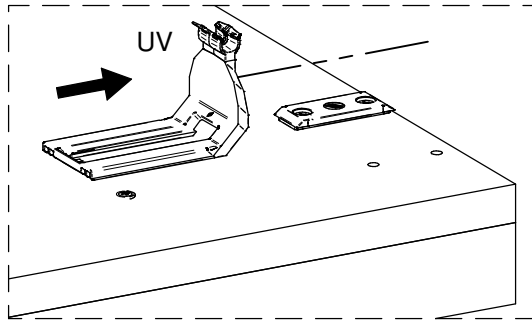

DETAIL 1

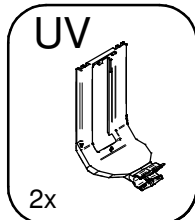

41

Linkse deur
Porte gauche
Left door

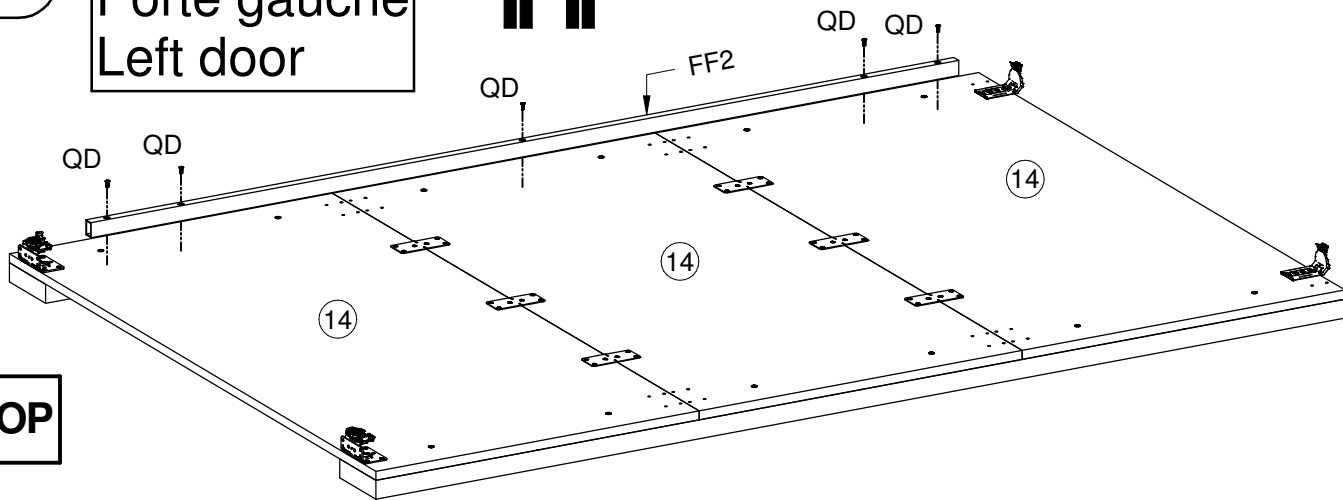

TOP

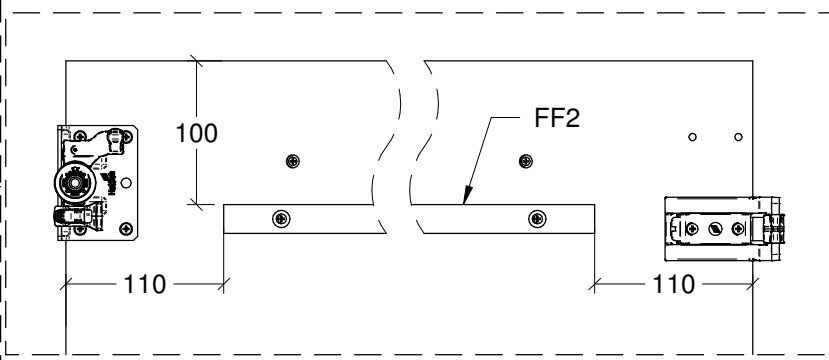
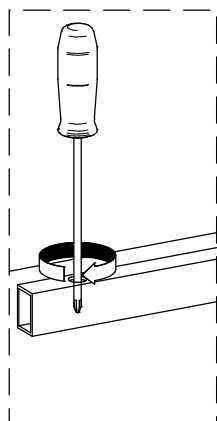

FF2	QD
L 1880x30x20mm	3.5x16
1x	5x

42

Linkse deur
Porte gauche
Left door

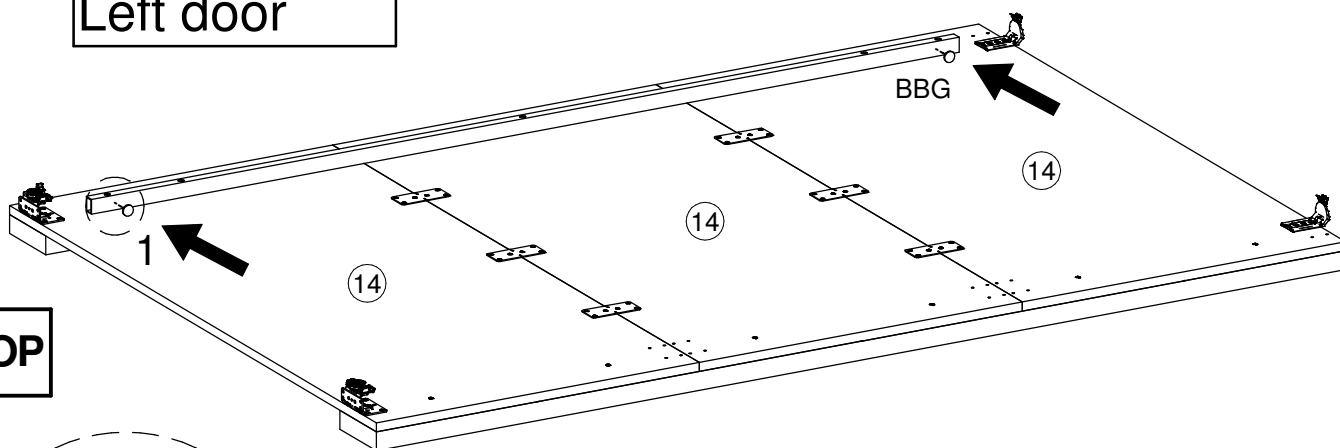

TOP

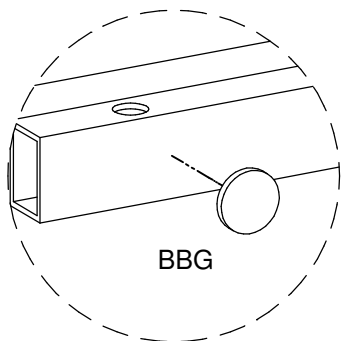

BBG

DETAIL 1

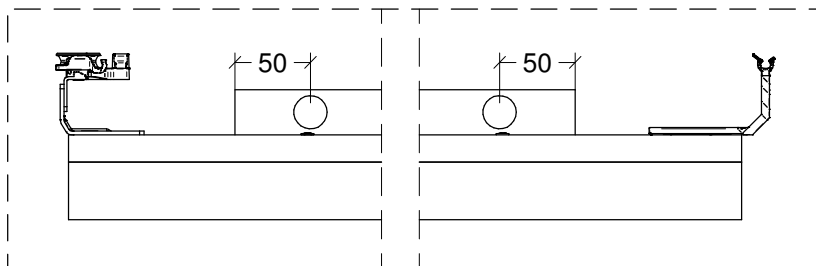

BBG

22mm D3



2x

43

- Neem de deur vast met twee personen en plaats deze tegen de muur.
- Saisissez la porte à deux personnes et placez-la contre le mur.
- Take the door with two persons and place it to the wall.

44

Rechtse deur
Porte droite
Right door

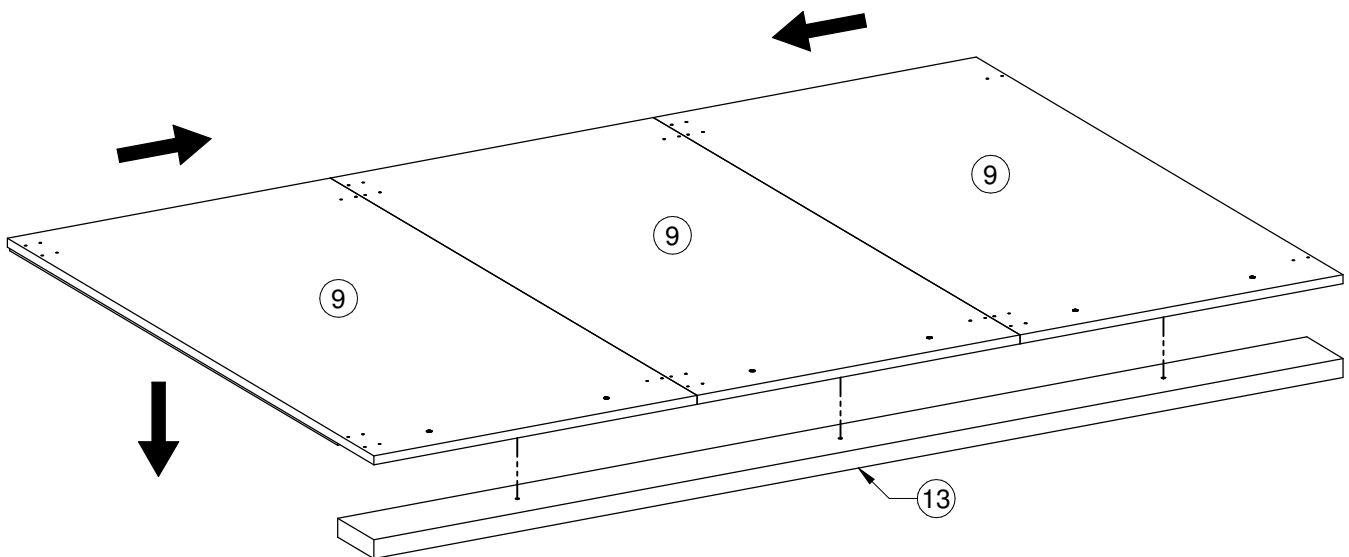
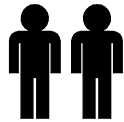

45

Rechtse deur
Porte droite
Right door

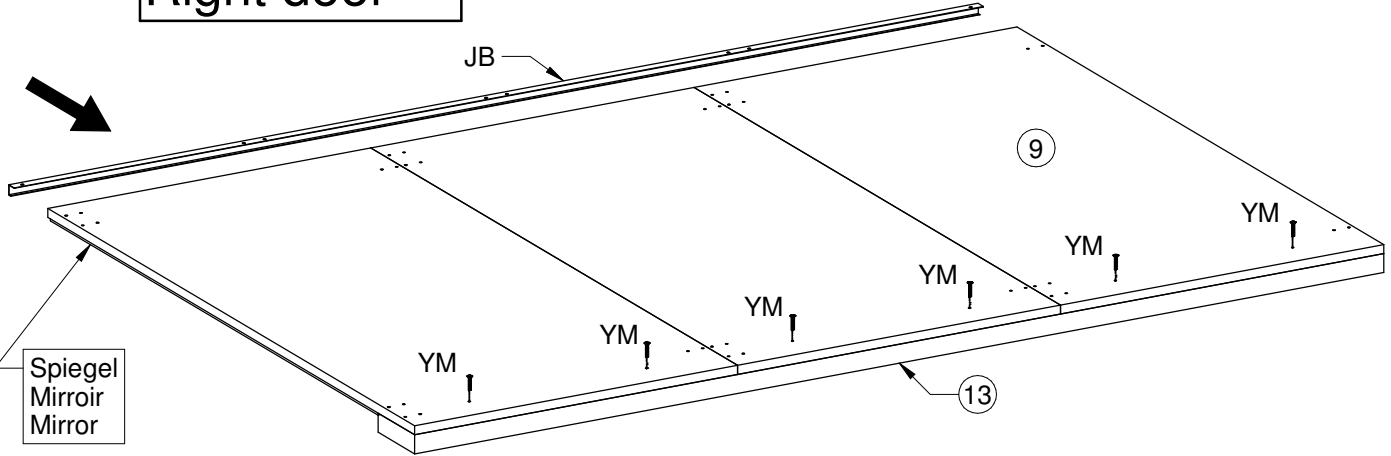

Spiegel
Miroir
Mirror

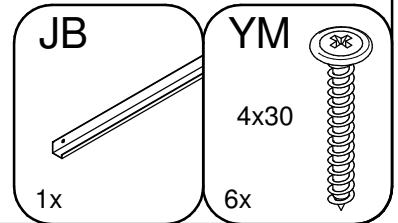
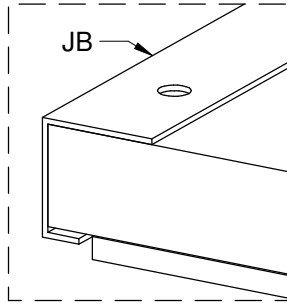
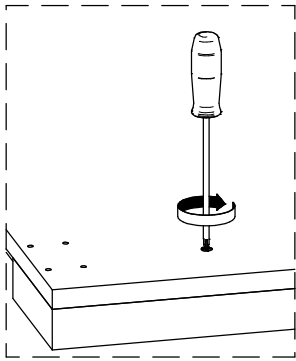

46

Rechtse deur
Porte droite
Right door

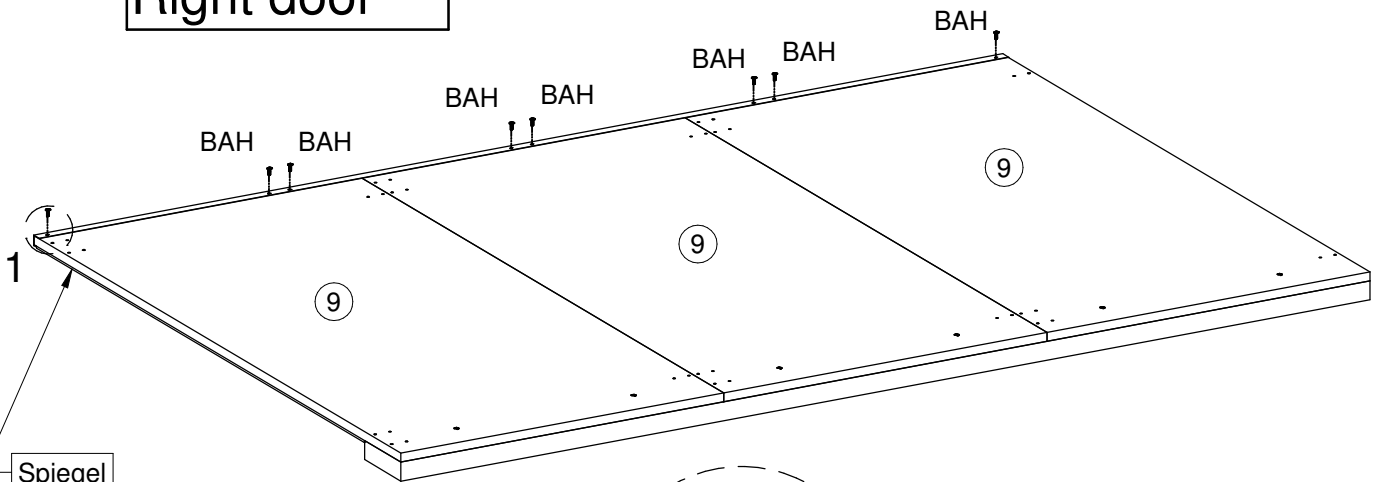
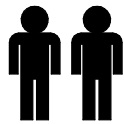

Spiegel
Miroir
Mirror

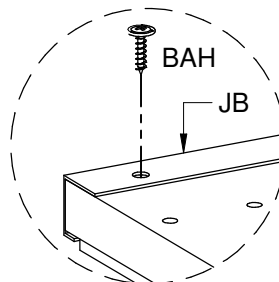

DETAIL 1

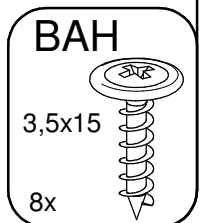

47

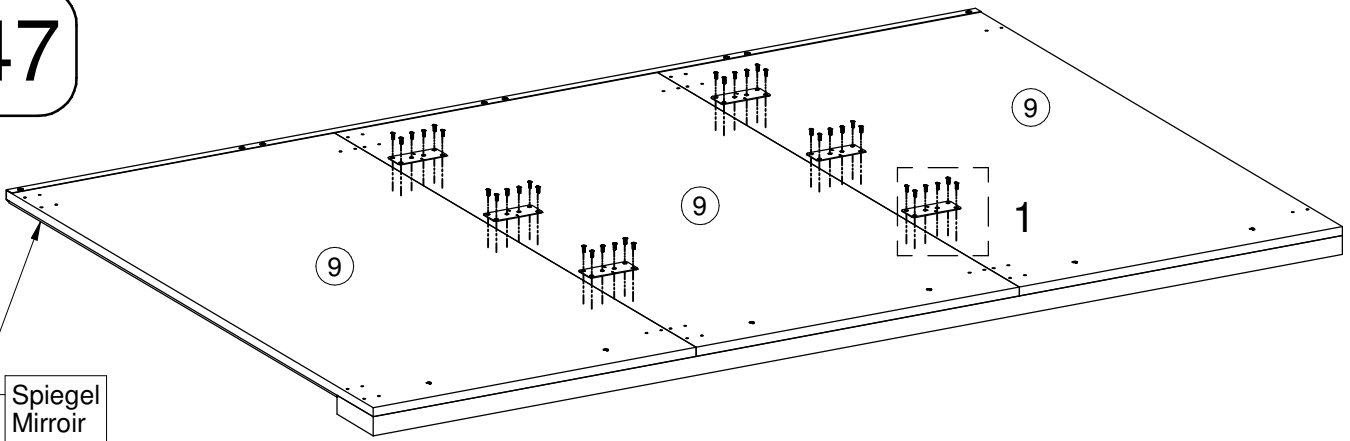

Spiegel
Mirroir
Mirror

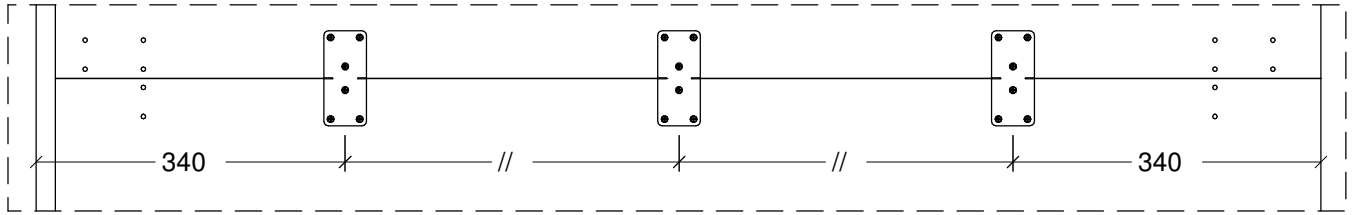

Rechtse deur
Porte droite
Right door

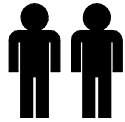

DETAIL 1

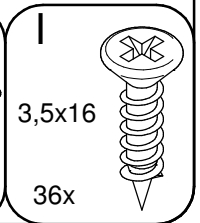
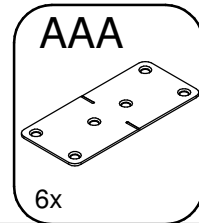
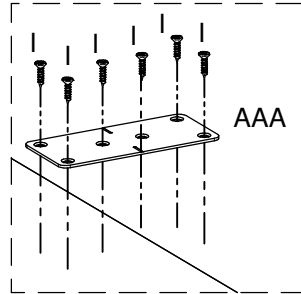

48

Rechtse deur
Porte droite
Right door

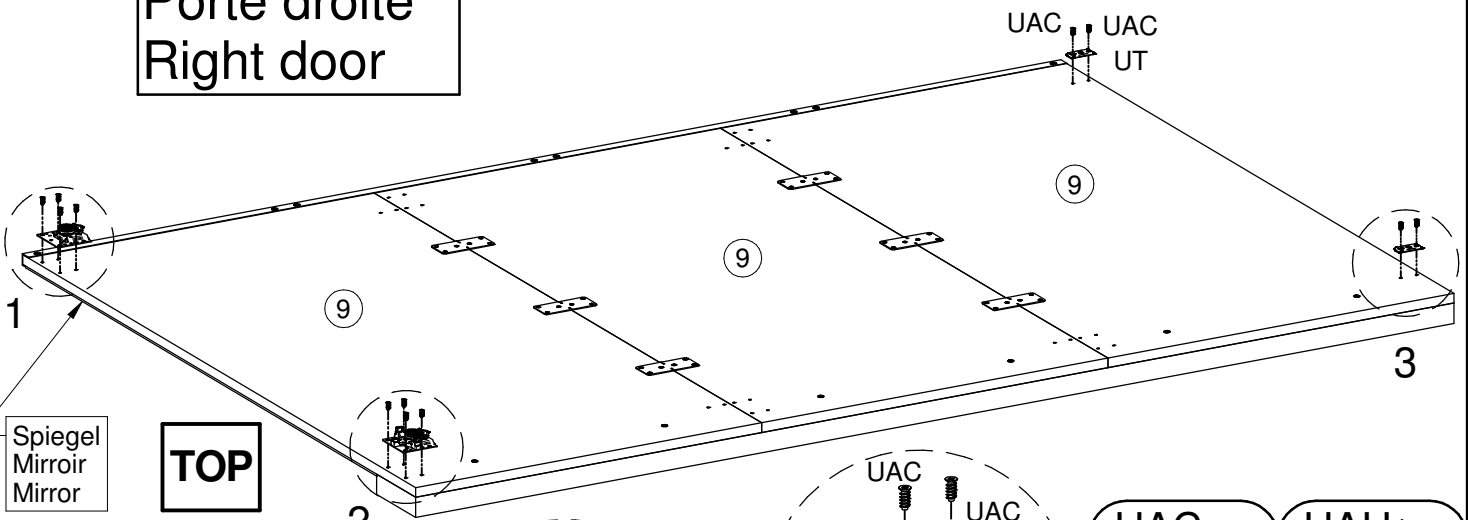

Spiegel
Mirroir
Mirror

TOP

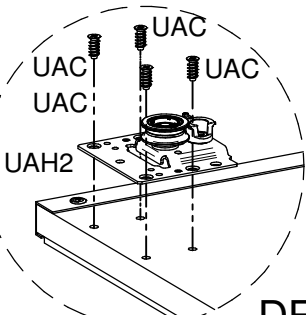

DETAIL 1

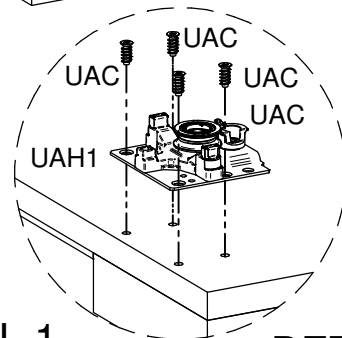

DETAIL 2

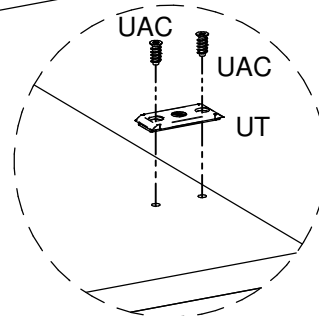

DETAIL 3

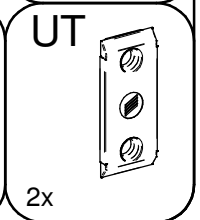
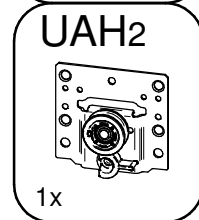
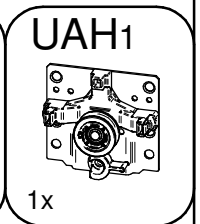
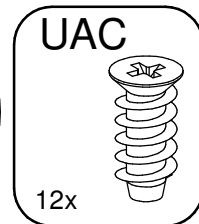

49

Rechtse deur
Porte droite
Right door

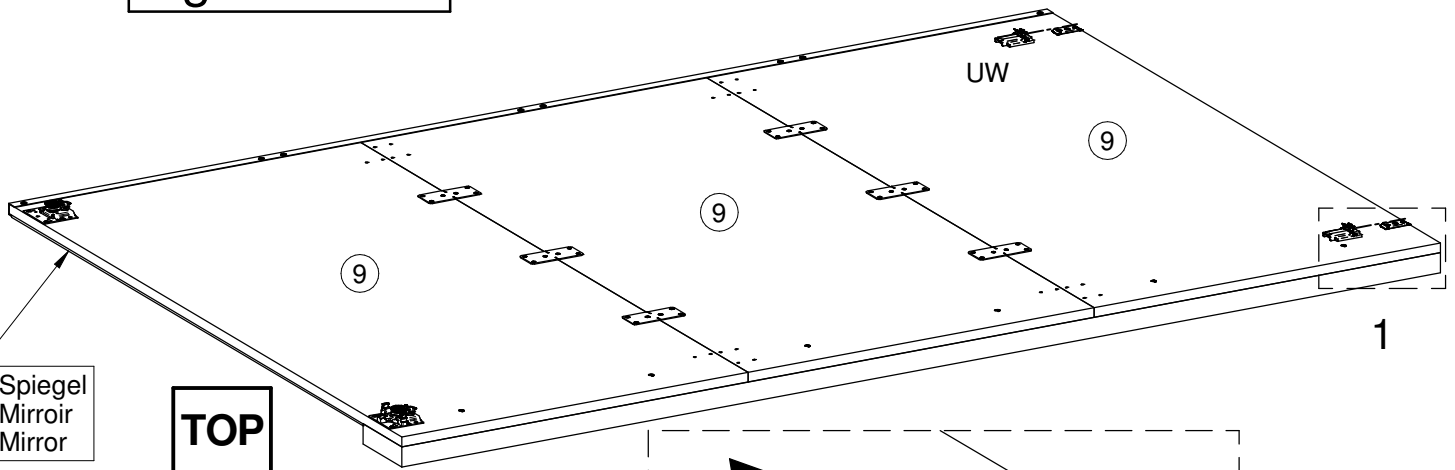

Spiegel
Mirroir
Mirror

TOP

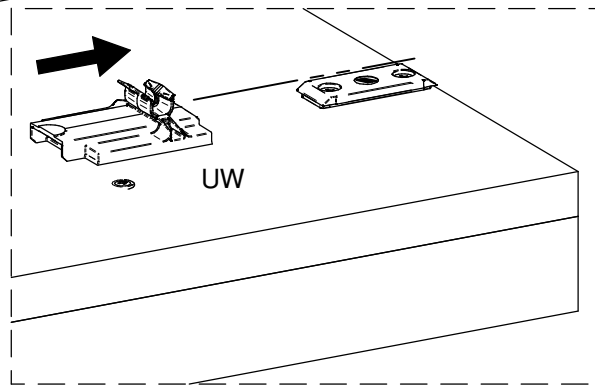

DETAIL 1

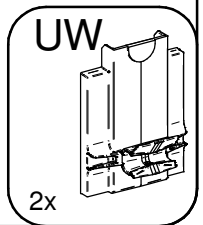

50

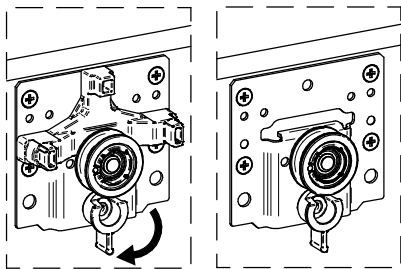

Open
Ouvert 1
Open

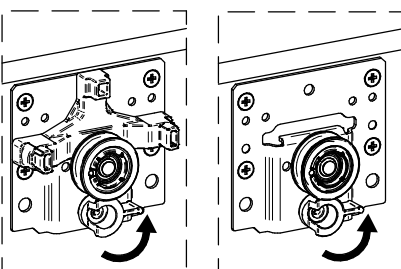

Gesloten
Fermé 4
Closed

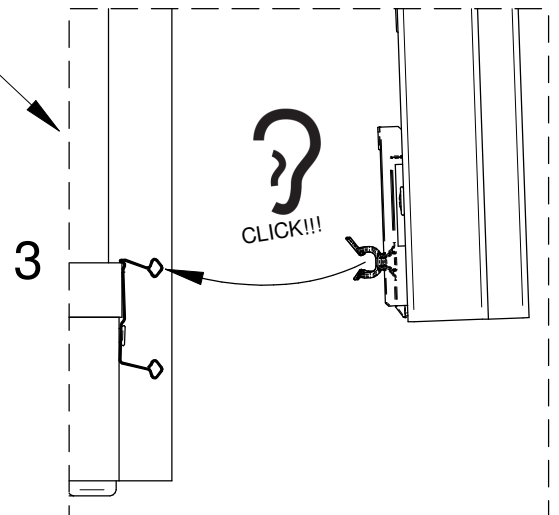
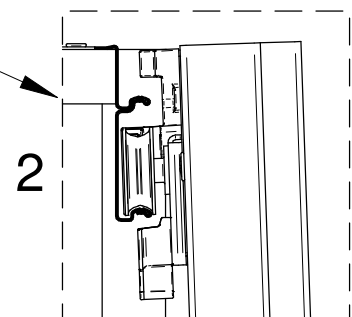
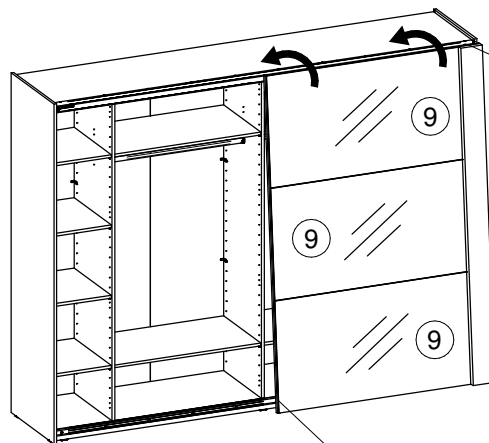

51

- Neem de linkse deur vast met twee personen.
- Saisissez la porte gauche à deux personnes.
- Take the left door with two persons.

52

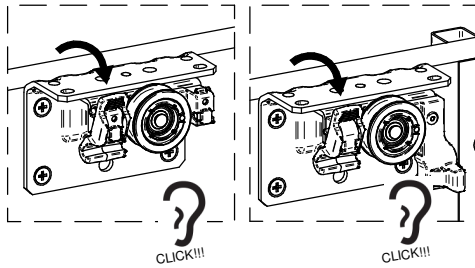

Open

Ouvert 1

Open

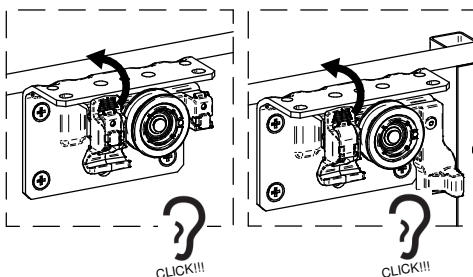
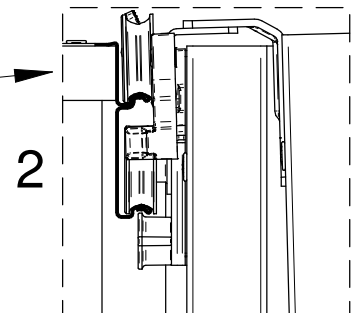
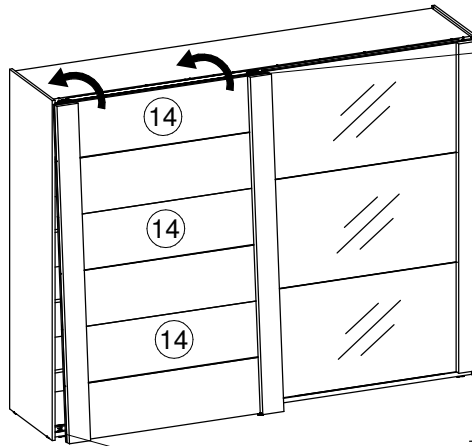

Gesloten

Fermé 4

Closed

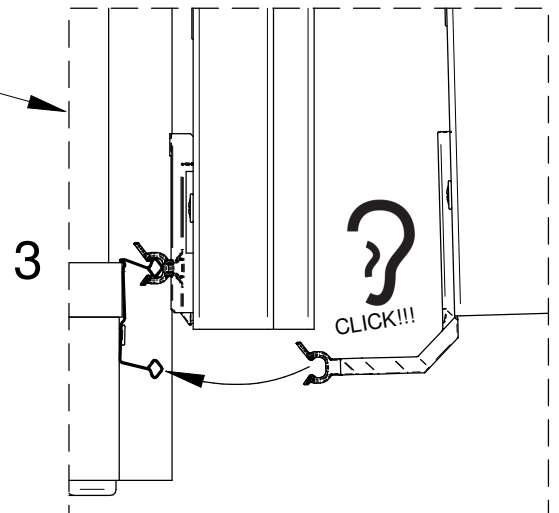

53

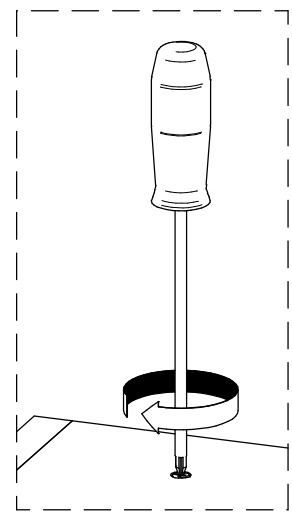
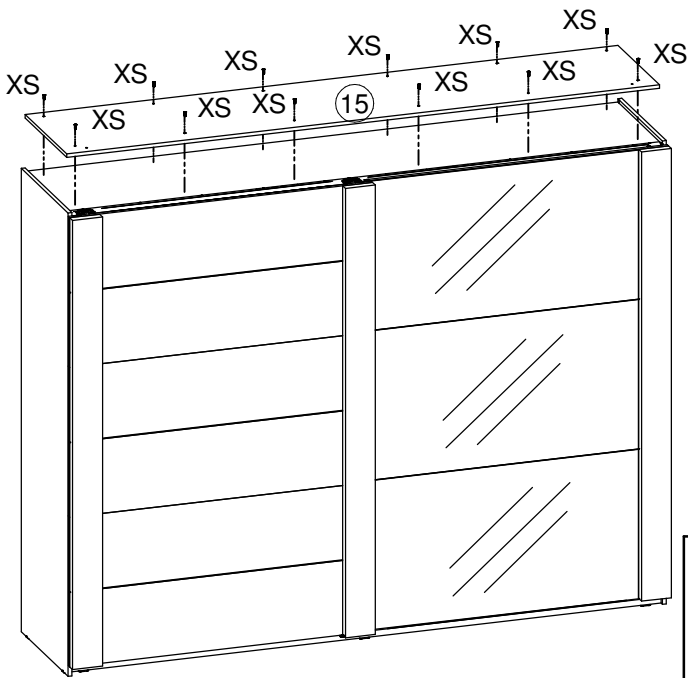

*Het aantal schroeven is afhankelijk van de kastbreedte
 *Le nombre de vis dépend de la largeur de l'armoire
 *The number of screws depends on the width of the cabinet

Effen
 Égale
 Equal

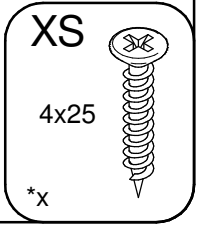
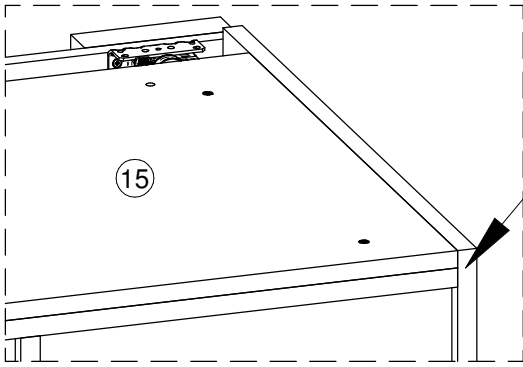

54

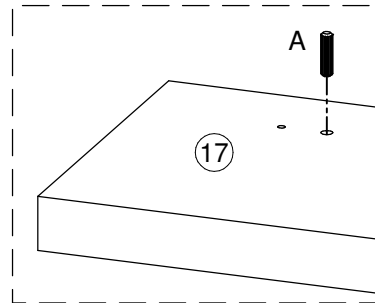

DETAIL 1

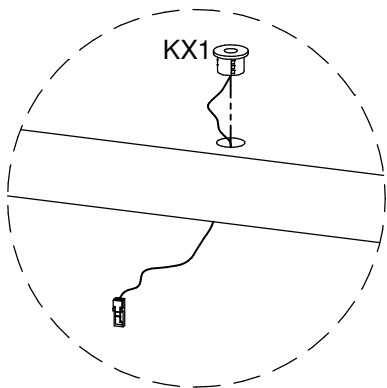
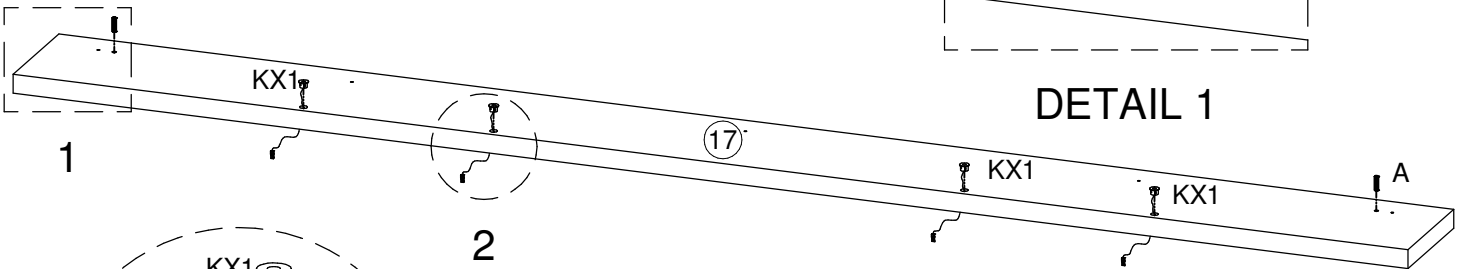

DETAIL 2

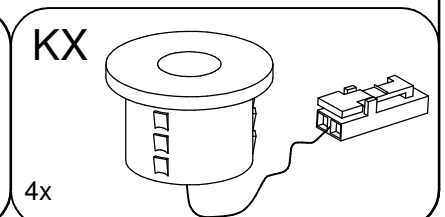
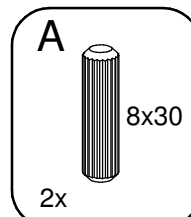

55

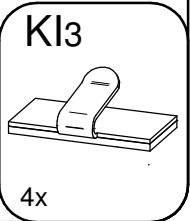
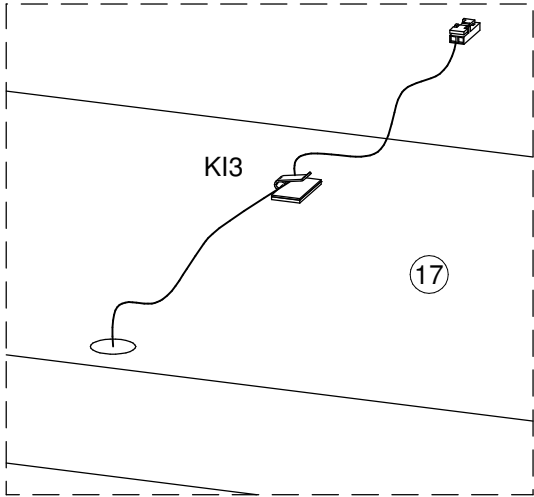
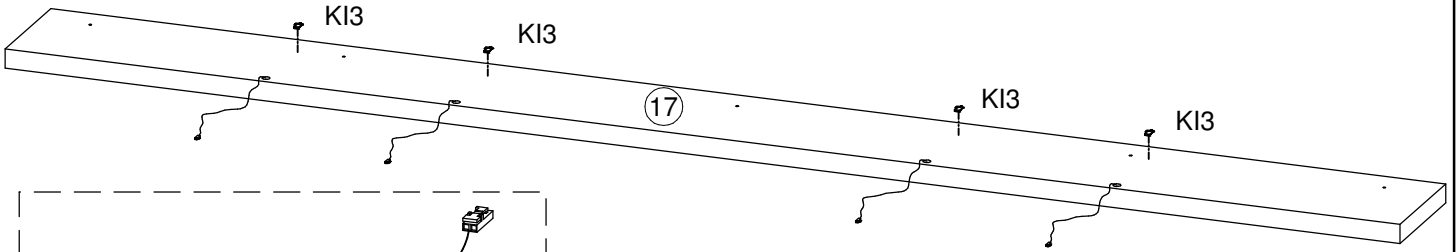
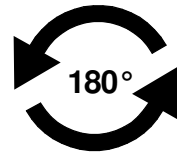
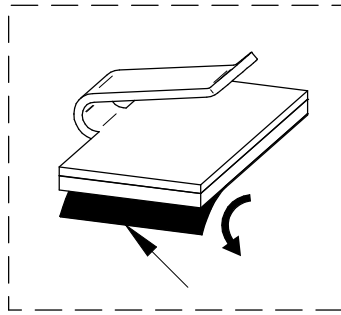

56

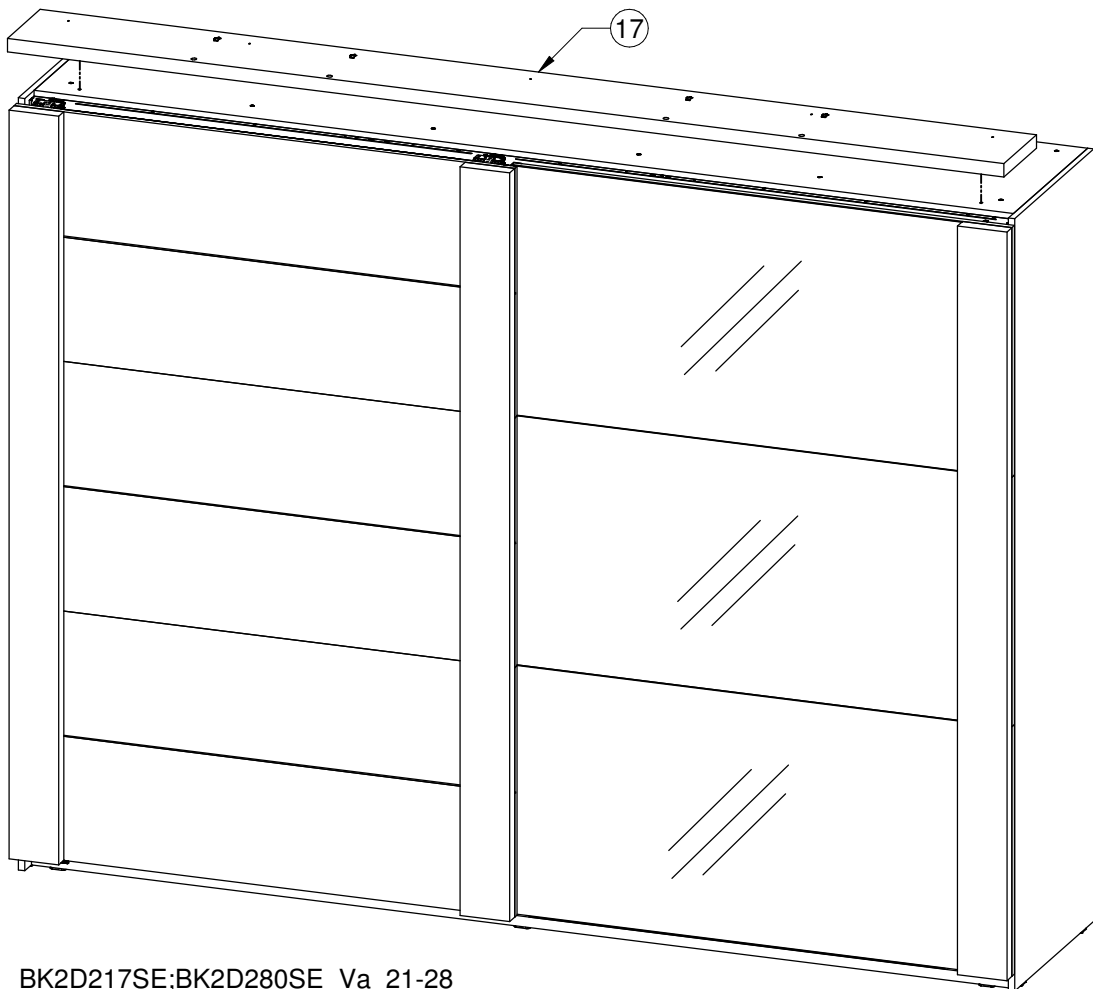
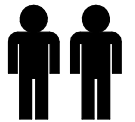

57

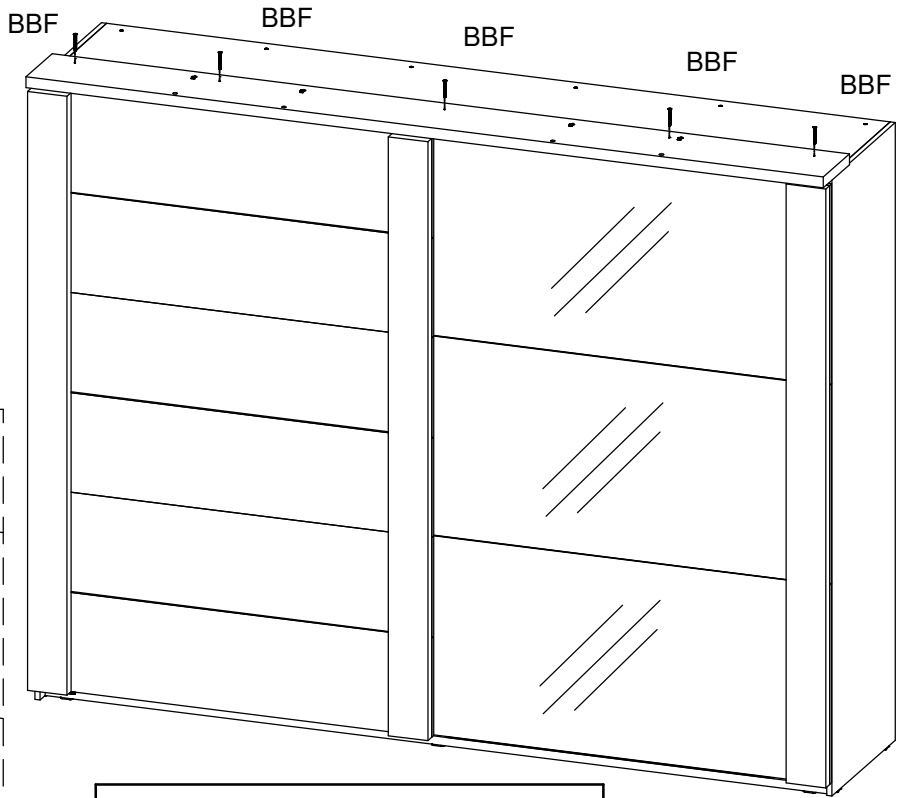

*Het aantal schroeven is afhankelijk van de kastbreedte
 *Le nombre de vis dépend de la largeur de l'armoire
 *The number of screws depends on the width of the cabinet

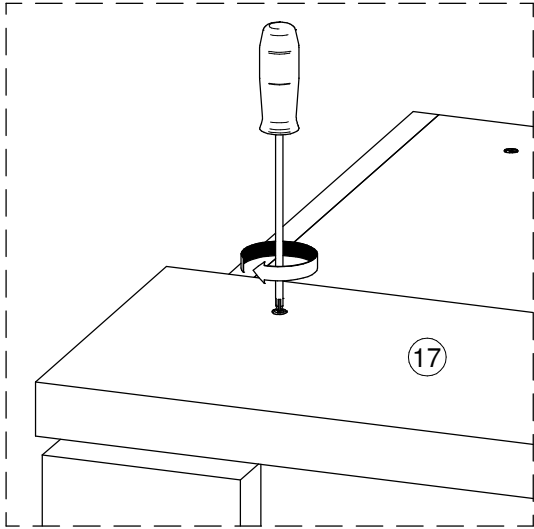
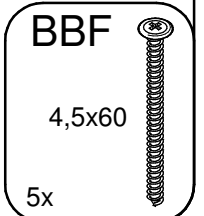

58

Effen
 Égale
 Equal

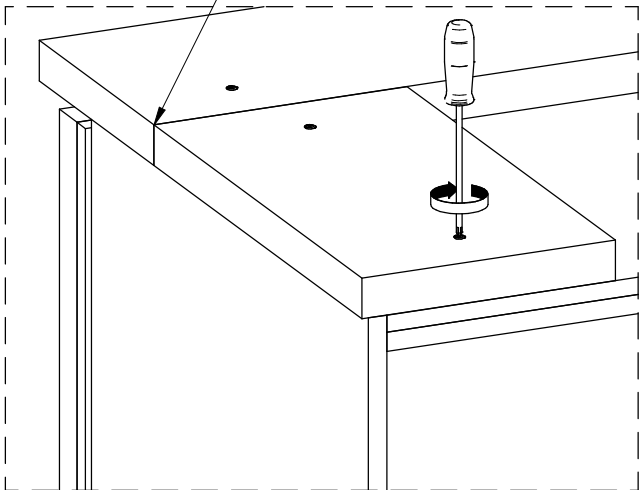
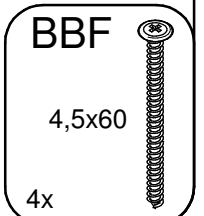
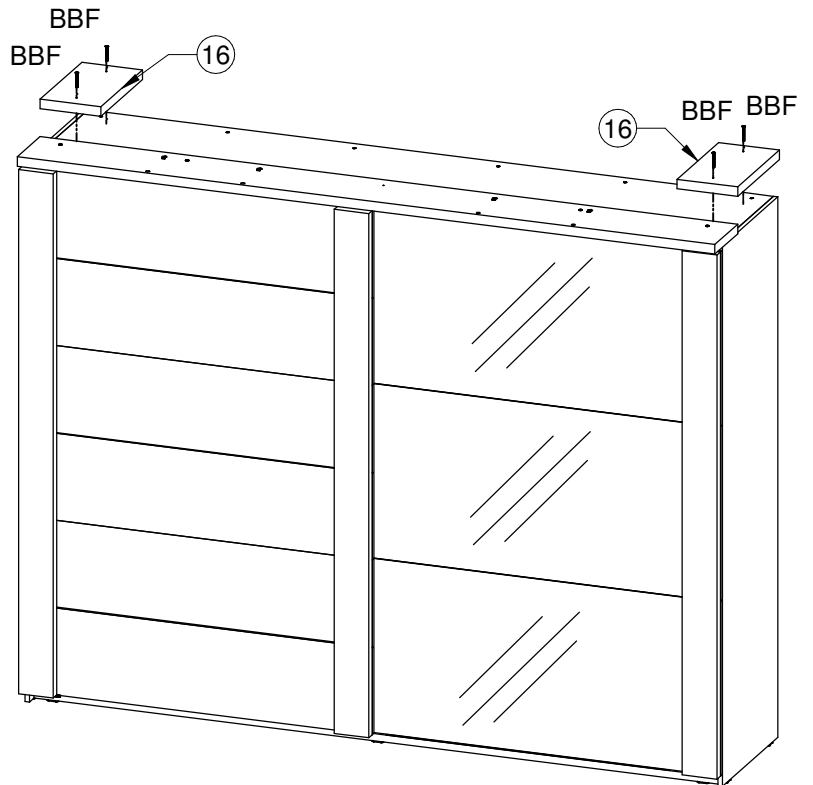

59

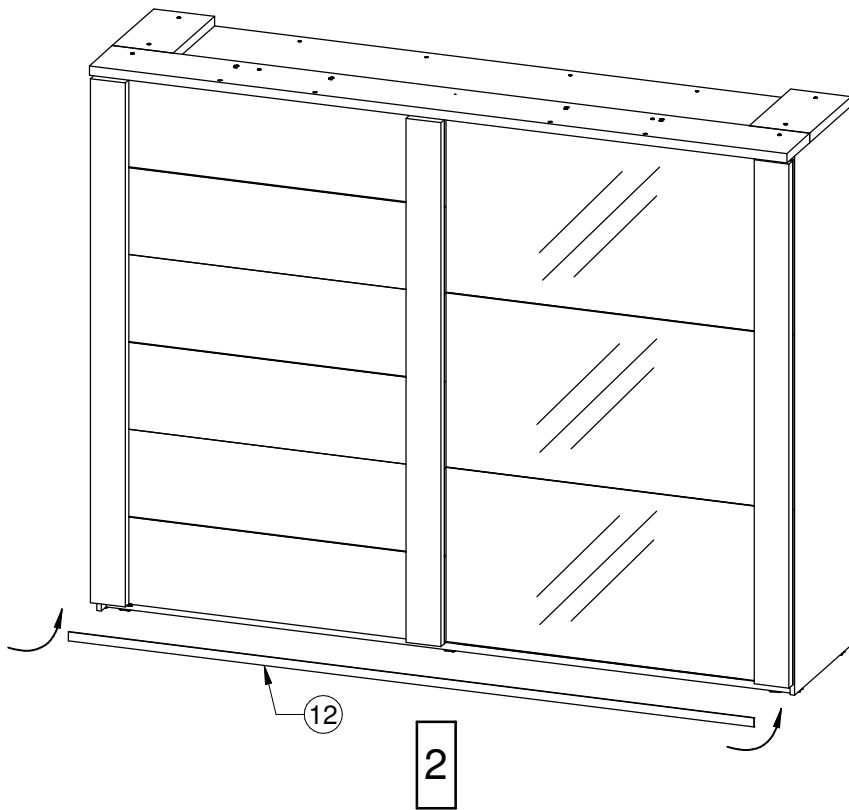
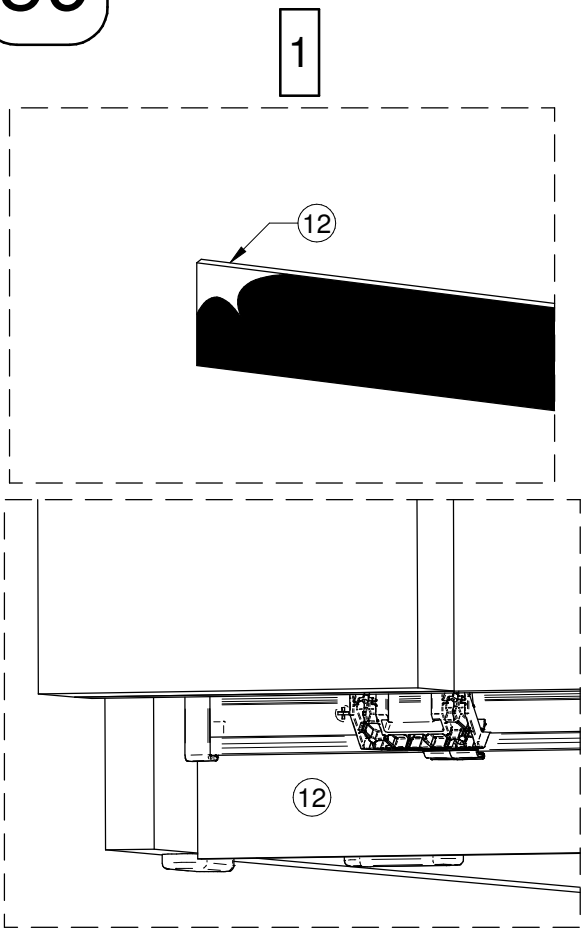

60

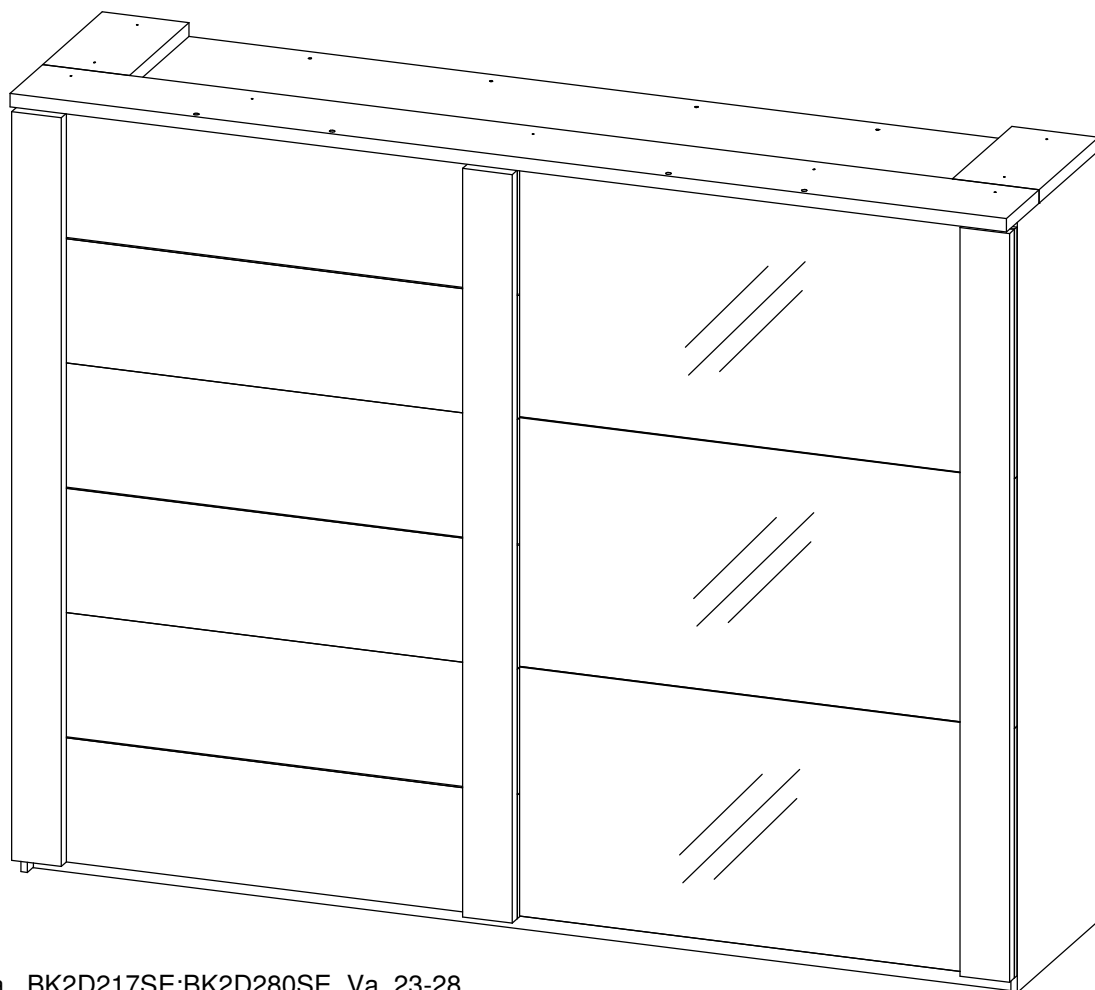

61

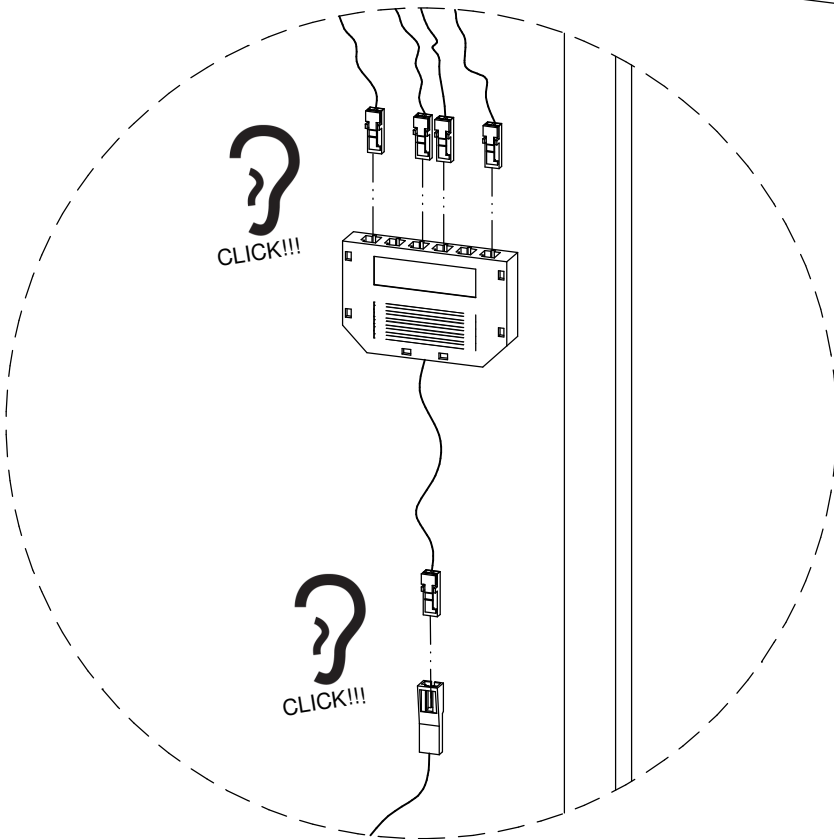
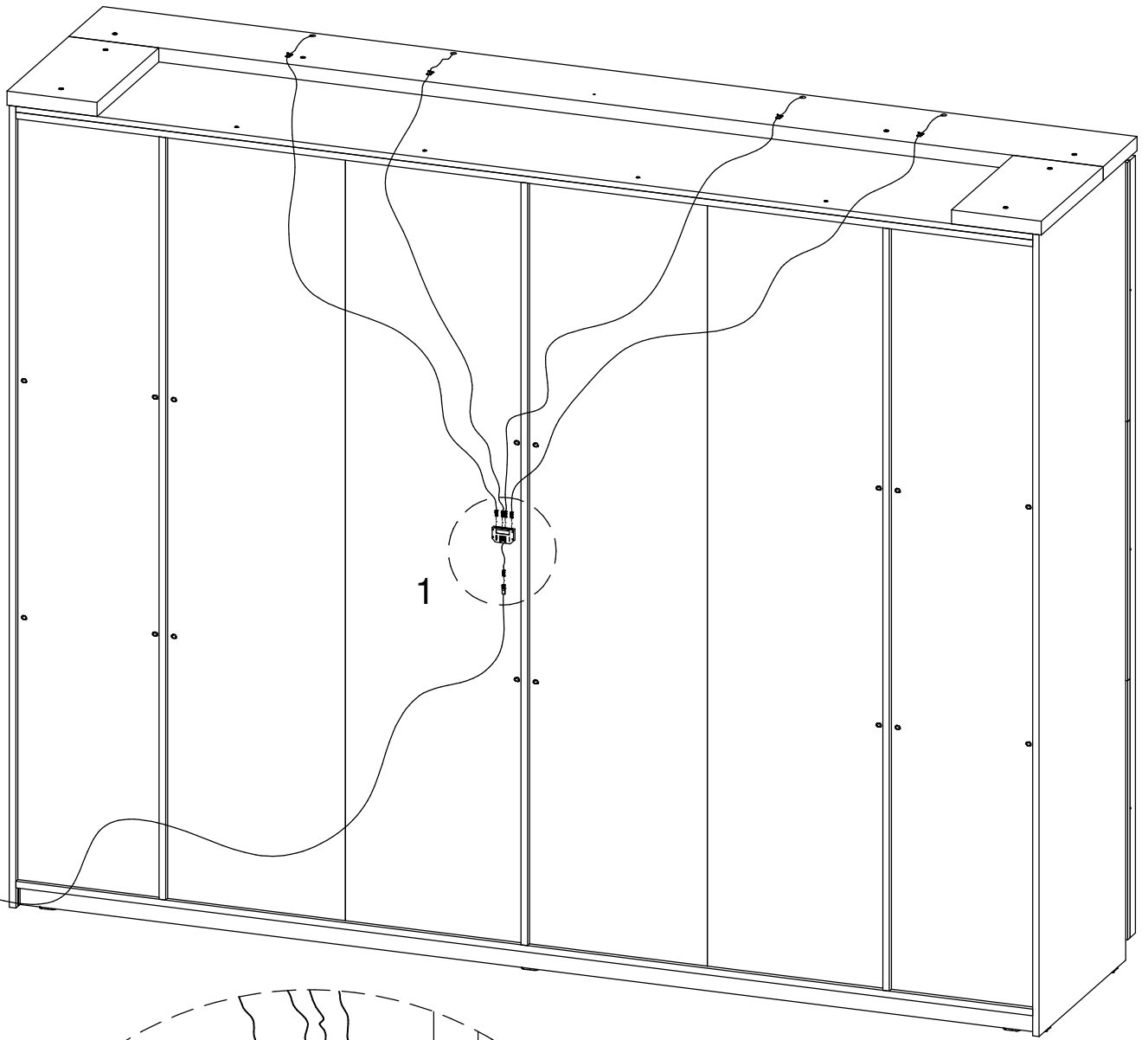

DETAIL 1

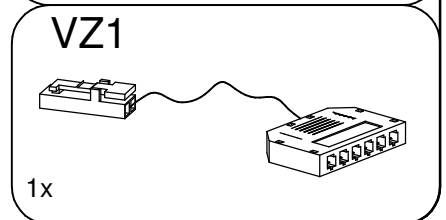
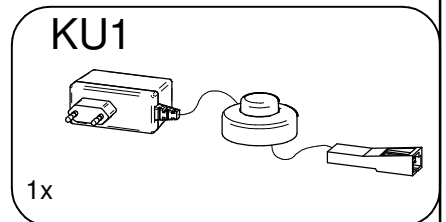

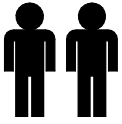

Demontage deuren Démontage des portes Disassembly of doors

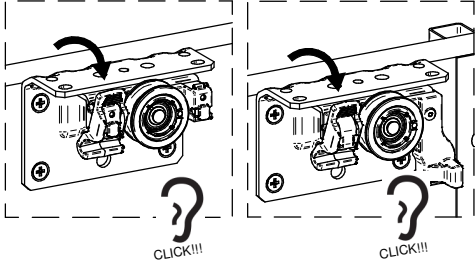

Open
Ouvert **1**
Open

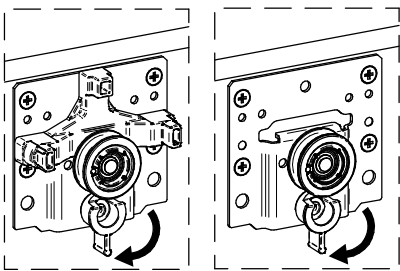
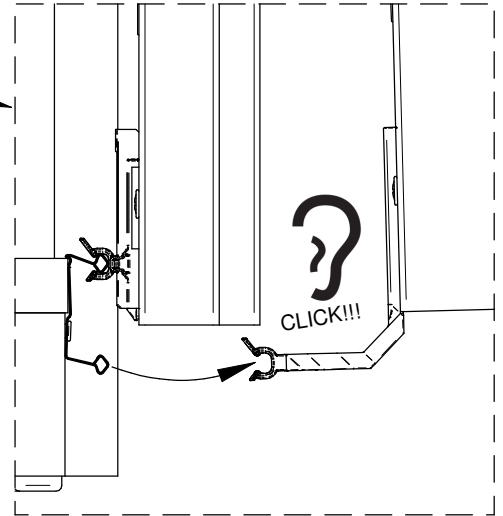
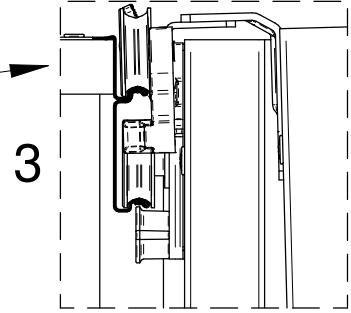
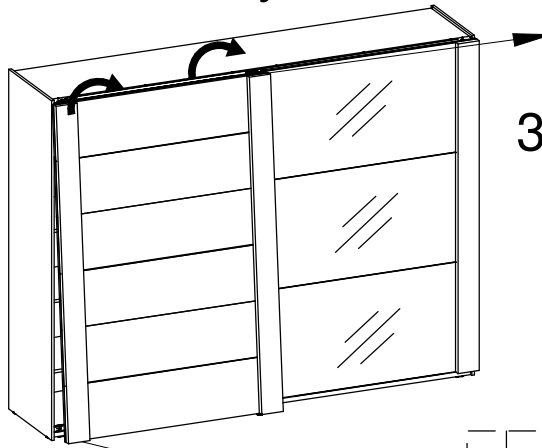

Open
Ouvert **4**
Open

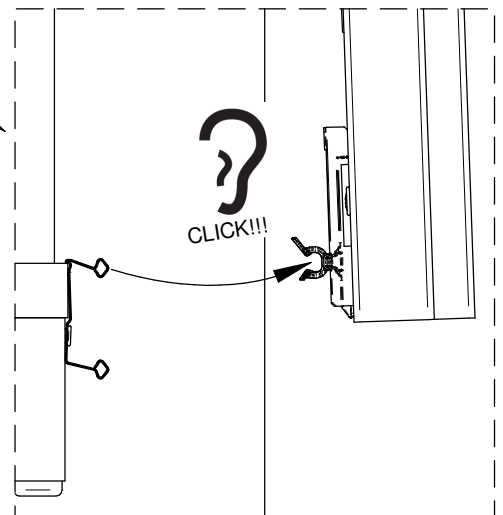
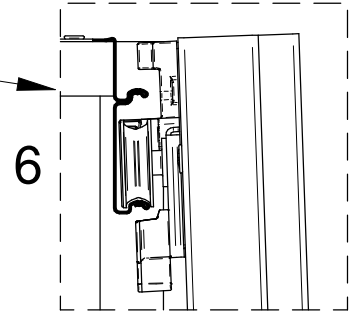
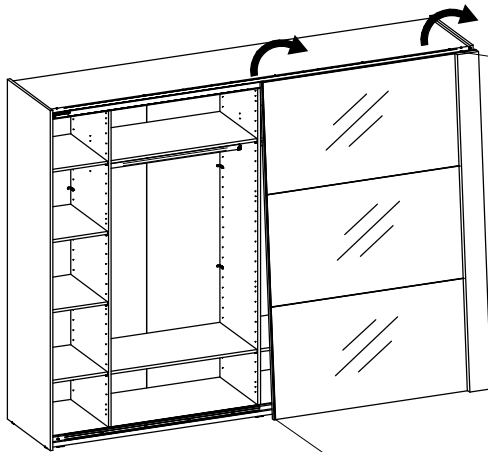

Onderhoud - Entretien - Maintenance

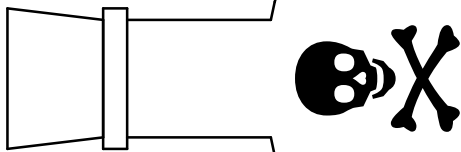

Oplosmiddel
Reinigingsmiddel
Verdunner
Chemische producten
Boenwas

NL

Solvant
Détergent
Diluant
Produits chimiques
Cirage

FR

Solvent
Cleaner
Thinner
Chemical products
Wax

GB

Algemene informatie: Voor tafels geldt geen hete pannen, theeglazen en waxinelichtjes op de ondergrond plaatsen. Gebruik hiervoor altijd een onderzetter. Het meubel leegmaken en niet verslepen op de vloer bij eventuele verplaatsing.

Onderhoud: Met licht vochtige doek reinigen en hierna direct droog wrijven. Vocht op het bovenblad direct opnemen. De meubels zijn niet voor vochtige ruimten bestemd. Gebruik nooit een schuurspons, schuurmiddel, amoniak, oplosmiddel, reinigingsmiddel, verdunner, chemische producten, boenwas of producten zoals Pledge-was of dergelijke. Montage tekening opbergen.

Service na verkoop: Voor service na verkoop, ga naar uw leverancier met deze montage tekening.

Garantie: Het niet naleven van deze onderhoudsvoorschriften doet de garantie met onmiddellijke ingang verloren gaan.

NL

L'information générale: Ne mettez jamais des casseroles chaudes, des verres à thé sur la surface des tables. Veuillez utiliser des sous verres. Videz le meuble avant tout déplacement. Portez le meuble et non pas le pousser sur le sol!

Entretien: Utilisez un chiffon légèrement humide et sèche aussitôt. Toute trace de liquide doit être enlevé immédiatement.

Les meubles ne sont pas adaptés aux pièces humides. N'utilisez jamais des éponges abrasives, amoniak, solvant, détergent, diluant, produits chimiques, cirage, des produits d'entretien comme Pledge etc.... . Notice de montage à conserver.

Service après-vente: Pour tout service après-vente, rendez vous au magasin avec cette notice.

Garantie: Nous vous informons qu'en cas de non respect aux prescriptions sus - mentionnés que la garantie expire immédiatement.

FR

General information : Never put hot items on the table tops!

Empty furniture before moving it and do not drag the furniture over the floor.

Maintenance : Clean with slightly wet moistened cloth, wipe dry immediately. Wipe off wetness at once.

Not suited for humid locations. Never use solvent, cleaner, thinner, chemical products or wax. Retain manual instruction.

For the after sales : For the after sales, go back to the shop with this assembly instruction.

Guarantee : Attention in case of non respect to the above prescriptions the warranty expires immediately.

GB

Formulier DNV - Formulaire SAV - Form SAS

Terug te sturen naar uw winkel / A renvoyer à votre magasin

/ Send back to the shop

Datum / Date :

Uw gegevens / Vos donnees / Your data

Naam / Nom / Name :

Adres / Adresse / Address :

E-mail :

Tel. / GSM / Mobile :

Gegevens over het probleem / Donnees sur le problème / Information about the problem

Datum aankoop / Date d'achat / Date of purchase :

Naam model en meubelonderdeel :

Nom modèle et partie du meuble:

Name model and piece of furniture:

Onderdeelnr. of colli nr. (zie montageplan) :

N° de pièce ou coli (voir le plan de montage):

Number piece or coli number (view assemble plan):

Kleur of stof / Couleur ou tissu / Color or cloth:

Digitale foto's in bijlage / Photos digitales en annexe / Digital photos attached: **YES/ NO**

Gedetailleerde omschrijving van het probleem:

Description détaillée du problème:

Detailed description of the problem:



Dienst na verkoop



Beste klant,

Wij danken u voor de aankoop van dit meubel. Ondanks de zorg die wij besteden aan de productie en verpakking van onze meubelen, kan het voorkomen dat er iets ontbreekt of beschadigd is.

Is dit het geval vragen wij u om via bijgaand formulier uw DNV te melden aan de winkel waar u uw meubel heeft aangekocht.

Volg volgende onderstaande stappen in geval van schade:

1. Een foto van het complete meubel (onderdeel)
2. Een detailfoto van het probleem

Op die manier kunnen wij u zo vlug mogelijk helpen om uw probleem op te lossen.

Met vriendelijke groeten,



Service après vente



Cher client,

Nous vous remercions pour l'achat de ce meuble. Malgré tout les soins que nous consacrons à la production et le conditionnement de nos meubles, il est possible que quelque chose est manqué ou endommagé.

Si c'est le cas, nous vous demandons d'utiliser le formulaire ci-joint pour déclarer votre plainte au magasin où vous avez acheté vos meubles.

En cas de dommages, nous vous demandons également de prendre les photos suivants et de nous les envoyer:

1. Une photo du mobilier complet (partie)
2. Une photo de détail du problème

De cette façon, nous pouvons vous aider le plus vite possible afin de résoudre votre problème.

Sincèrement,



Service after sale



Dear customer,

Thank you for purchasing this piece of furniture. Despite the care we take in the production and packaging of our furniture, it is possible that something is missing or damaged.

If this is the case, we ask you to use the enclosed form to report your SAS to the store where you purchased your furniture.

Follow the steps below in case of damage:

1. A photo of the complete furniture (part)
2. A detailed photo of the problem

In this way we can help you solve your problem as quickly as possible.

With best regards,