

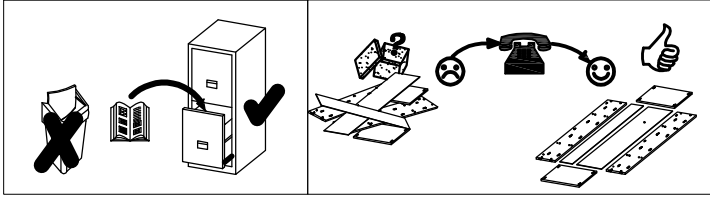

# VERA 51/52

Instrukcja montażu  
Montageanleitung  
Instructions D'assemblage  
Assembly instructions

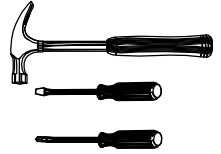
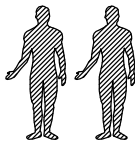

10X35  A	 B	6.3X13  C	6.3X13  D
2	4	12	4
4.0X16  E	 F	 H	
16	1	2	

 J
4

51 -	VZ-941	VZ-981	VZ-183
52 -	VZ-940	VZ-980	VZ-182

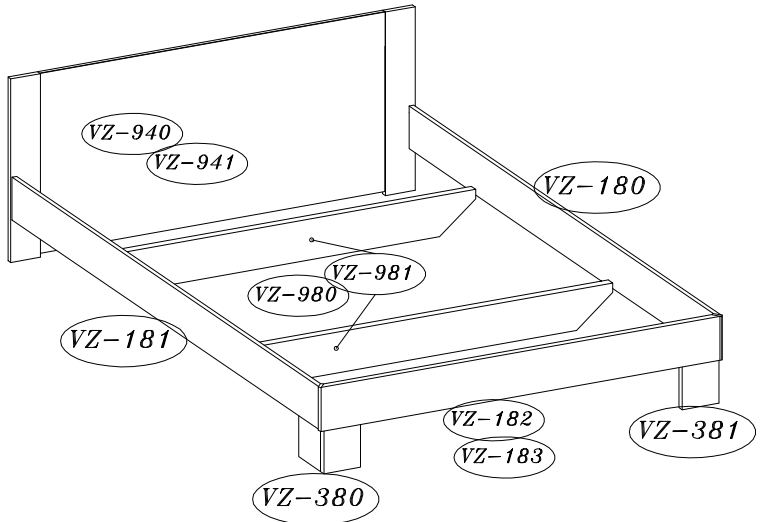

1

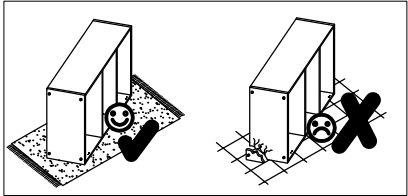
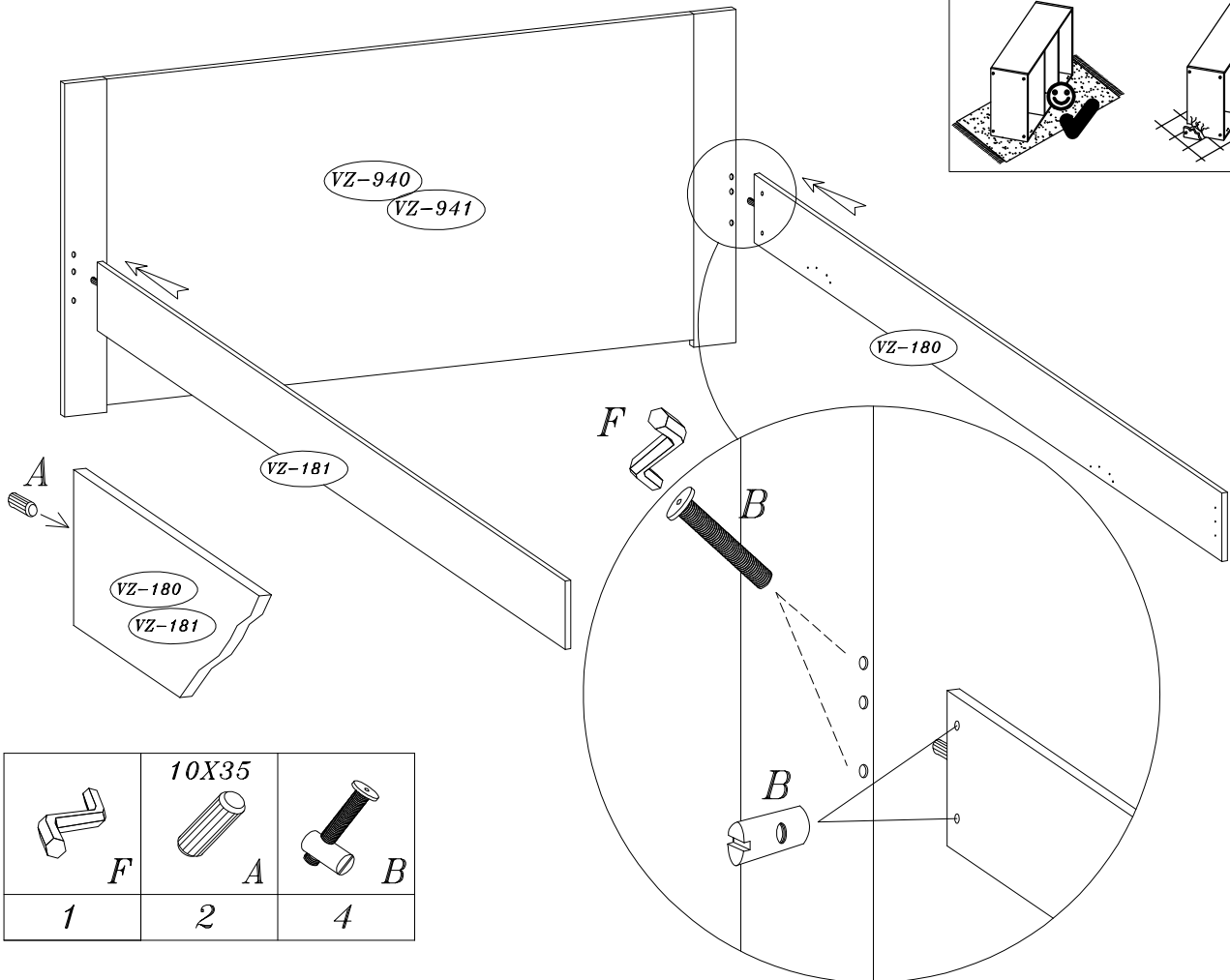

 F	10X35  A	 B
1	2	4

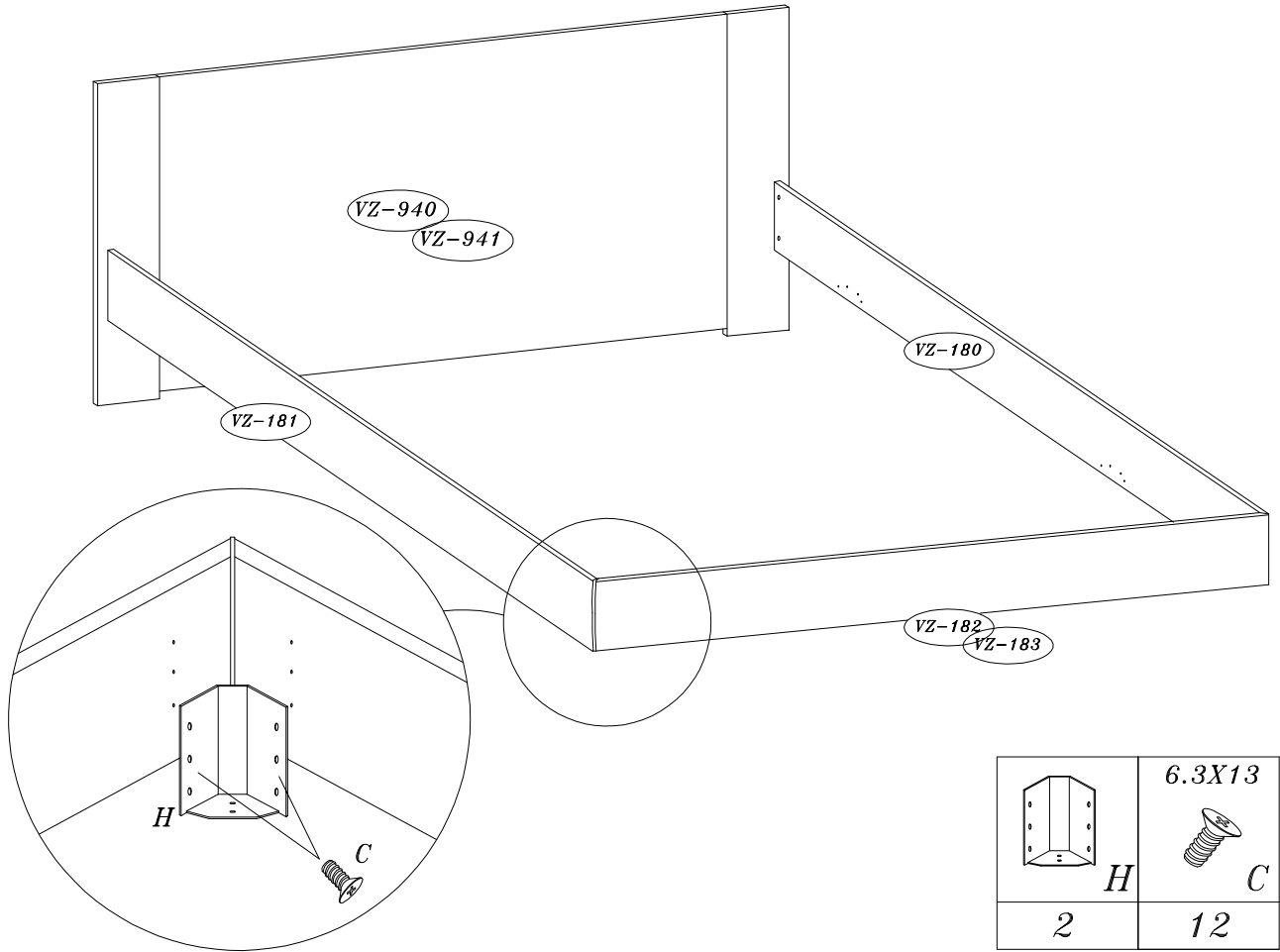

2

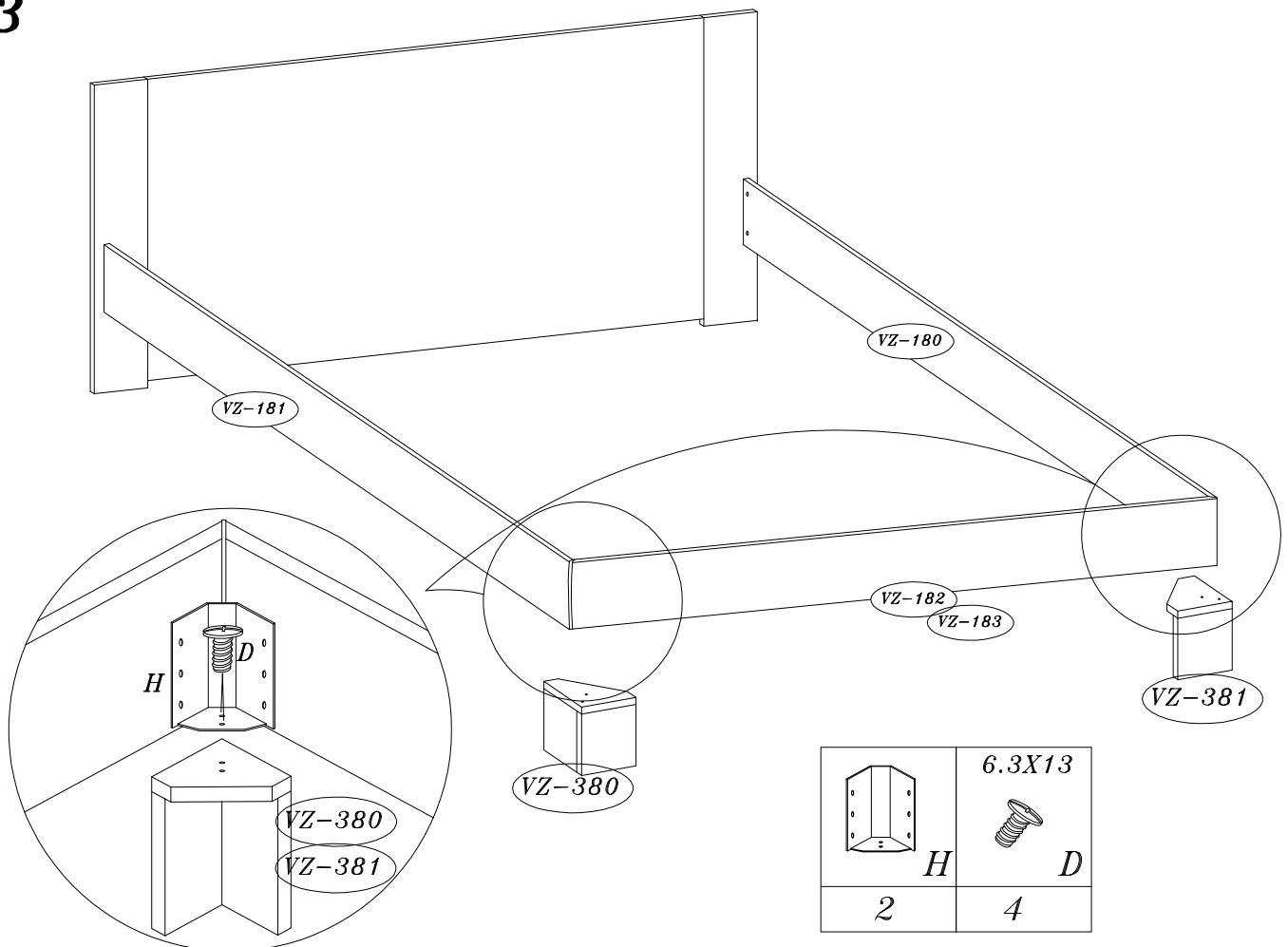

3

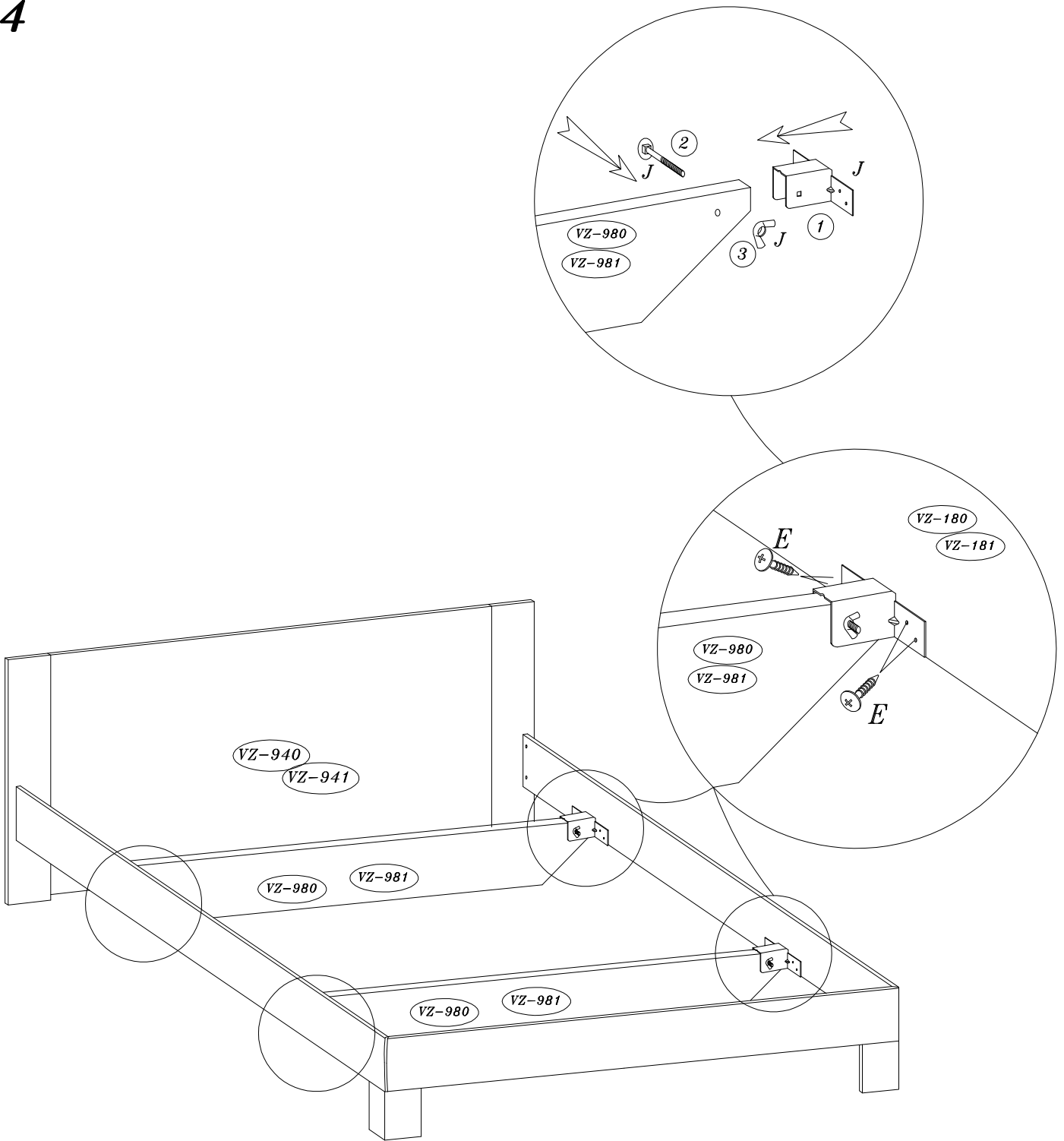

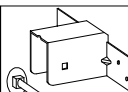







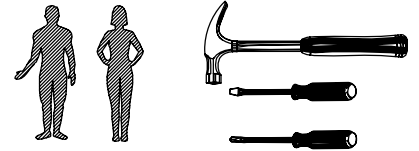
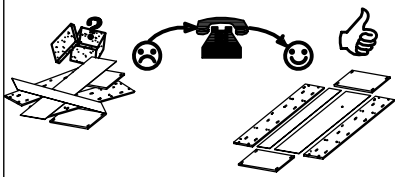
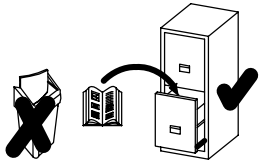

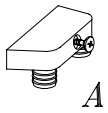
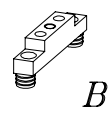
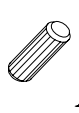
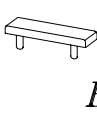

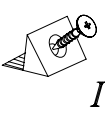
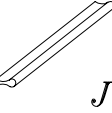
  <i>J</i>	<p>4.0X16</p>  <i>E</i>
<p>4</p>	<p>16</p>

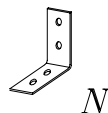
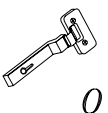
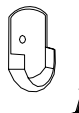
# VERA 20

Instrukcija montažu  
Montageanleitung  
Instructions D'assemblage  
Assembly instructions

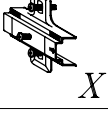

					6.3X11 			4.0X30 
16	16	8	10	12	12	16	2	6
			3.0X13 	3.5X13 				
12	12	2	2	48	1			
		4.0X13 						
20	12	16						

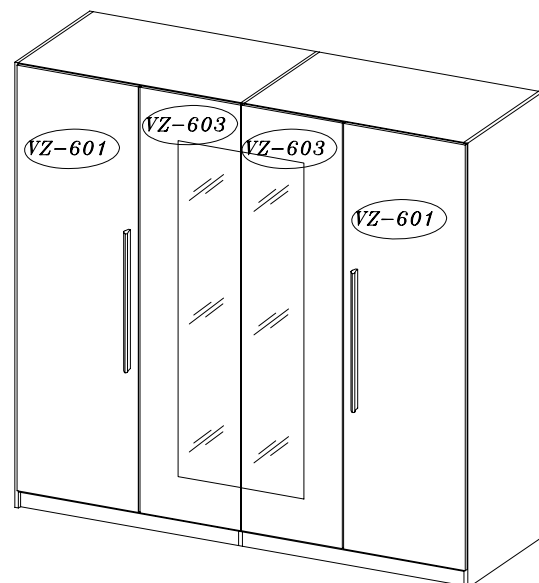
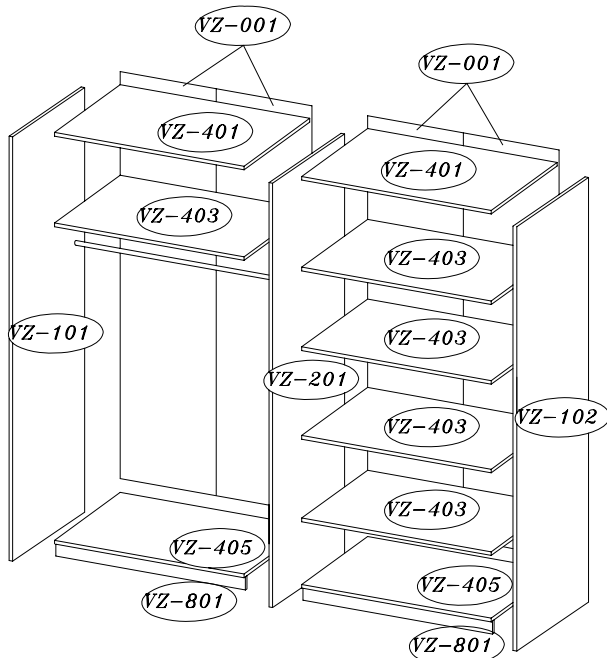
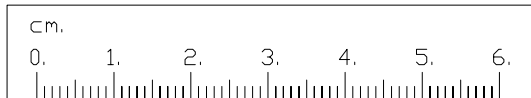

1

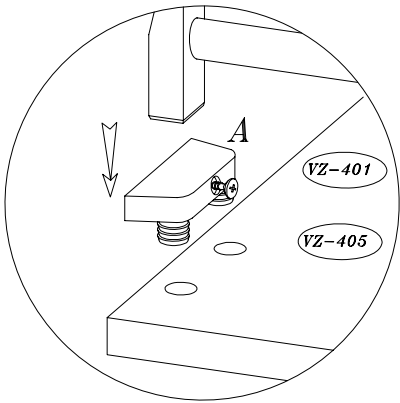
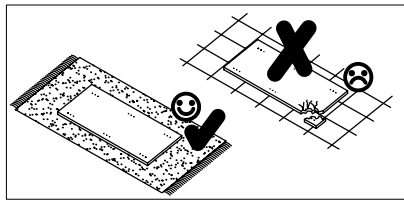

**ACHTUNG!**  
**PASSEN SIE AUF DIE RICHTIGE MONTAGE**  
**DER VERBINDUNGSBESCHLÄGE AUF**

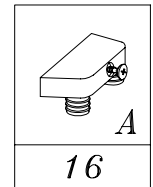
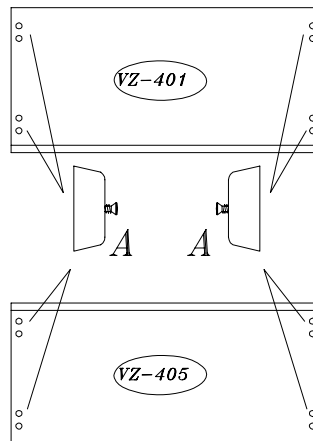
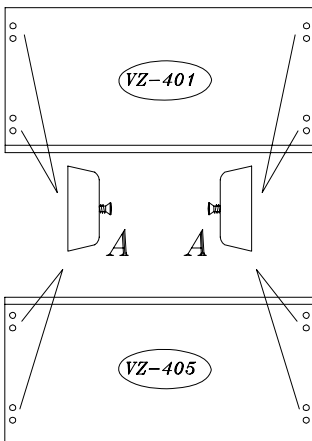
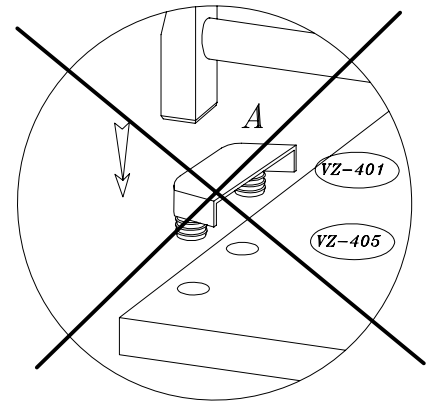

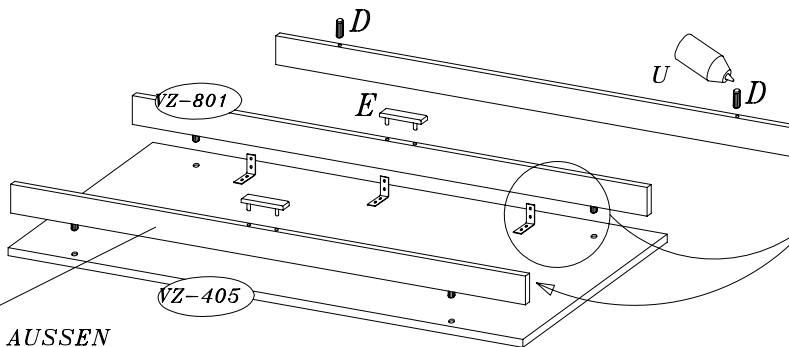
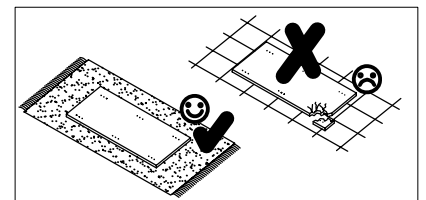

2

x2



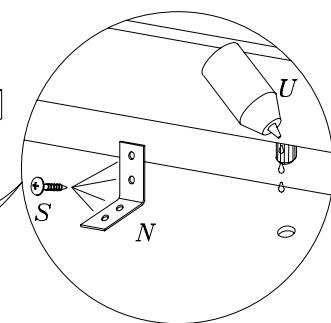

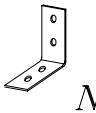
DEKO NACH AUSSEN

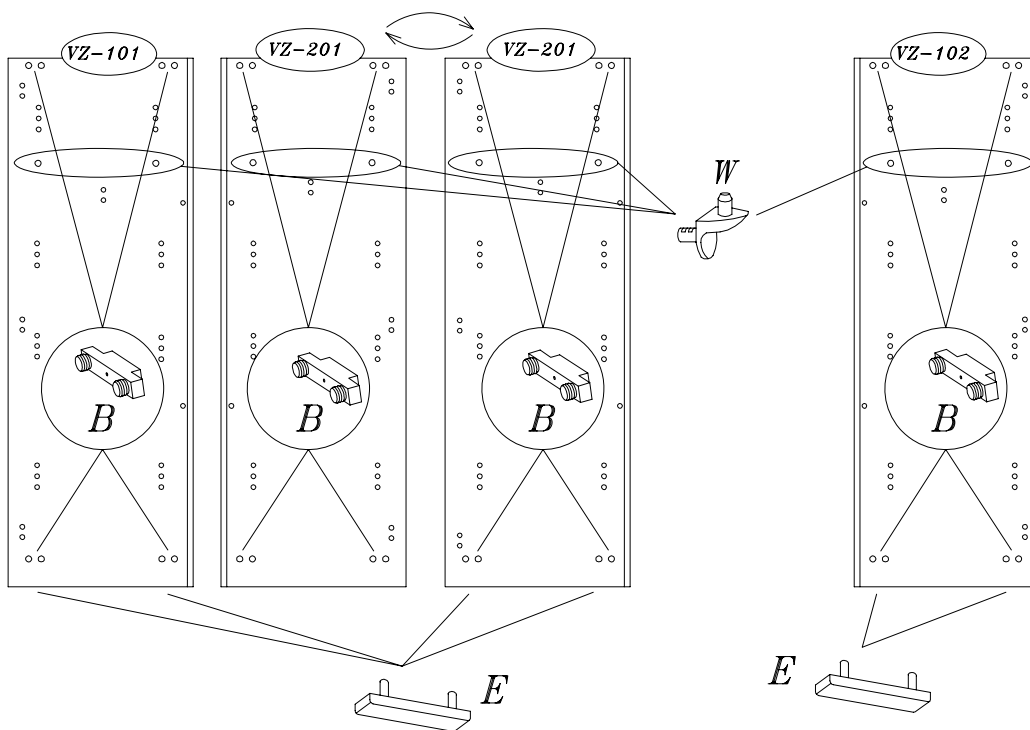
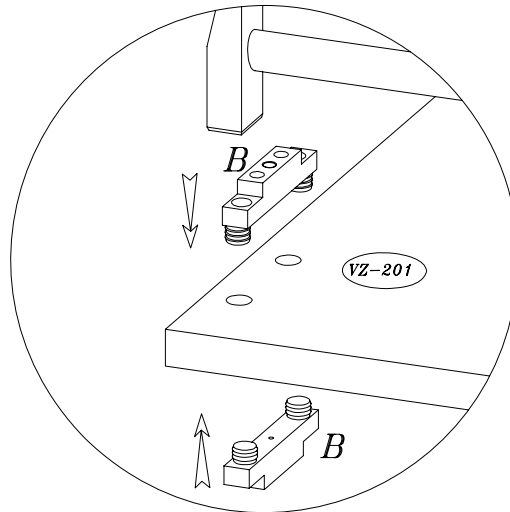
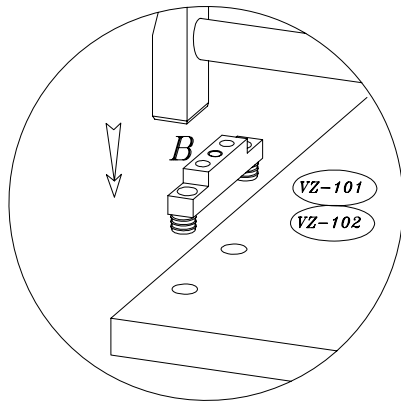
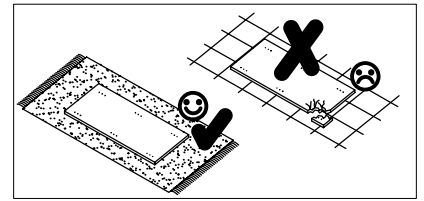

	3.5X13 	
N	S	U
12	48	1



		
<i>B</i>	<i>E</i>	<i>W</i>
16	6	8

4

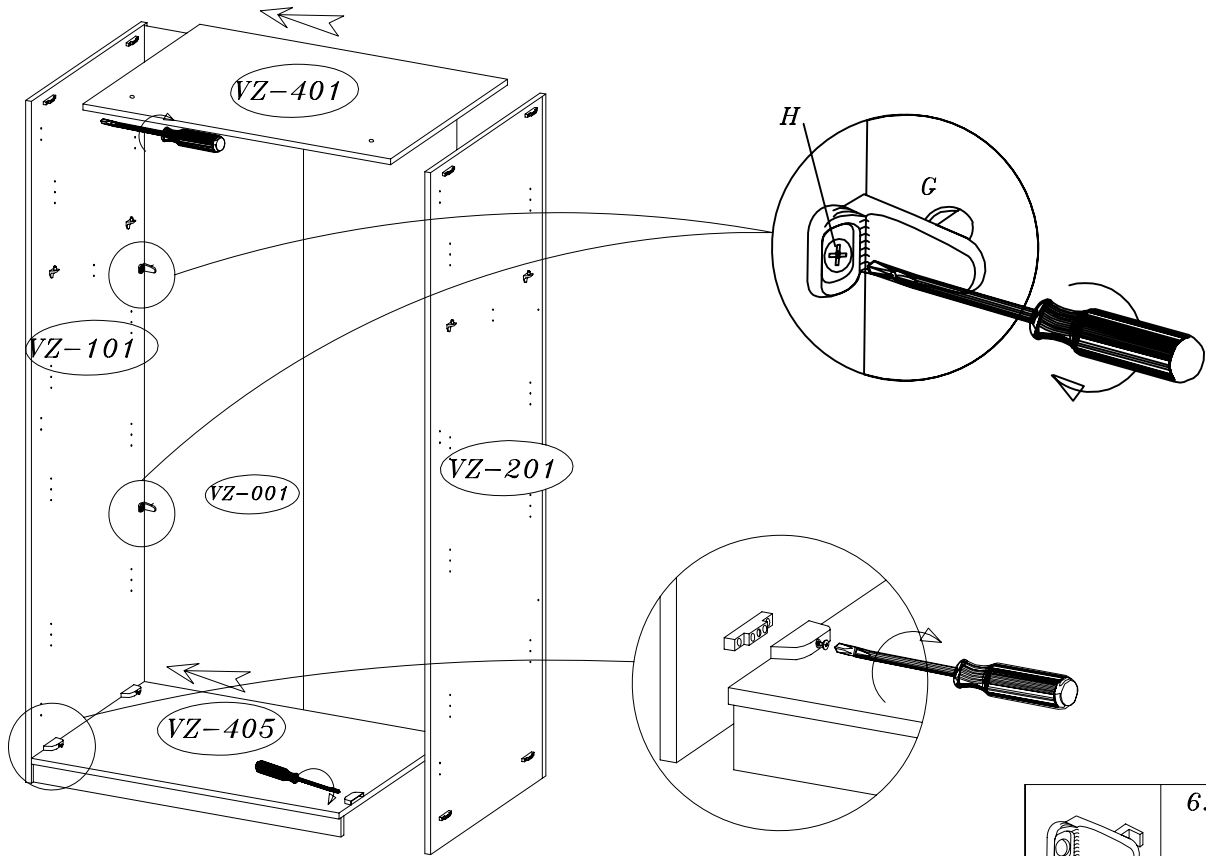

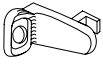
	6.3X11
G	H
2	2

5

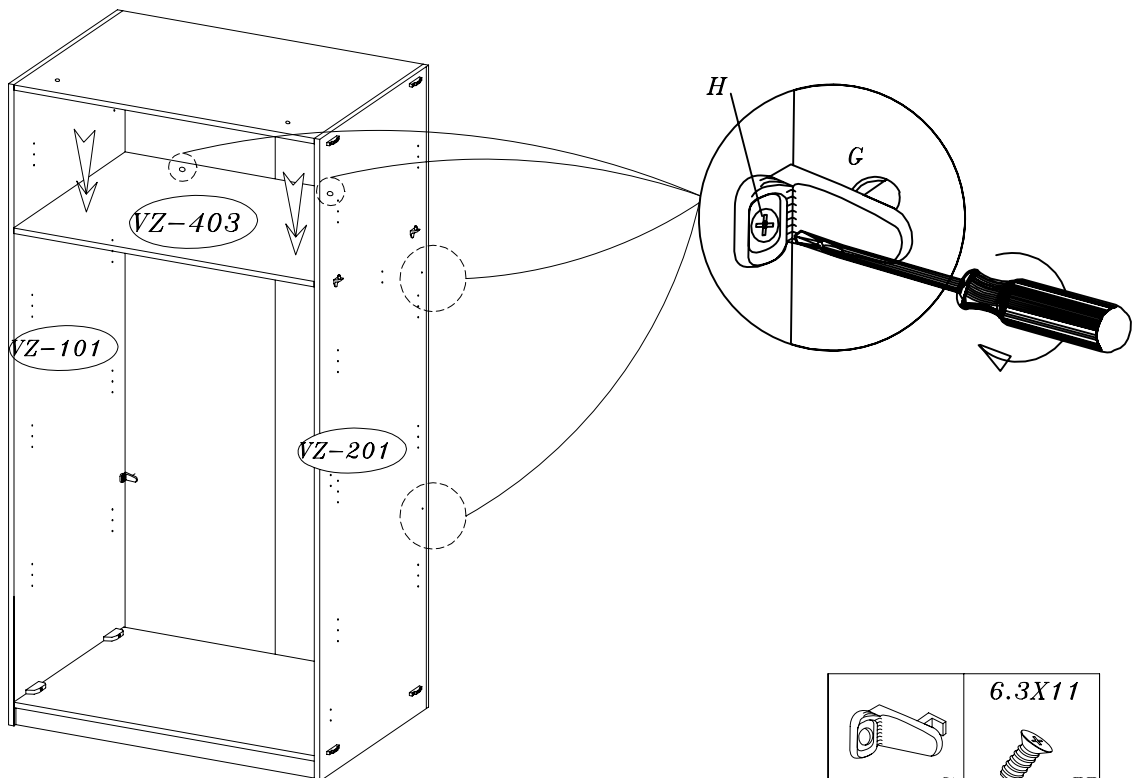

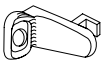
	6.3X11
G	H
4	4

6

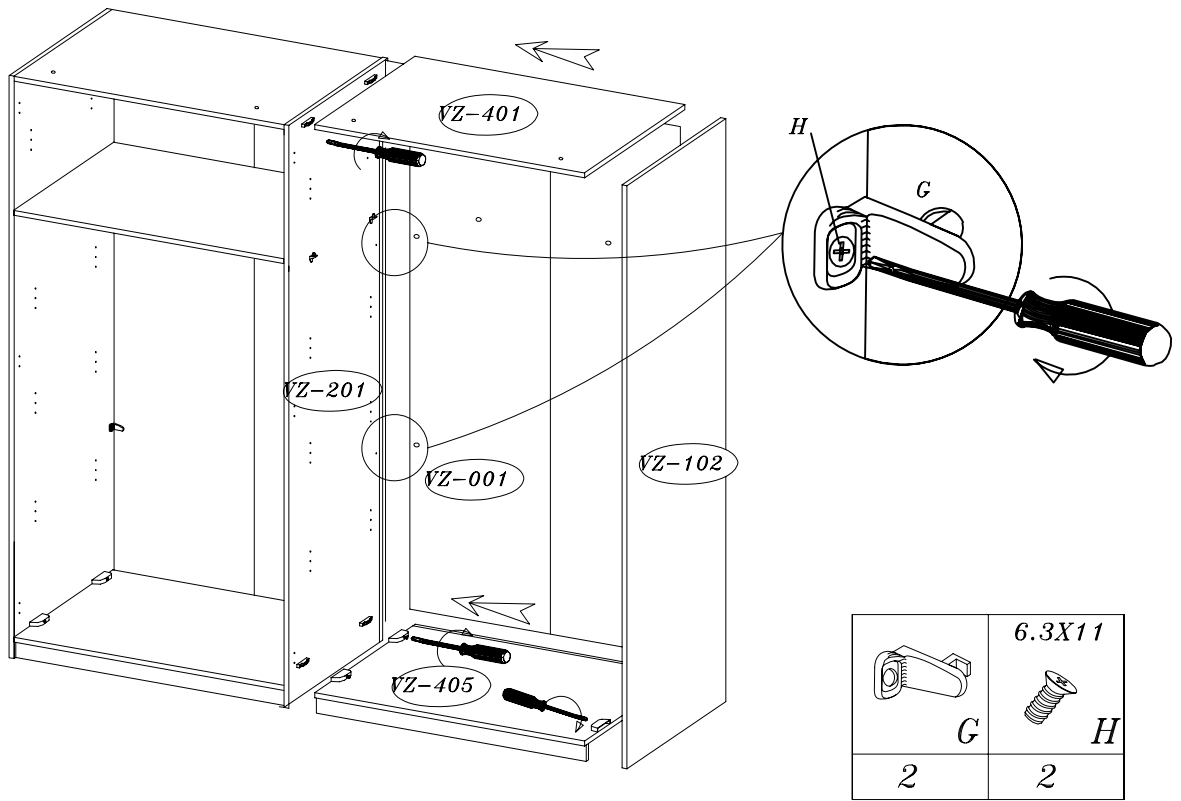

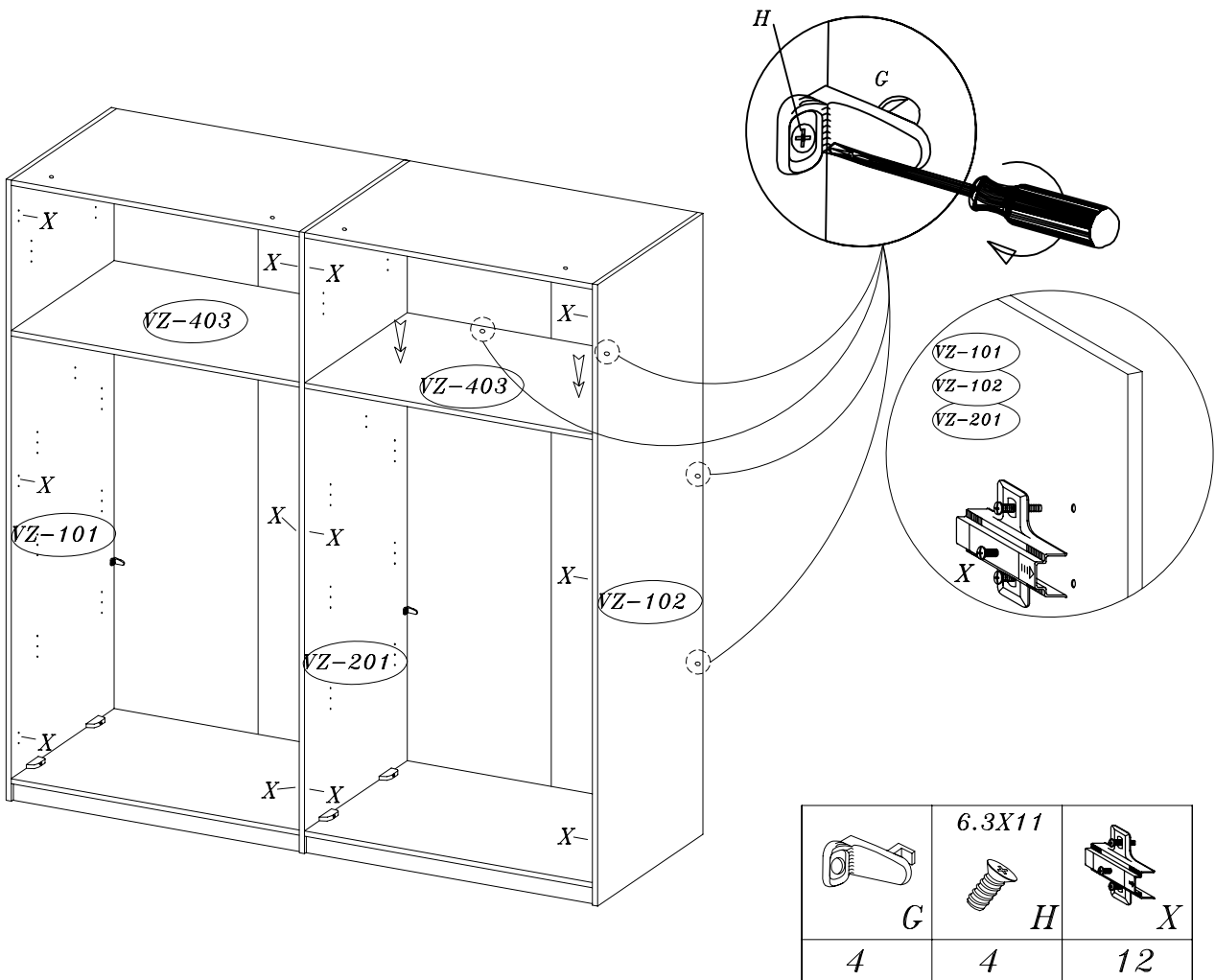

7





# 8

	3.0X13
P	R
2	2

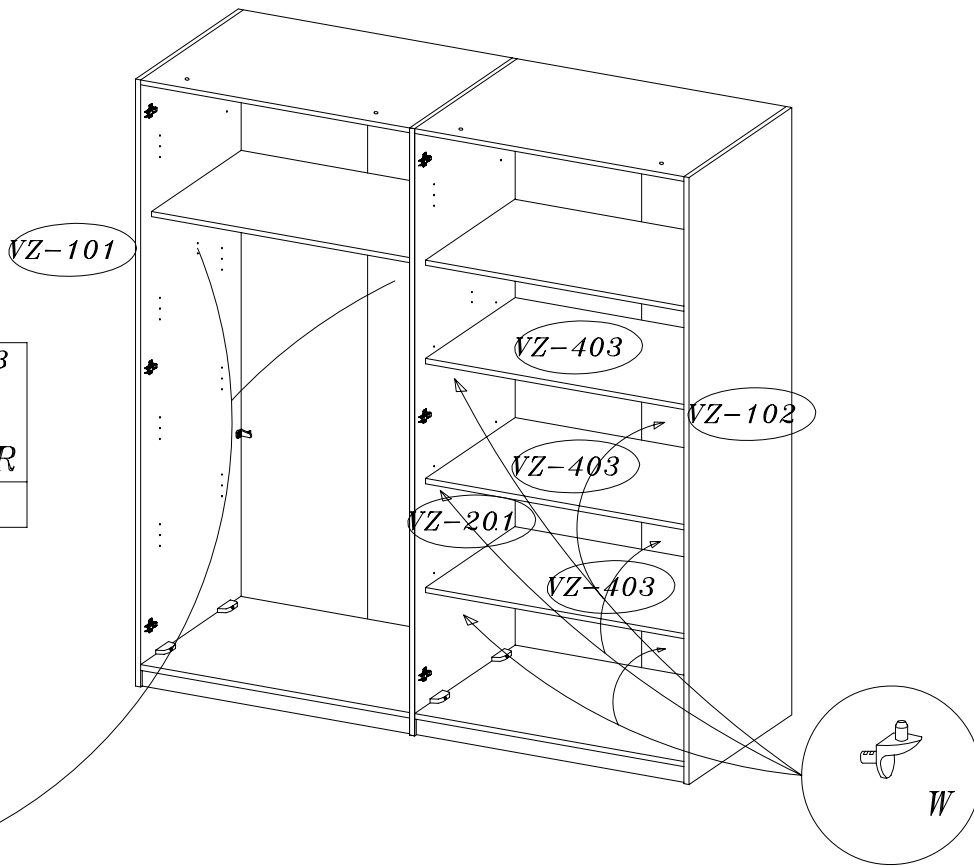
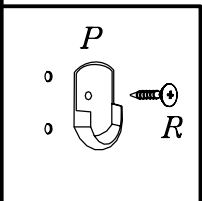

W
12

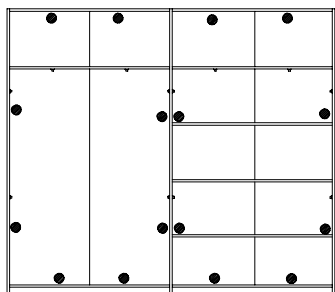
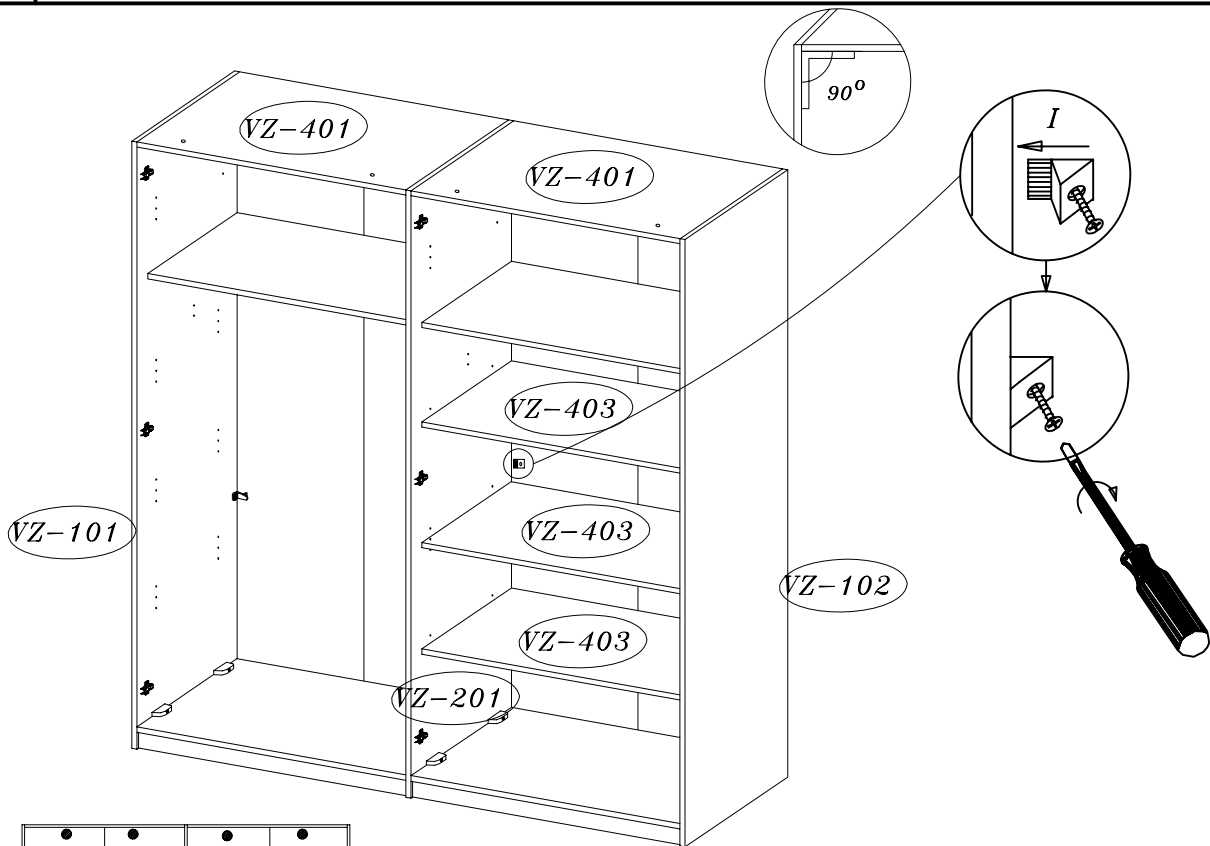

# 9

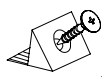

- PUNKTY MOCOWANIA ZACZEPÓW ŚCIAN TYLNYCH
- BEFESTIGUNGSPUNKTE DER RUCKWANDHALTER INNEN
- LES POINTS PRISE (CROCHET) DE TAILLE DERRIERE



I
16

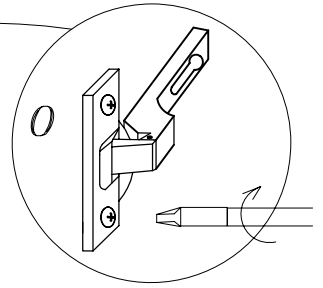
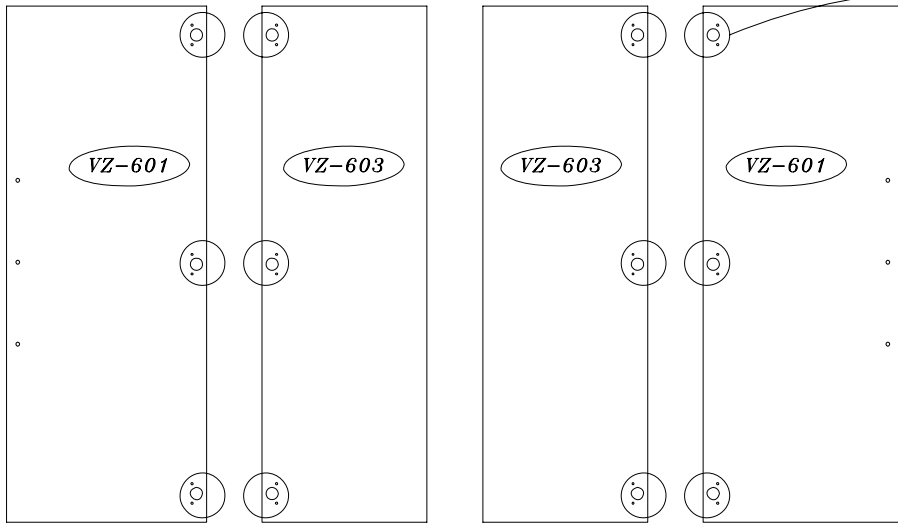

# 10

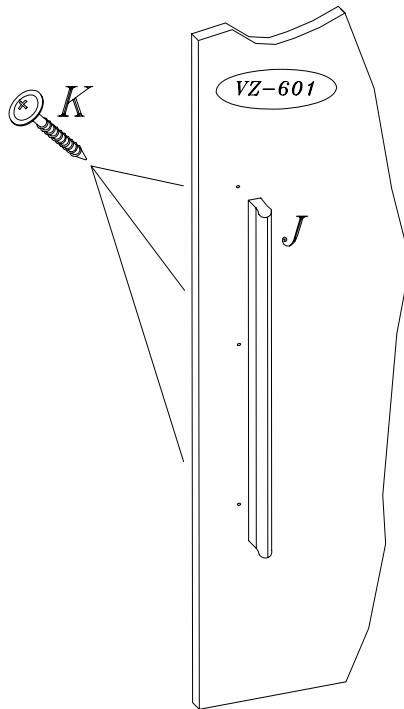

	0
	12

# 11

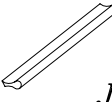

	4.0X30
J	
2	K
	6

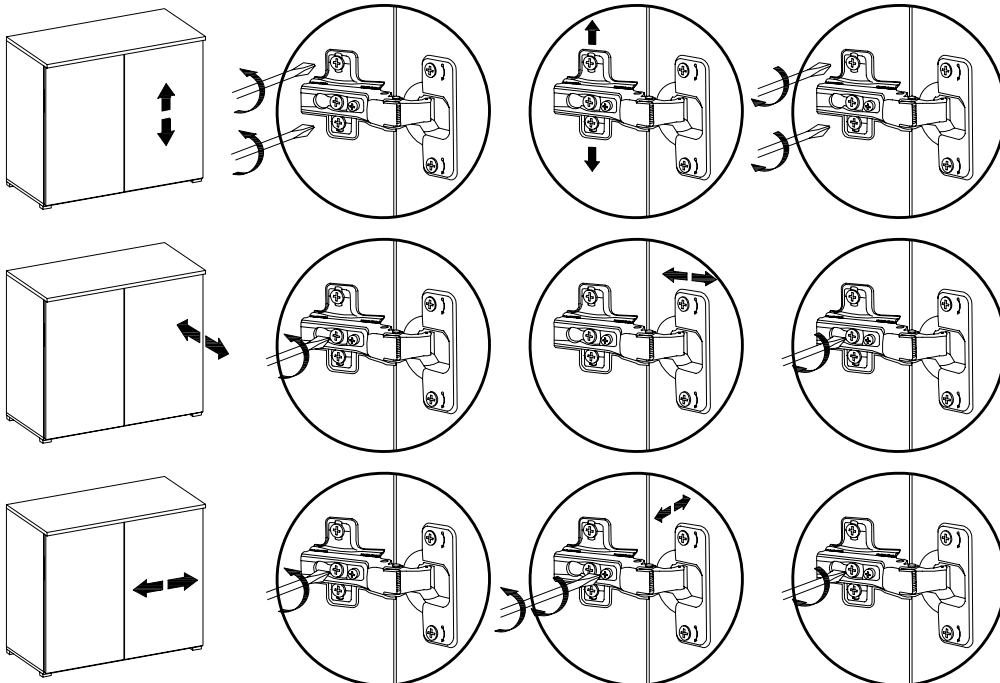

# SERVICEKARTE

Modellname:  
**VERA-20**

Artikel-Nr.:  
...

Type: (falls vorhanden)



















Farb-Nr.: (falls vorhanden)

Liebe Kundin, lieber Kunde,

obwohl wir unsere Moebel vor der Auslieferung einer eingehenden Endkontrolle unterziehen, kann statt denn es vorkommen, dass einmal ein Zubehoerteil fehlt oder dass ein Teil waehrend des Transportes beschaedigt wird. **Senden Sie den Artikel in so einem Fall bitte nicht zurueck, sondern fordern Sie einfach Ersatz fuer das fehlende bzw. beschaedigte Teil bei unserer **Kunden - Hotline** an. Die Telefonnummer finden Sie auf den **Serviceseiten** im aktuellen Katalog.**

Bitte nennen Sie bei der Ersatzteilbestellung **Modellnamen, Artikelnummer, Type und Farbnummer** des Moebelsueckes sowie die benoetigten **Ersatzteilnummern /- bezeichnungen**, wie sie in dieser Anleitung angegeben sind.

Wir werden ihre Anforderung sofort bearbeiten und Ihnen das Ersatzteil umgehend zusenden.

 A	 B	 D	 E	 G	6.3X11  H	 I	 J	4.0X30  K
16	16	8	10	12	12	16	2	6
 N	 O	 P	3.0X13  R	3.5X13  S	 U			
12	12	2	2	48	1			
 W	 X	4.0X13  Z						
20	12	16						

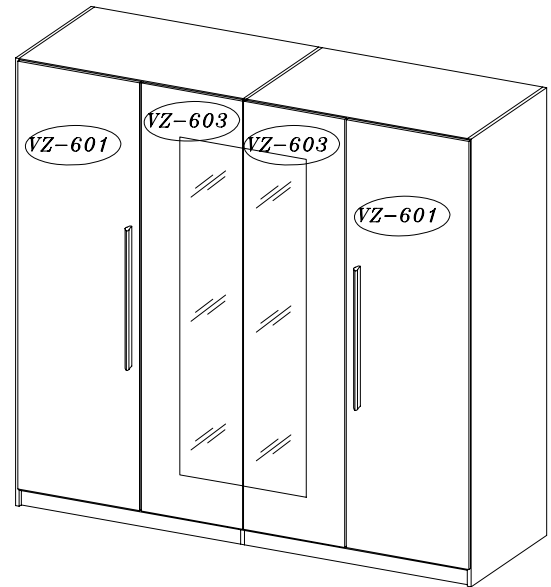
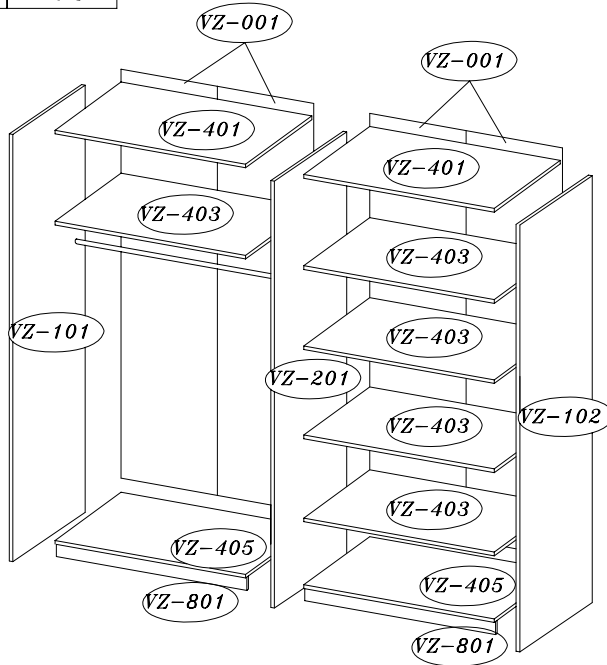

Hier koennen Sie die Schrauben zur besseren Identifizierung nachmessen (alle Massangaben in mm).

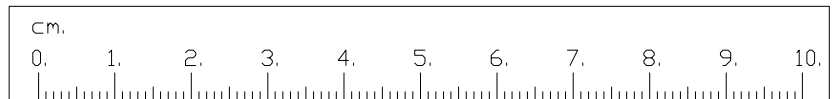

Bitte fuellen die anstatt dieses Servicekarte sorgfaeltig aus, damit Sie alle noetigen Daten bei Ihrer Ersatzteilbestellung zur Hand haben. Die Telefonnummer der Bestellannahme finden Sie in Ihrem aktuellen Katalog.

Modellname .....  
 Artikel - Nr.: .....  
 Type .....  
 Farb - Nr.: .....  
 Kundennummer: .....  
 Name: .....  
 Strasse: ..... Haus - Nr.: .....  
 PLZ ..... Ort: .....  
 Rechnungsdatum: .....

Tel. fur Ruckfragen: .....

Grund der Ersatzteilanforderung: .....

Benoetigte Teile:

Teile - Nr.	Bezeichnung	Anzahl



# VERA 26

Instrukcija montažu  
Montageanleitung  
Instructions D'assemblage  
Assembly instructions

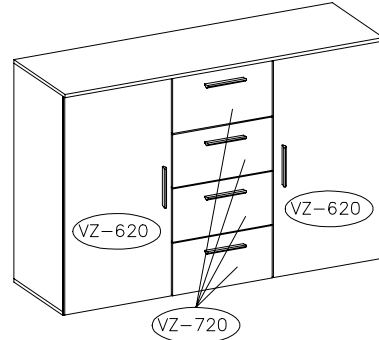
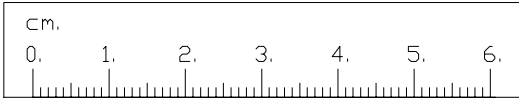
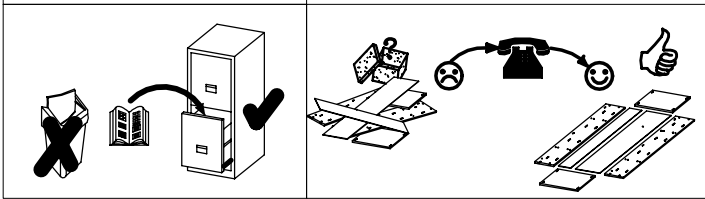
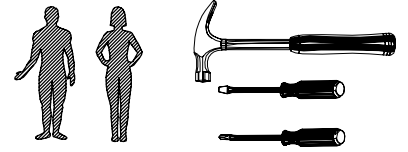

					M4.0X8
A	B	C	D	E	
16	16	16	16	8	
F	G	H	I	J	I1
8	12	8	16	8	1
K	L	M	N	O	X
1	6	4	8	6	4

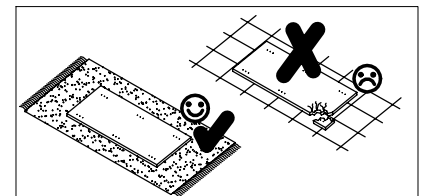
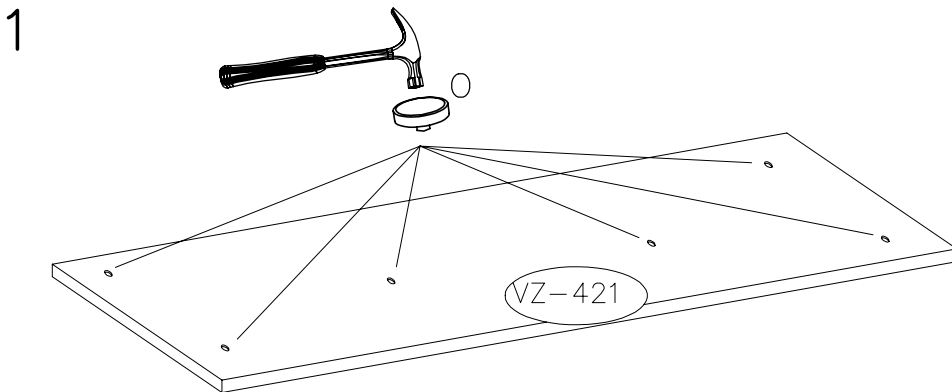
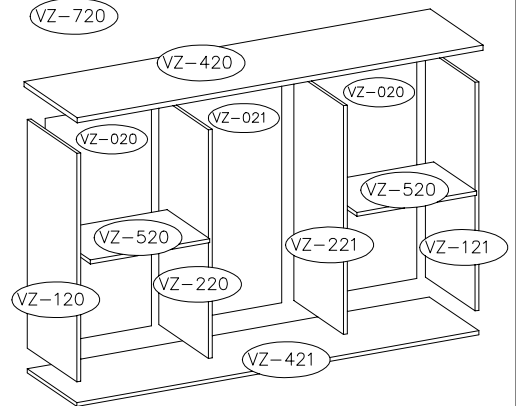

O	A
6	16

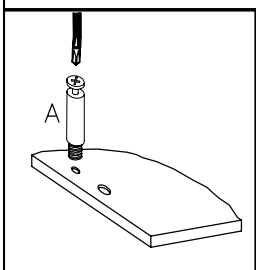
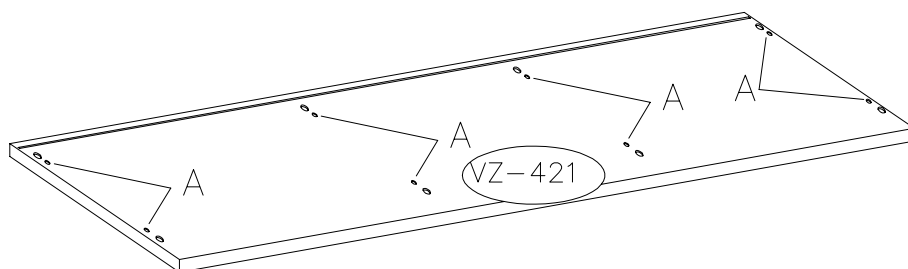
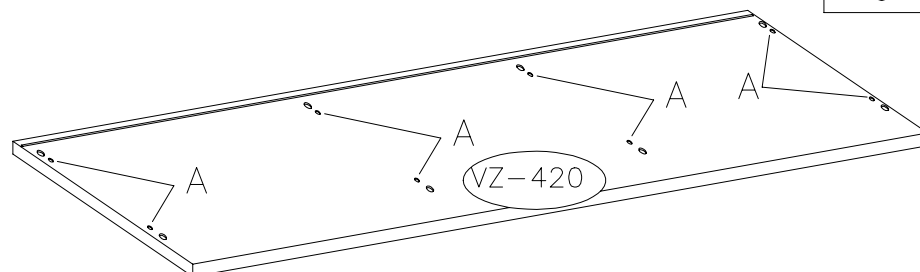

2

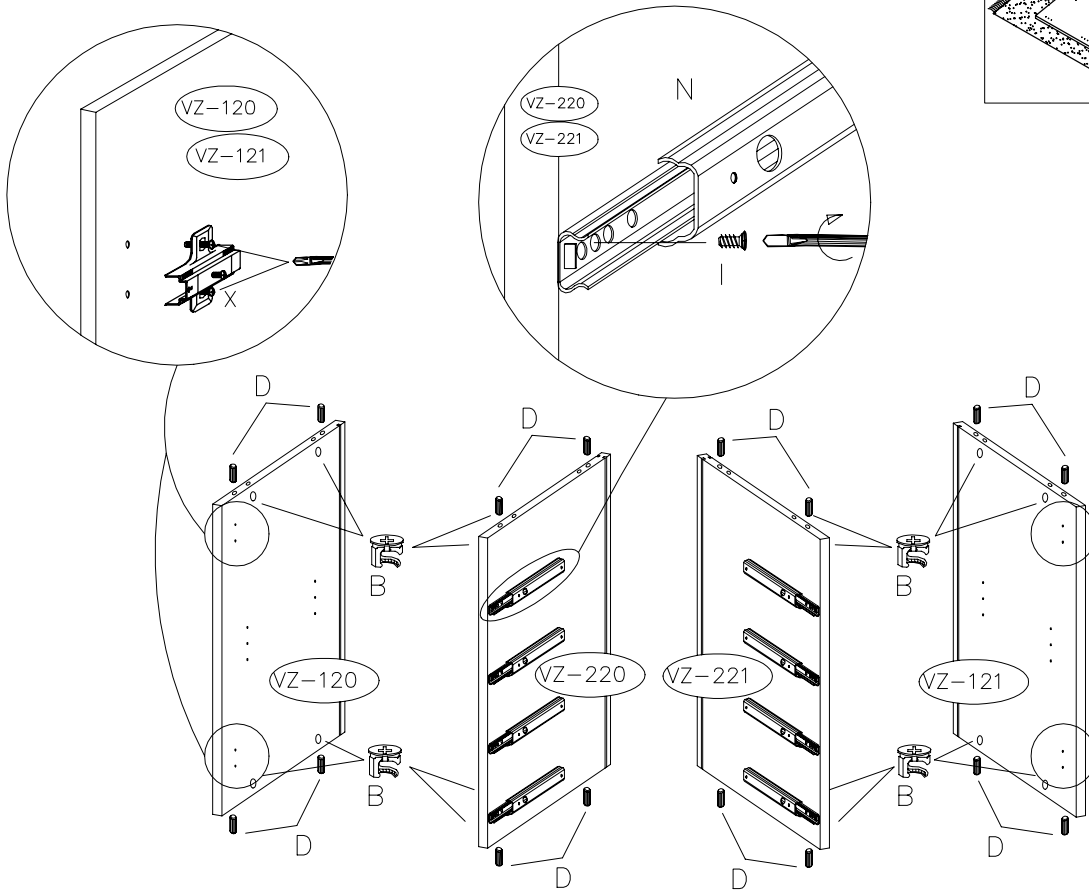
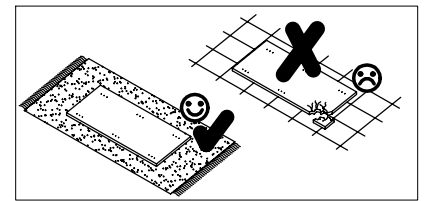

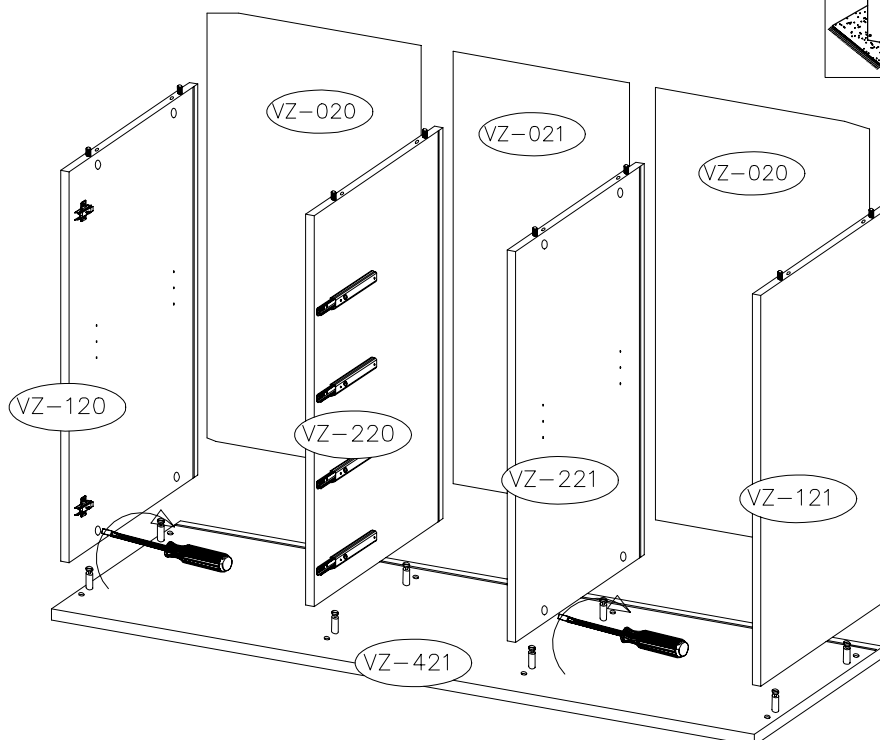
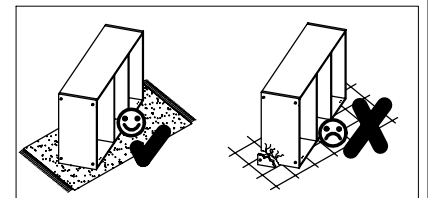

		6.0X11 		
B	D	I	N	X
16	16	16	8	4

3



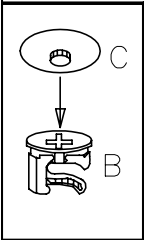
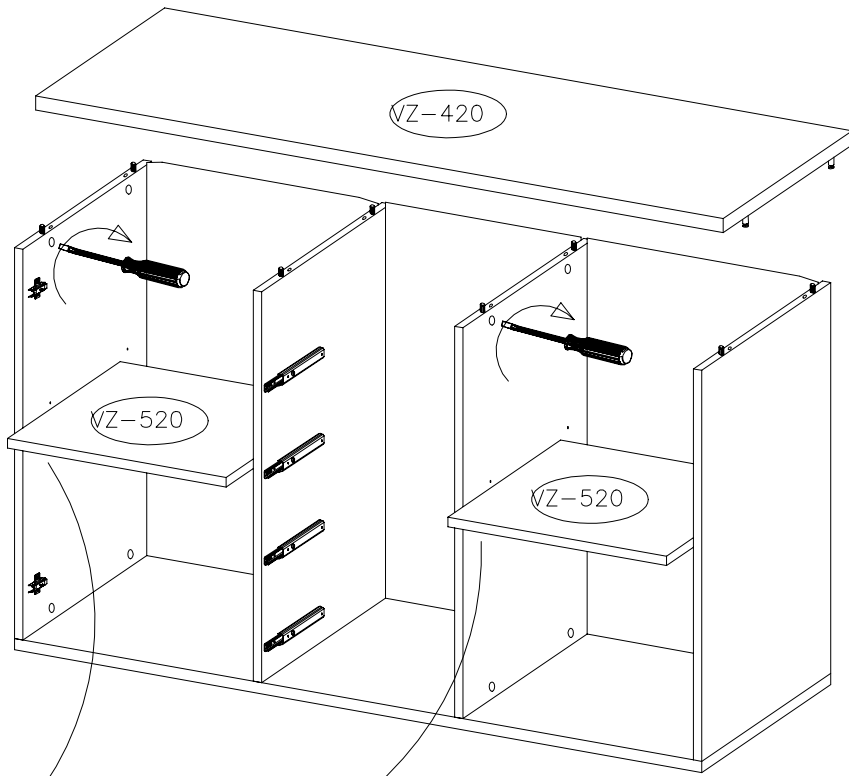

4

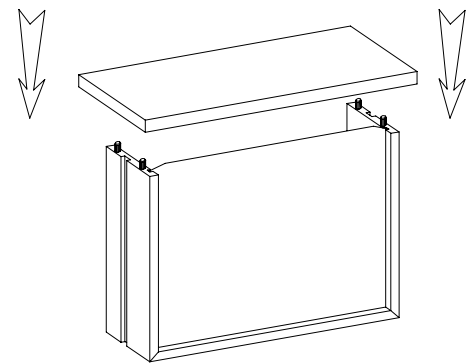
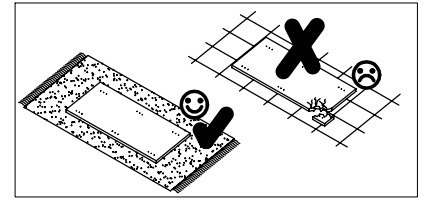
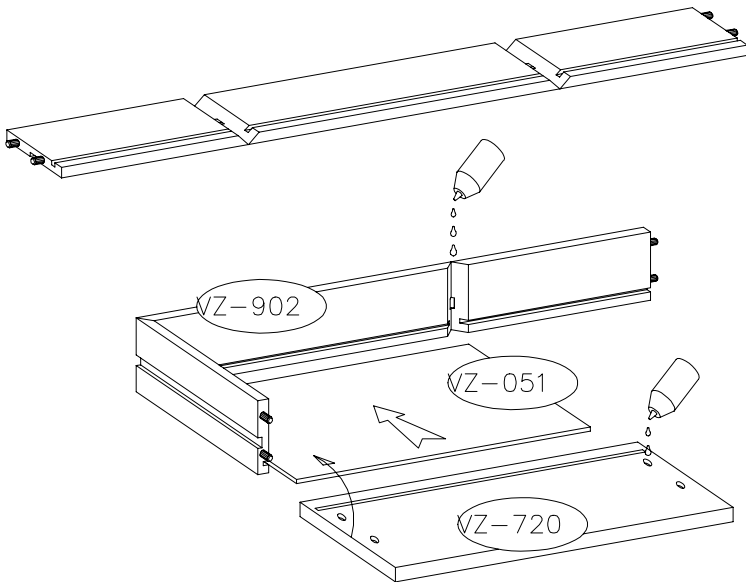

	
F	C
8	16

5



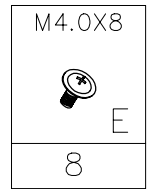
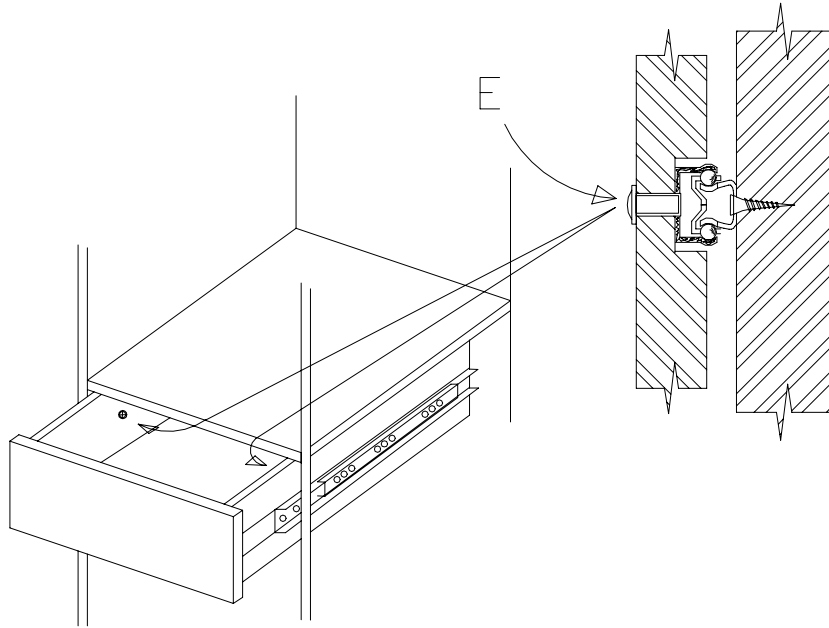

K
1

6

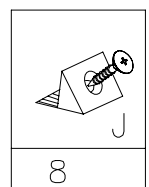
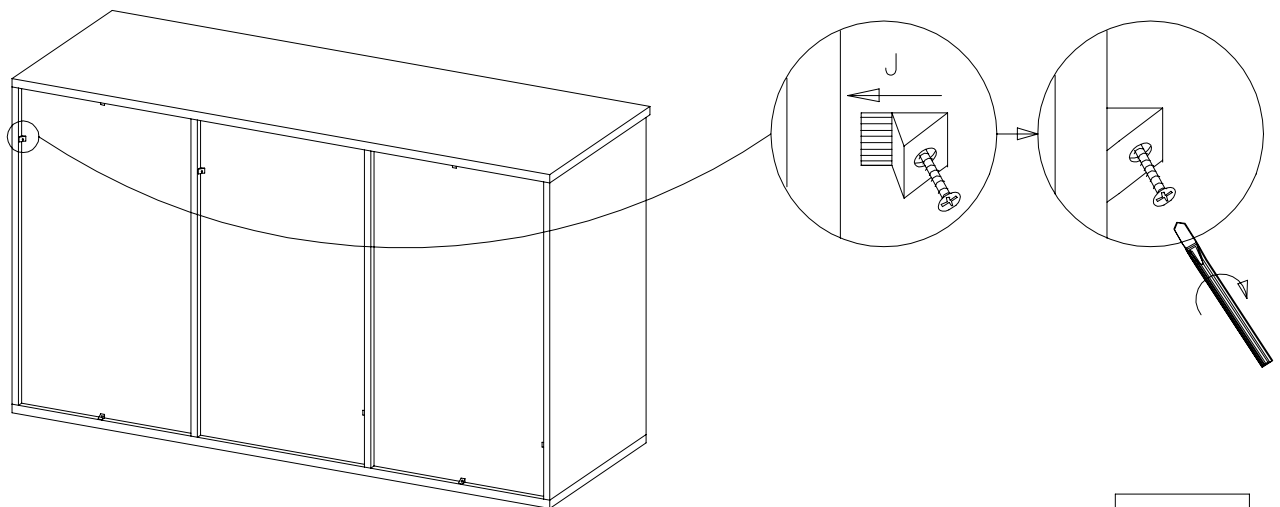

7



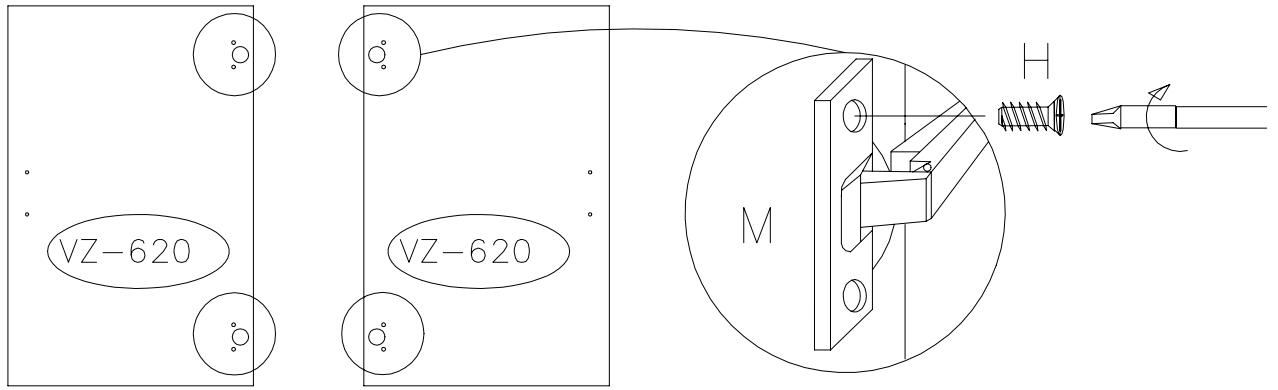

8

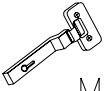

6.3X13  H	 M
8	4

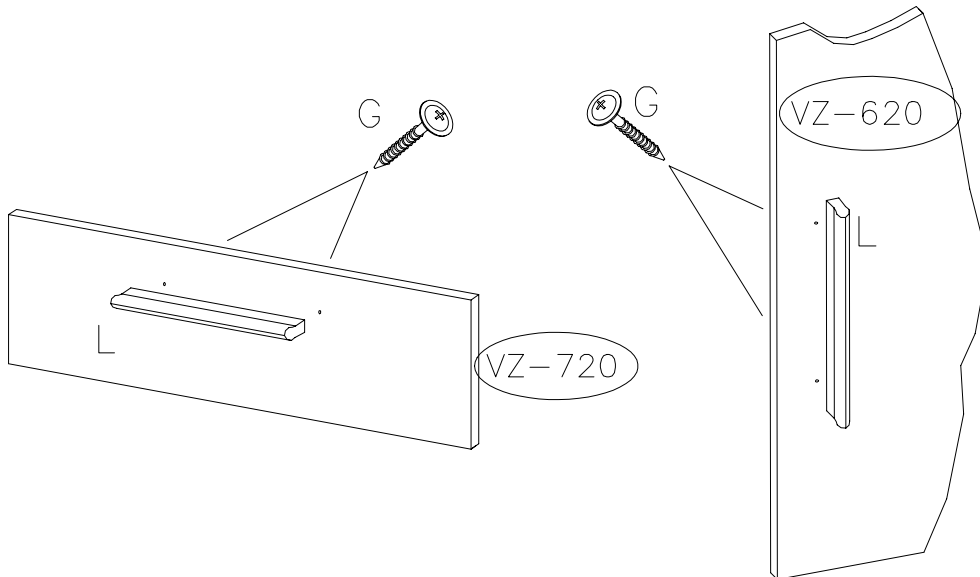
9

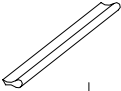

4.0X30  G
12
 L
6

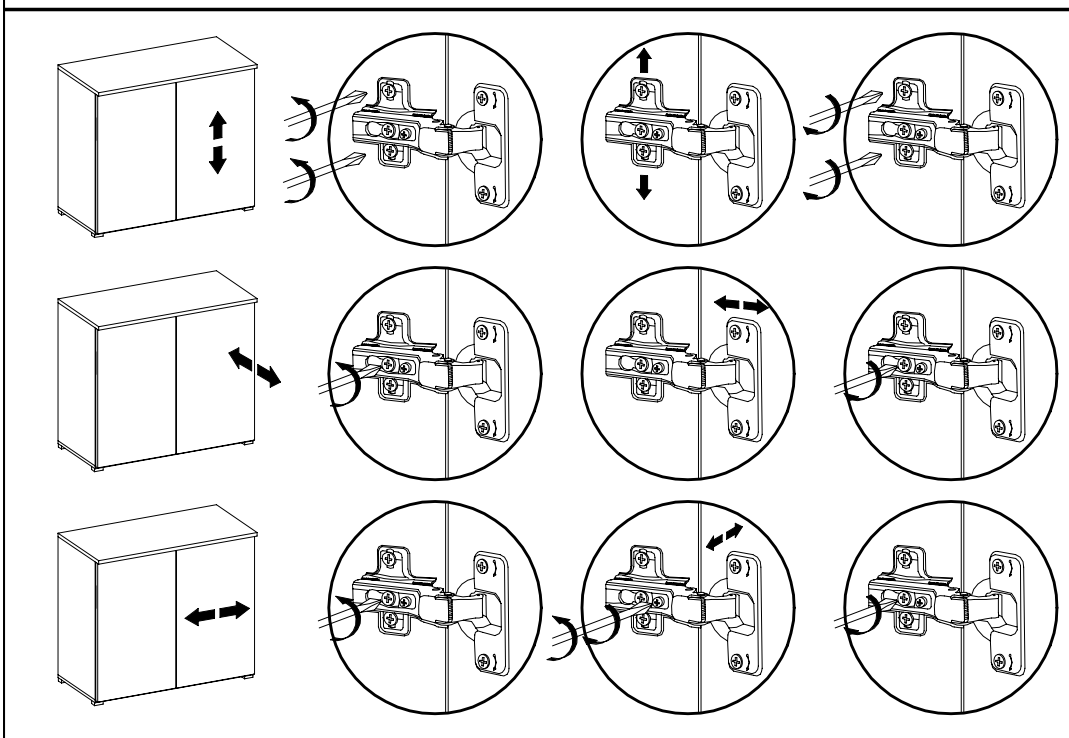



1

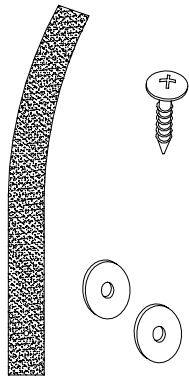

<b>Uwaga • Upozornini • Achtung • Attention • Caution • Figyelem</b> <b>Attenzione • Opgelet • Внимание • Atentie • Upozornenie • Dikkat</b>	
PL	Mocowanie do ściany jest jednocześnie zabezpieczeniem przed przewróceniem – koniecznie zamontować!
CZ	Do některých druhů stěn koniečně použít speciální kotelk mociující. Montáž na stěnu slouží jako ochrana proti převrnutí – bezpodmínečně umístěte! U některých typů stěn může být zapotřebí speciální hmoždinka!
D	Wandbefestigung dient als Kippschutz – unbedingt anbringen! Bei einigen Wandtypen kann ein Spezialdübel erforderlich sein!
GB	The wall fastening serves to prevent tipping – be absolutely sure to mount it! For certain wall types, a special wall plug may be necessary!
FR	La fixation murale sert de protection contre le basculement – à installer impérativement ! Pour certains types de murs il faut des chevilles spéciales !
NL	Bevestiging aan de muur dient als kantelbescherming – zeker en vast bevestigen! Bij enkele muurtypen is een speciale plug misschien vereist!
IT	Il fissaggio alla parete serve da protezione anti-ribaltamento – attaccarlo assolutamente! Per alcune strutture di parete può essere necessario un tassello speciale!
HU	A termékét a falhoz kel rögzíténi, különben az felborulhat! Egyes fal típusoknál speciális tiplit kell használni!
RU	Обязательно установите крепление на стене во избежание опрокидывания! Для некоторых типов стен может потребо- ваться специальная дюбель!
RO	Sistemul de fixare la perete serve ca protecție la răsturnare – de montat obligatoriu! Pentru unele tipuri de pereți este posibil să fie necesar un diblu special!
SK	Upevnenie na stenu slúži ako ochrana proti prevráteniu – bezpodmienečne použite! Pre niektoré druhy stien môže byť potrebná špeciálna hmoždinka!
TR	Duvardaki sabitleme, devrilmeye karşı bir emniyet tedbiridir ve mutlaka monte edilmelidir! Bazı duvar tiplerinde bunun için özel bir dübel gerekli olabilir!

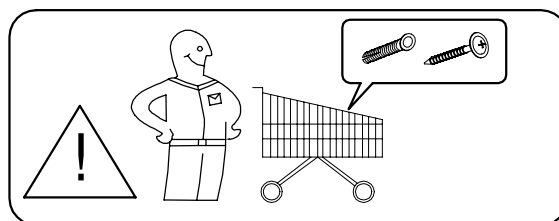
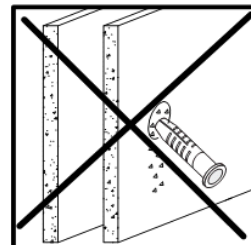
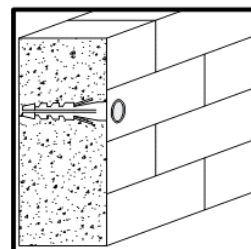

2a

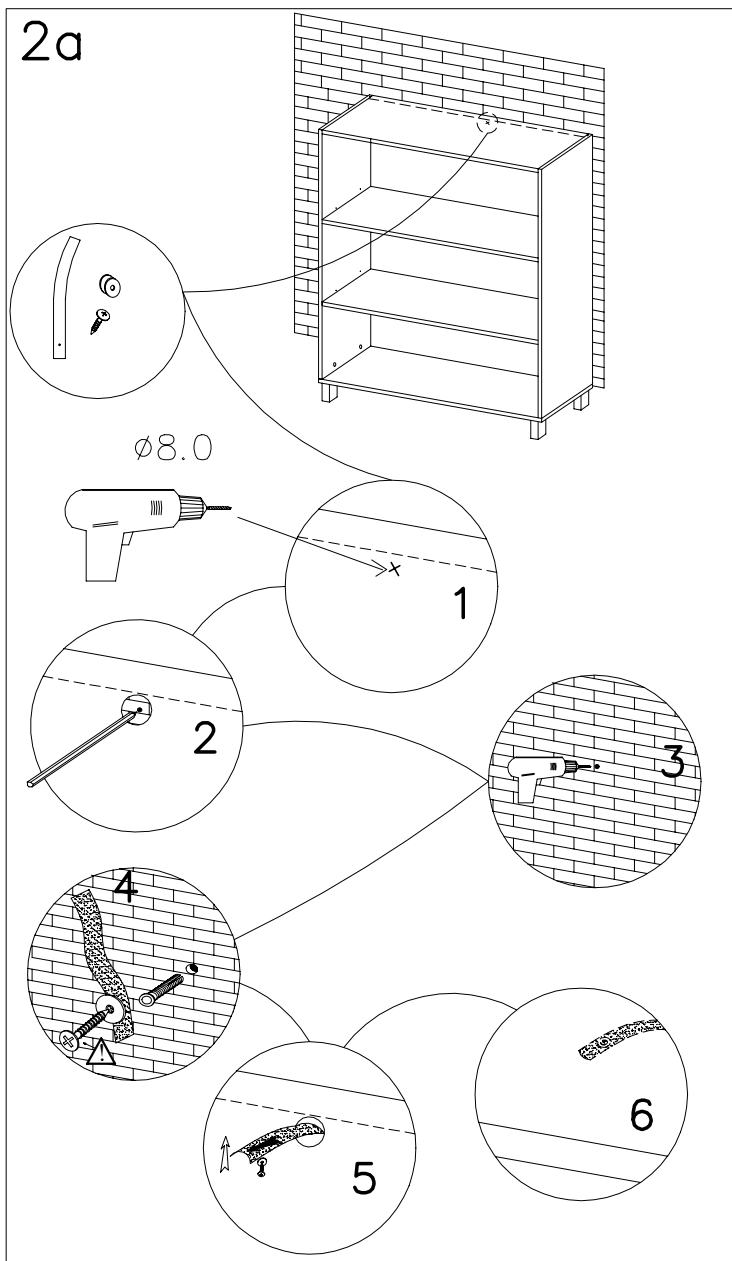

2b

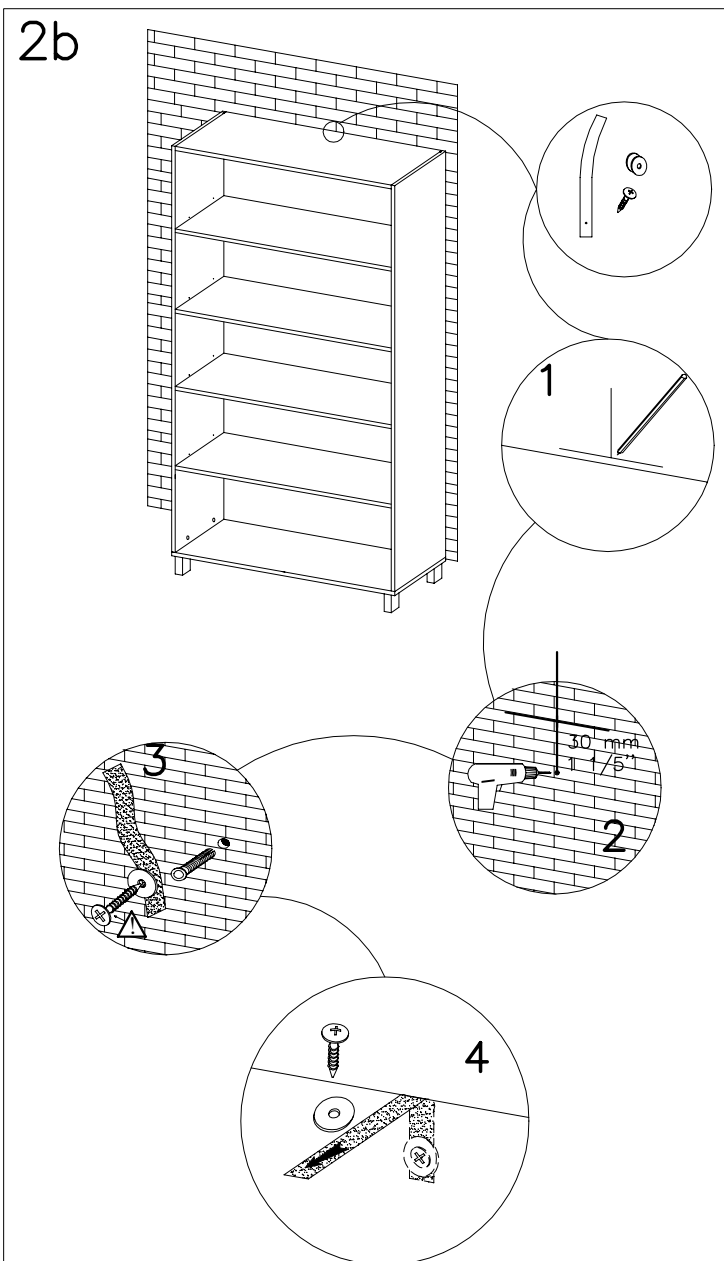



# VERA

## 30/31/32 51/52

Instrukcja montażu  
Montageanleitung  
Instructions D'assemblage  
Assembly instructions

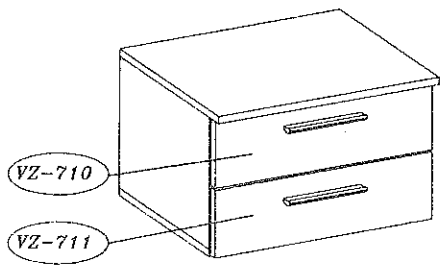
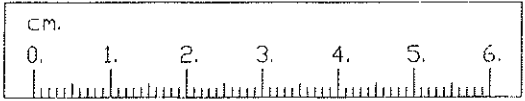
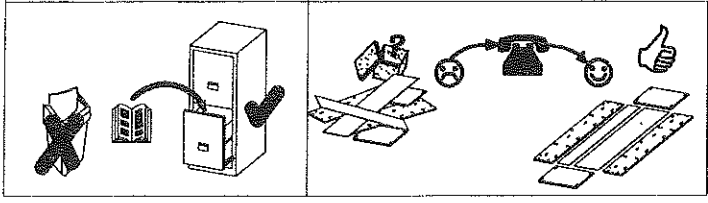
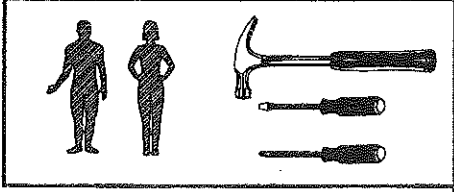

				M4.0X8	6.0X11
A	B	C	D	E	F
16	16	8	16	8	16
4.0X30					
G	H	I	J	K	
8	8	2	4	8	

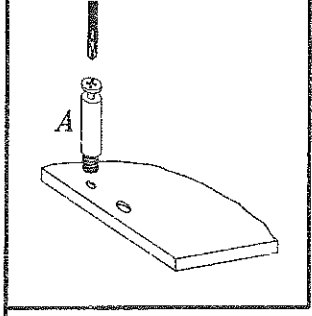
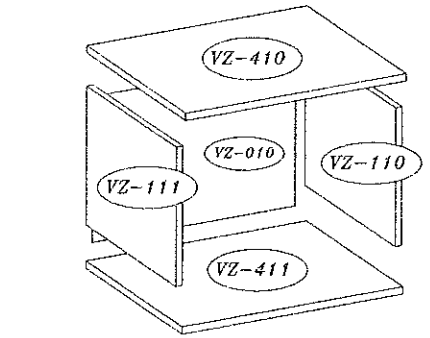

x2

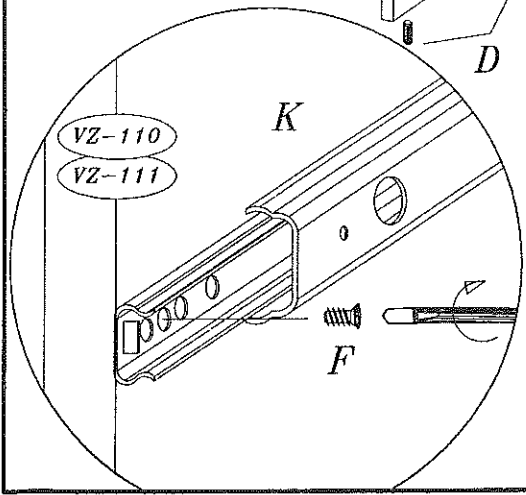
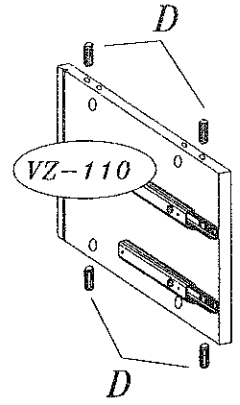
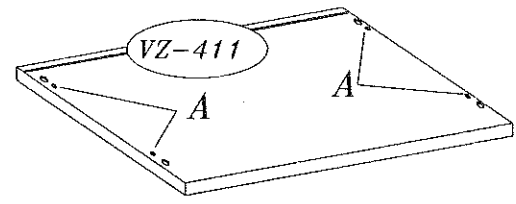
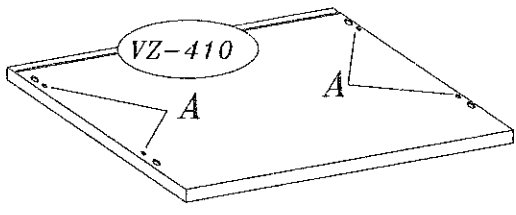
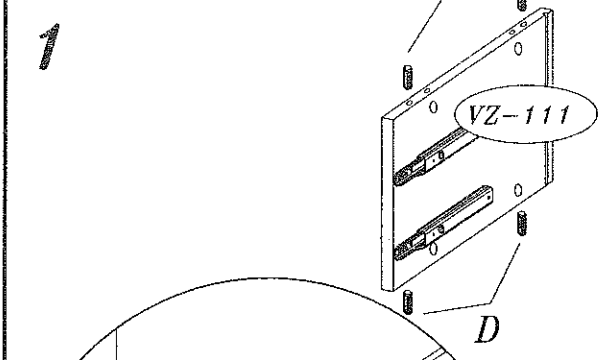
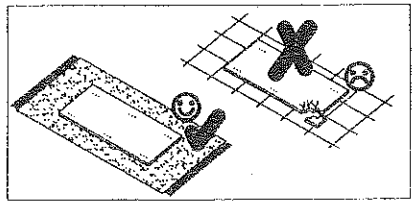
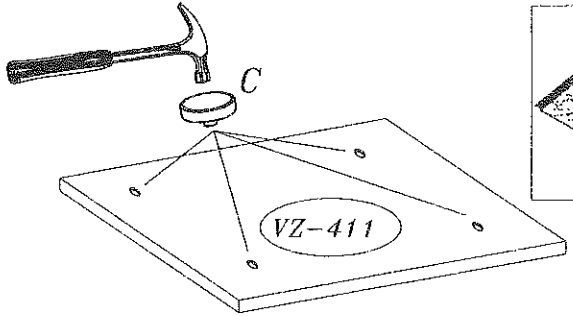

			6.0X11	
A	C	D	F	K
16	8	16	16	8

2

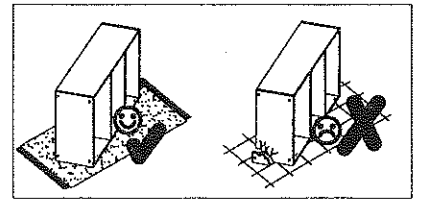

x2

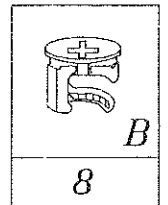
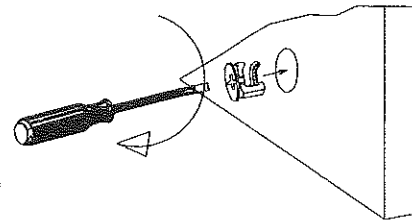
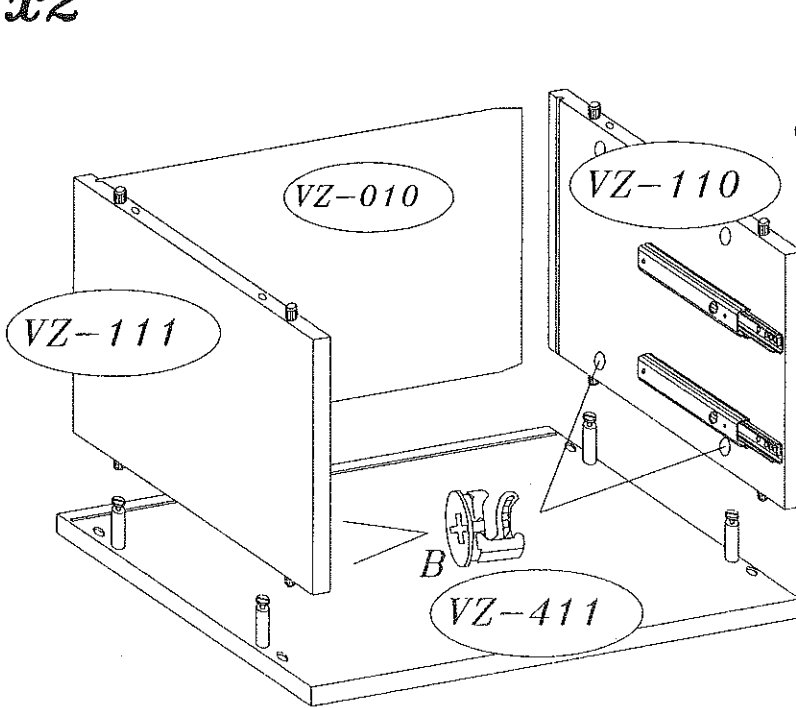

3

x2

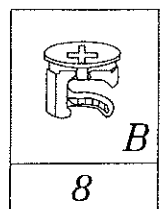
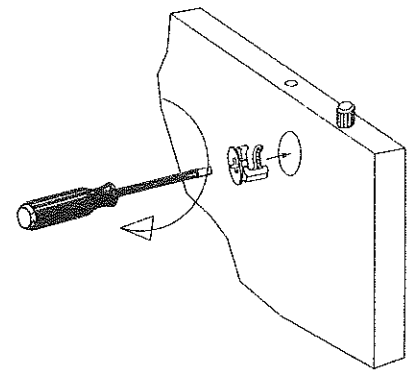
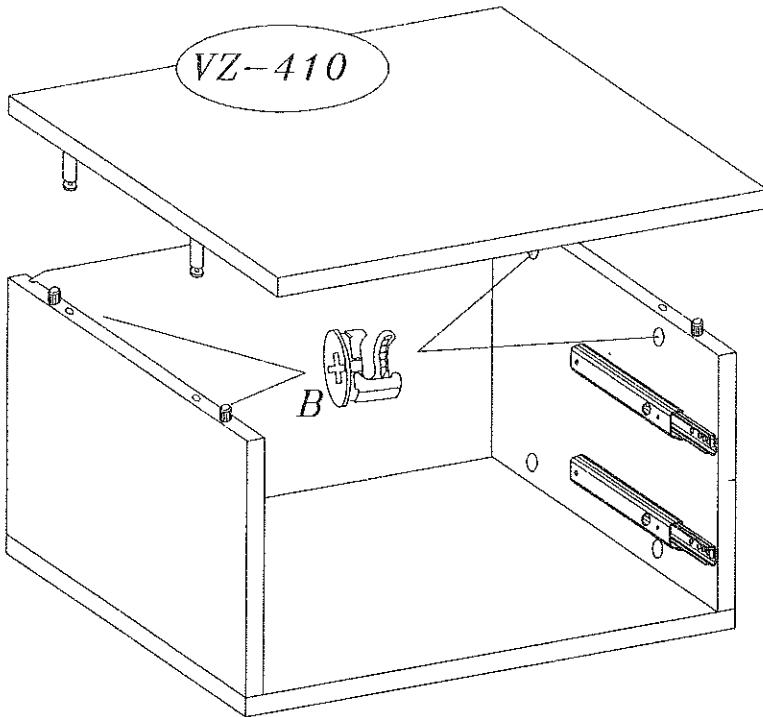
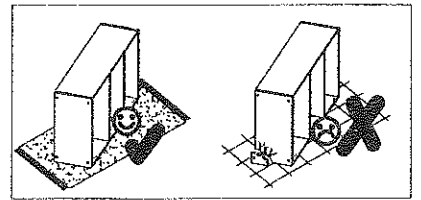

# SERVICEKARTE

Modellname:

**VERA-30/31/32 - 51/52**

Artikel-Nr.:

...

Type: (falls vorhanden)









Farb-Nr.: (falls vorhanden)

Liebe Kundin, lieber Kunde,

obwohl wir unsere Moebel vor der Auslieferung einer eingehenden Endkontrolle unterziehen, kann stattdessen es vorkommen, dass einmal ein Zubehoerteil fehlt oder dass ein Teil waehrend des Transportes beschaedigt wird. **Senden Sie den Artikel in so einem Fall bitte nicht zurueck, sondern fordern Sie einfach Ersatz fuer das fehlende bzw. beschaedigte Teil bei unserer Kunden - Hotline an.** Die Telefonnummer finden Sie auf den **Serviceseiten** im aktuellen Katalog.

Bitte nennen Sie bei der Ersatzteilbestellung **Modellnamen, Artikelnummer, Type und Farbnummer** des Moebelsueckes sowie die benoetigten **Ersatzteilnummern /- bezeichnungen**, wie sie in dieser Anleitung angegeben sind.

Wir werden ihre Anforderung sofort bearbeiten und Ihnen das Ersatzteil umgehend zusenden.

				M4.0X8	6.0X11
A	B	C	D	E	F
16	16	8	16	8	16
4.0X30					
G	H	I	J	K	
8	8	2	4	8	

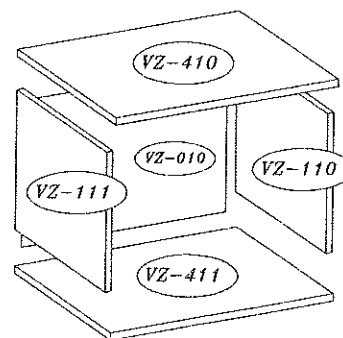
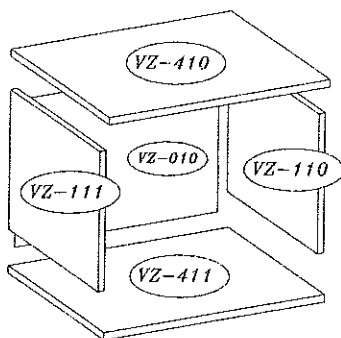
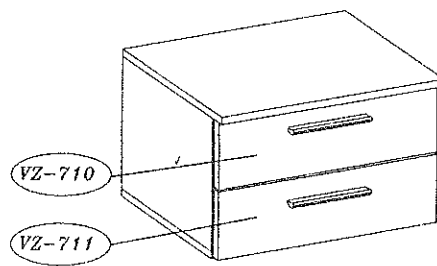
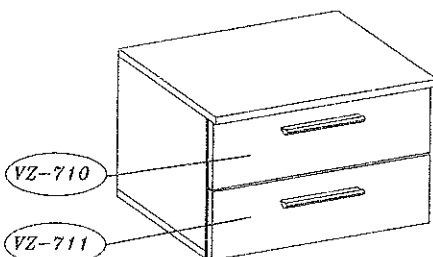
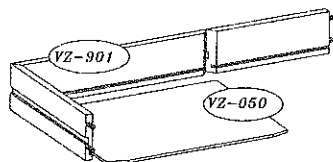

Hier koennen Sie die Schrauben zur besseren Identifizierung nachmessen (alle Massangaben in mm).

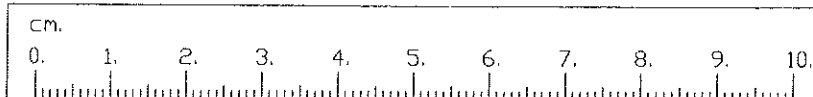

Bitte fuellen die anstatt dieses Servicekarte sorgfaeltig aus, damit Sie alle noetigen Daten bei Ihrer Ersatzteilbestellung zur Hand haben. Die Telefonnummer der Bestellannahme finden Sie in Ihrem aktuellen Katalog.

Modellname .....

Tel. fuer Ruckfragen: .....

Artikel - Nr.: .....

Grund der Ersatzteilanforderung: .....

Type .....

Farb - Nr.: .....

Benotigte Teile:

Kundenummer: .....

Teile - Nr.	Bezeichnung	Anzahl

Name: .....

Strasse: ..... Haus - Nr.: .....

PLZ ..... Ort: .....

Rechnungsdatum: .....

