

MONTAGE HANDLEIDING

INSTRUCTIONS DE MONTAGE - ASSEMBLY INSTRUCTION - MONTAGE ANLEITUNG - STRUZIONI DI MONTAGGIO
 INSTRUÇÕES DE MONTAGEM - INSTRUCCIONES DE MONTAJE - MONTAŽU UPUTE

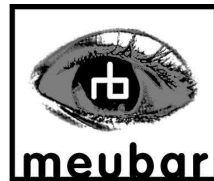

Young budget furniture

KENT K2

armoire 2 portes - 2 deurskast - wardrobe 2 doors

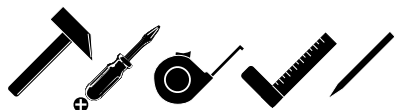
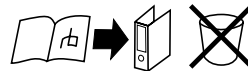

- | | | | |
|------------------------------------|------------------------------------|-------------------------------------|------------------------------------|
| A
G460086
8x30
4 | B
G460249
4 | C
G460252
4 | D
G470007
4x40
4 |
| E
G460265
4 | F
G440102
6 | G
G440107
6 | H
G460266
10 |
| I
G4608831
3 | J
G4608832
3 | K
G470013
3.5x16
12 | L
G4201605
2 |
| M
G460248
L 1083
1 | N
G4600781
7x50
6 | O
G4401258
6 | P
G4401256
6 |
| Q
G460246
2 | R
G460255
8 | S
G460223
6 | T
G470060
6.3x11
6 |
| U
G4750056
6 | V
G4750022
M6x35
2 | W
G460124
M4x23
2 | |

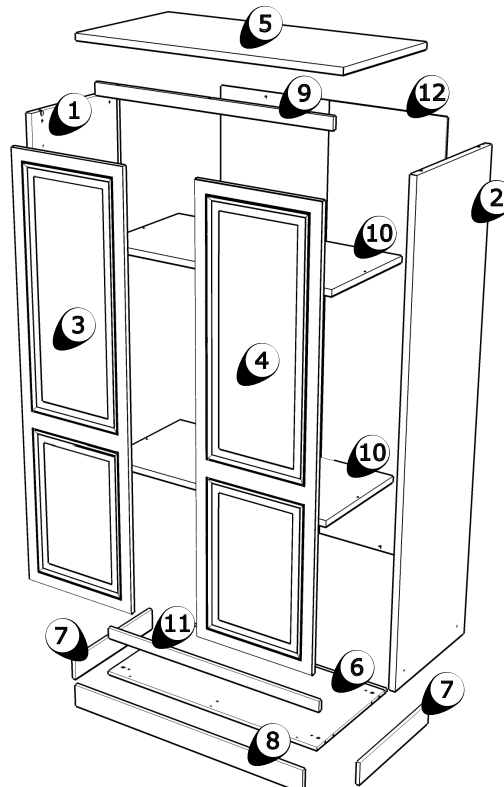
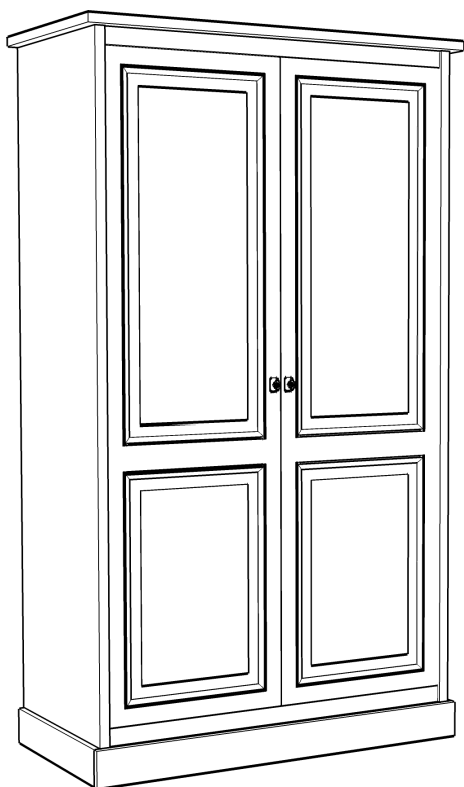
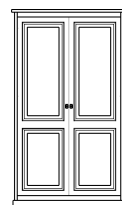

MONTAGE HANDLEIDING

INSTRUCTIONS DE MONTAGE - ASSEMBLY INSTRUCTION - MONTAGE ANLEITUNG - STRUZIONI DI MONTAGGIO
INSTRUÇÕES DE MONTAGEM - INSTRUCCIONES DE MONTAJE - MONTAŽU UPUTE

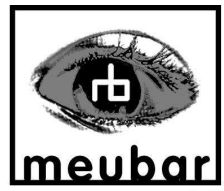

G4911132

KENT BB6

lit bébé - baby bed - baby bed

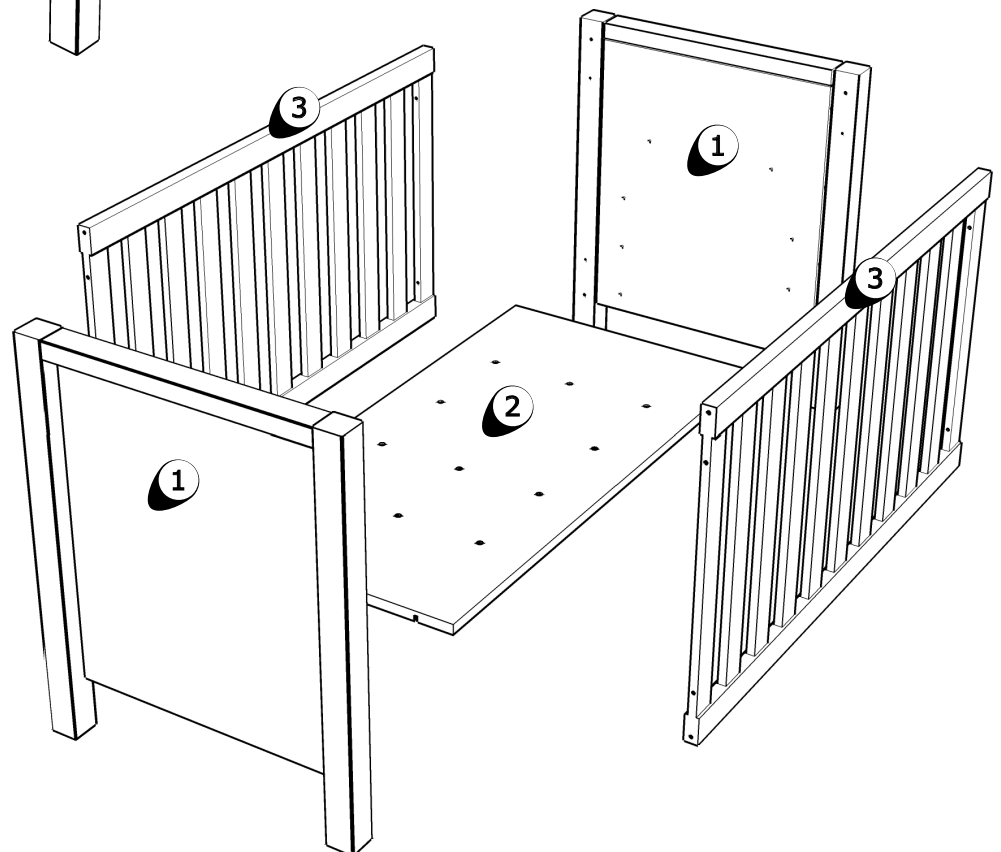
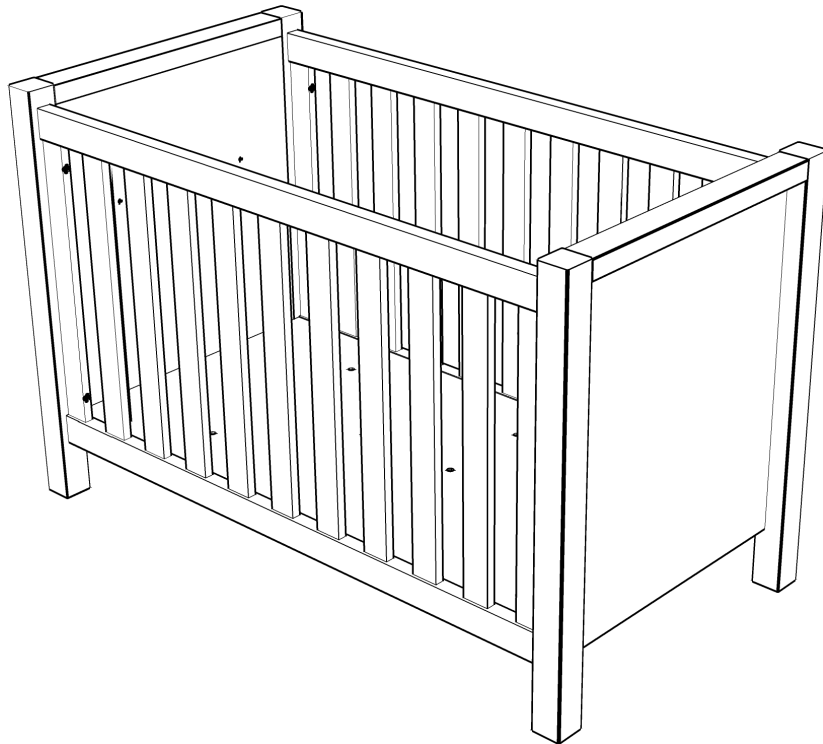
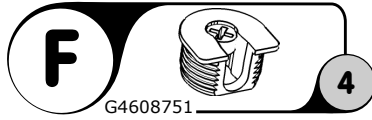
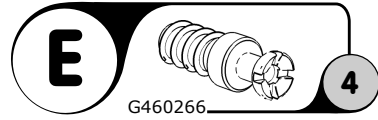
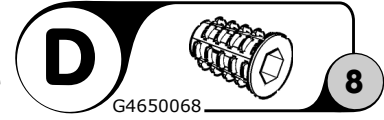
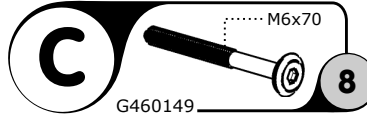
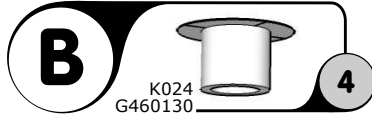
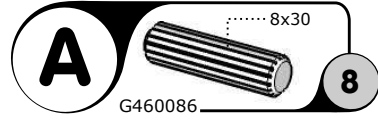
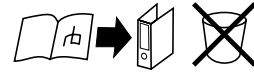

12-2018

MONTAGE HANDLEIDING

INSTRUCTIONS DE MONTAGE - ASSEMBLY INSTRUCTION - MONTAGE ANLEITUNG - STRUZIONI DI MONTAGGIO
 INSTRUÇÕES DE MONTAGEM - INSTRUCCIONES DE MONTAJE - MONTAŽU UPUTE

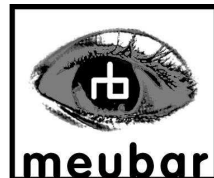

Young budget furniture

KENT KO6

commode - commode - commode

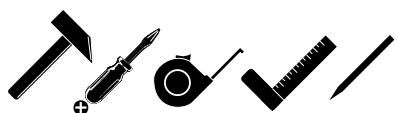
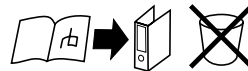

A G460086 8x30 12	B G460249 8	C G460252 8	D G470007 4x40 6
E G460265 4	F G440102 4	G G440107 4	H G460266 4
I G4608831 3	J G4608832 3	K G470013 3.5x16 12	L G460811 4
M G4201632 2	N G4600781 7x50 6	O G4401258 6	P G4401256 6
Q G4608717 12	R G430100 8	S G430101 8	T G460858 2
U G460859 2	V G470077 6.3x10.5 8	W G460124 M4x23 4	X G4201605 2

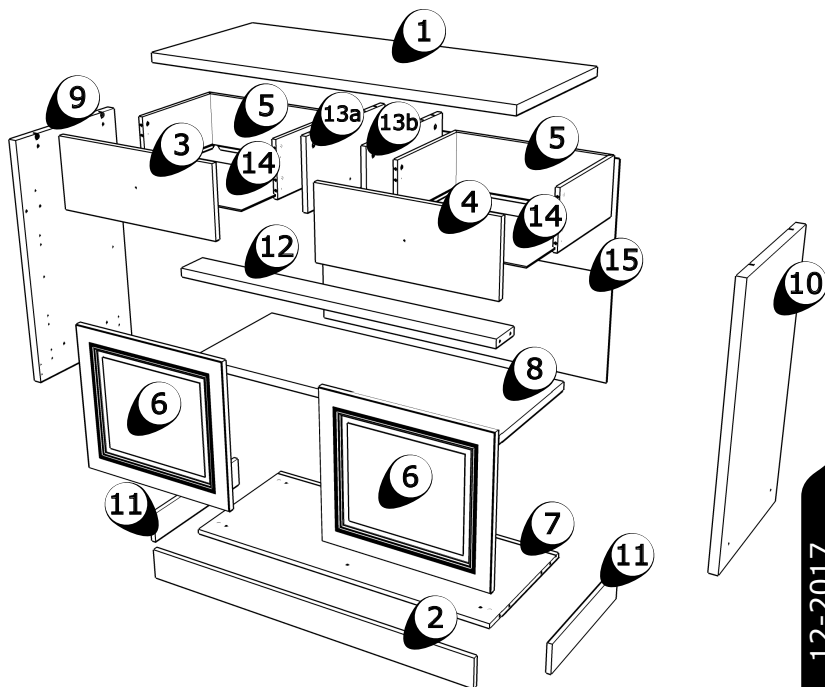
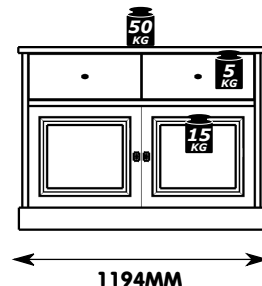
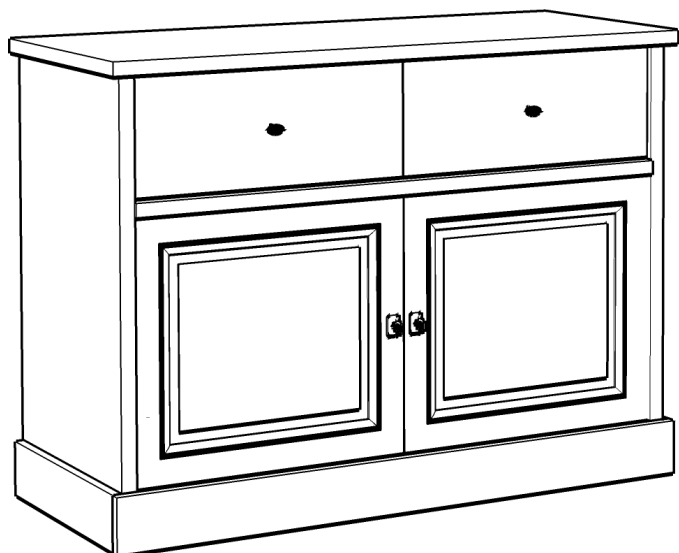

MONTAGE HANDLEIDING

INSTRUCTIONS DE MONTAGE - ASSEMBLY INSTRUCTION - MONTAGE ANLEITUNG - STRUZIONI DI MONTAGGIO
INSTRUÇÕES DE MONTAGEM - INSTRUCCIONES DE MONTAJE - MONTAŽU UPUTE

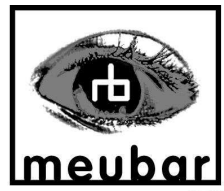

G4911134

KENT OPZETKO6

commode - commode - commode

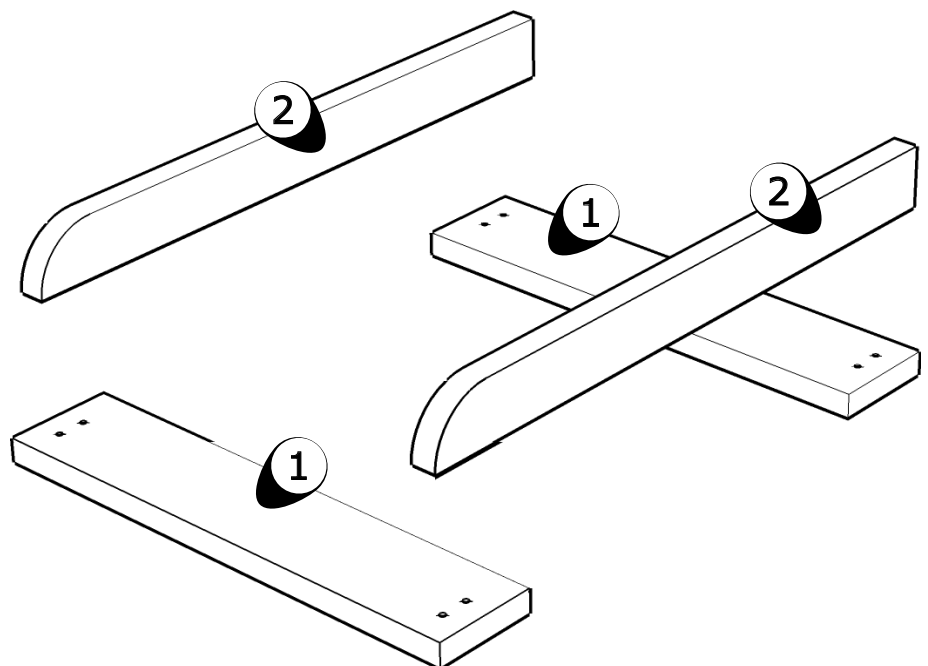
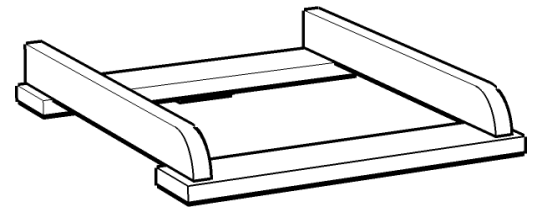
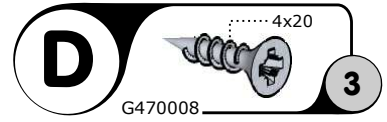
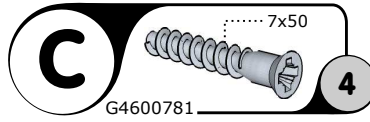
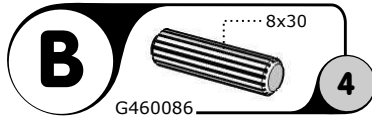
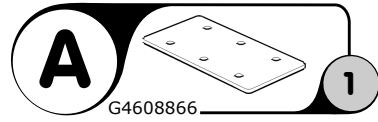
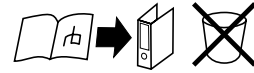

12-2018

1

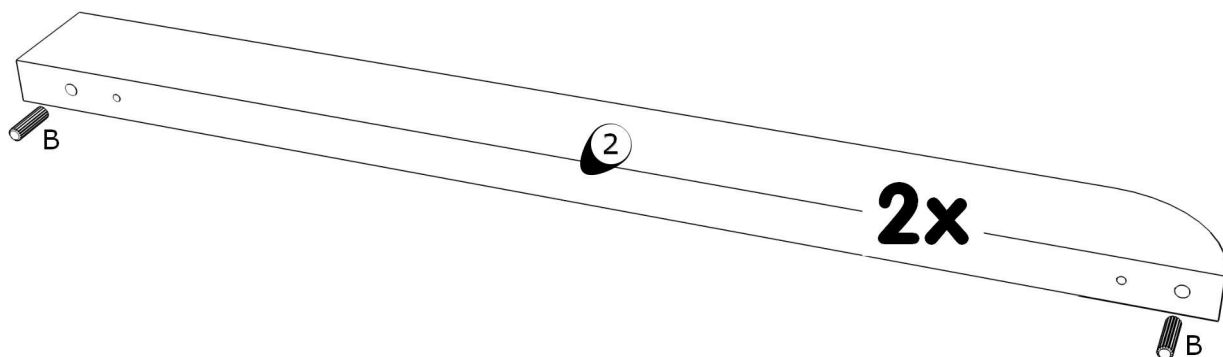

B

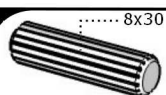

4

G460086

2

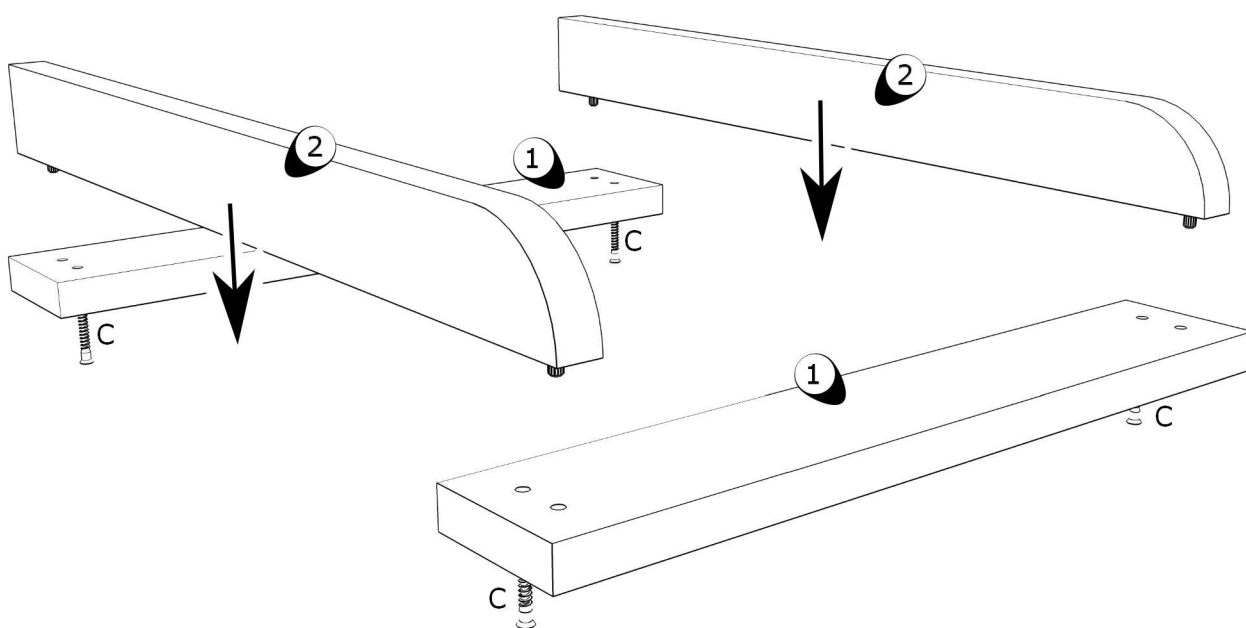

C



4

G4600781

3

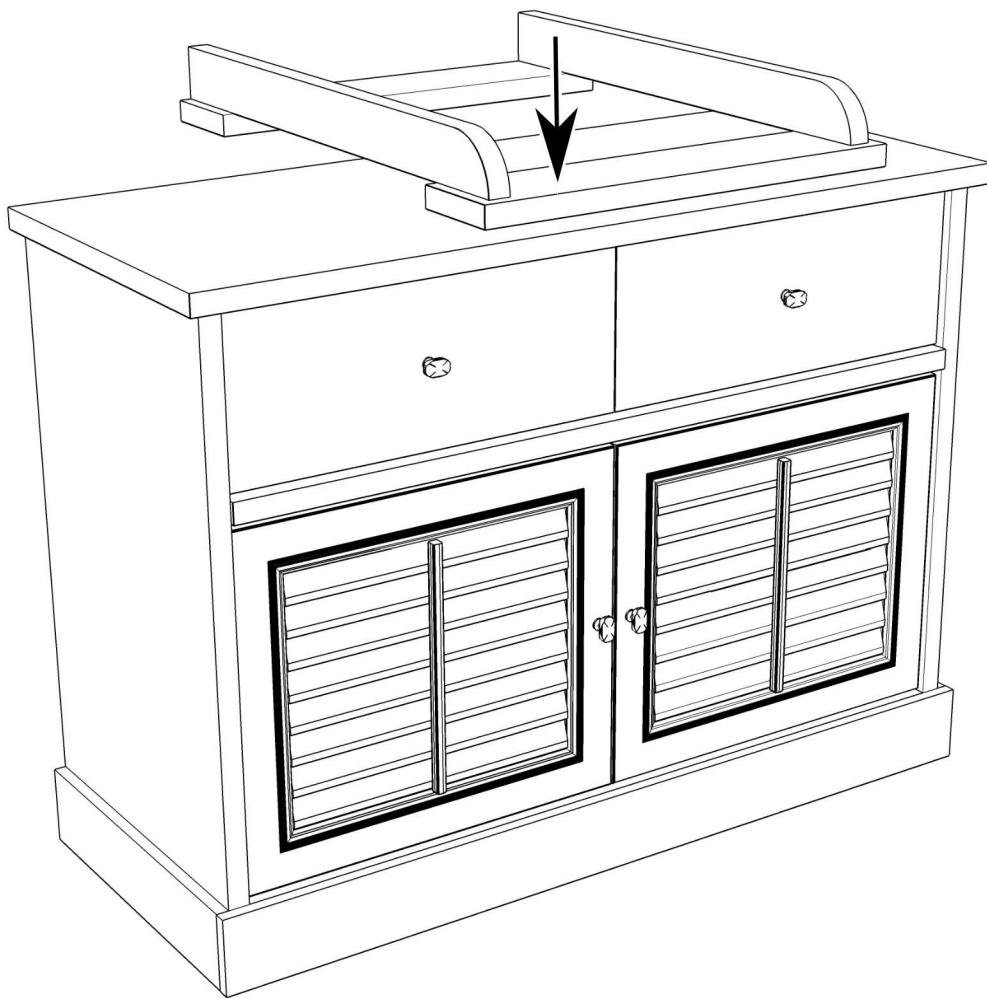

4

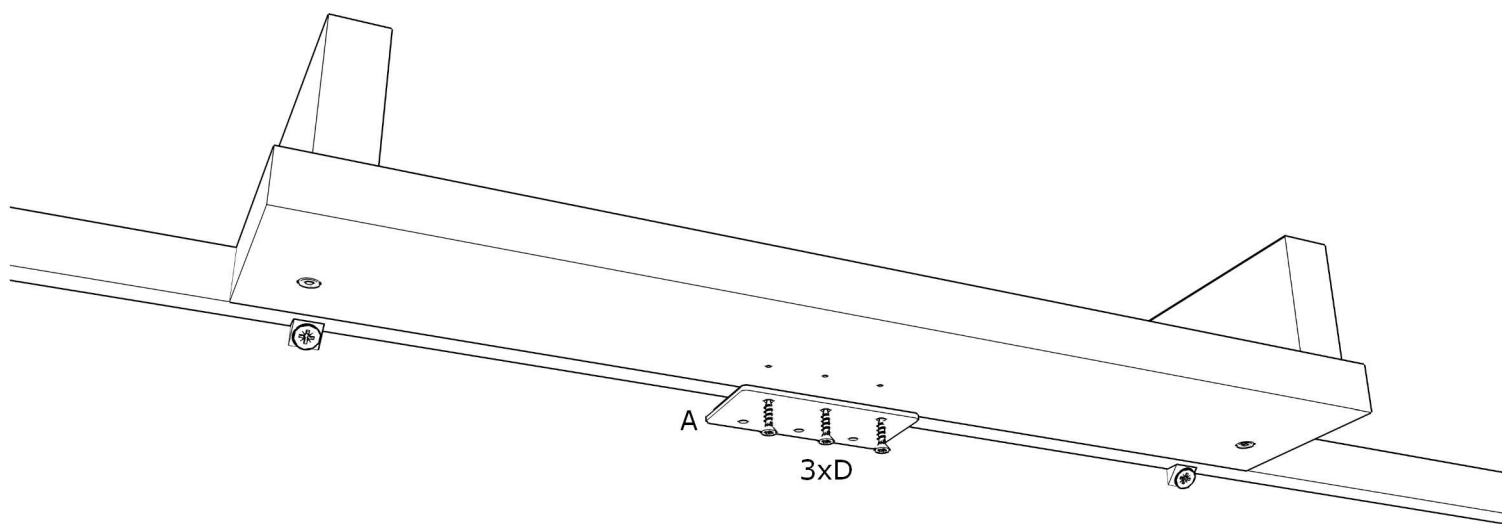

A

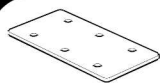

1

G4608866

D

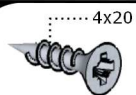

3

G470008

GEGEVENS AANKOPER

INFORMATIONS ACHETEUR - BUYER INFORMATION - KAUFER INFORMATIONEN

WINKEL

MAGASIN - SHOP - GESCHÄFT

PLAATS

LIEU - TOWN - ORT

AANKOOPDATUM

DATE DE L'ACHAT - DATE OF PURCHASE - KAUFDATUM

REFERENTIE

REFERENCE - REFERENCE - REFERENZ

KLEUR

COULEUR - COLOR - FARBE

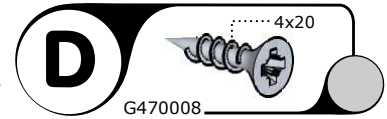
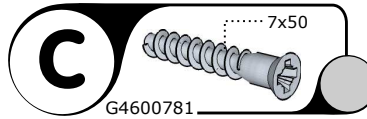
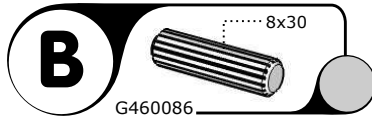
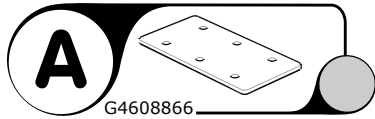
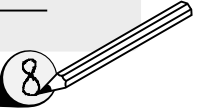

1 T5322478

2 T5322257

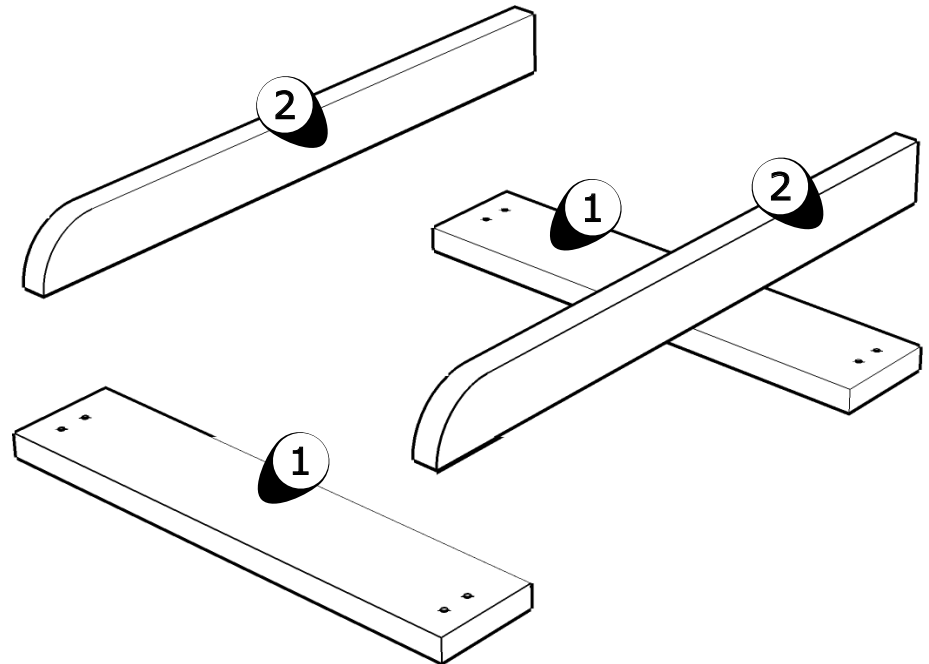

TOELICHTING EXPLICATIONS - EXPLANATION - ERKLÄRUNG

NL**ONDERHOUDSTIPS**

Oppervlakte kunststofdecor houtstructuur. Onderhoud: met lichte vochtige doek reinigen en hierna direct droog wrijven. De meubels zijn niet voor vochtige ruimten (bad, keuken etc.) bestemd. Vocht op het bovenblad direct opnemen. Montagetekening opbergen.

Het meubel moet door een vakkundig persoon, zoals in de handleiding staat beschreven worden gemonteerd. Door verkeerde montage kunnen gevaren ontstaan.

D**HINWEISE FÜR DIE PFLEGE**

Oberflächen Kunststoff-Dekor Holznachbildung. Pflegehinweis: Mit leicht feuchtem Tuch reinigen, sofort trocken nachwischen. Möbel nicht für Feuchträume geeignet (Bad, Küche etc.). Nässe auf Oberfläche unverzüglich wegwischen. Aufbauanleitung aufbewahren.

Das Möbel muss durch eine fachkundige Person entsprechend der Aufbauanleitung montiert werden. Bei fehlerhafter Montage kann es zu Gefahren kommen.

EN**ADVISE ON MAINTENANCE**

All surfaces in laminated wood colour finishes. Maintenance: clean with slightly moistened cloth, wipe dry immediately. Not suited for damp locations (kitchen, bathroom etc.). Wipe off wetness at once. Retain manual instruction.

The unit must be put together by a specialist according to the assembly instructions. Hazards may arise in case of incorrect assembly.

F**CONSEILS D' ENTRETIEN**

Panneaux de particules revêtus d'un film polymère. Entretien: utiliser un chiffon légèrement humide et repasser de suite avec un autre sec. Meuble inadapté aux pièces humides (bain, cuisine etc.). Toute trace de liquide est à essuyer immédiatement. Notice de montage à conserver.

Le meuble doit être monté par une personne spécialisée en la matière, conformément à l'instruction de montage. En cas d'erreur de montage, des dangers peuvent se manifester.

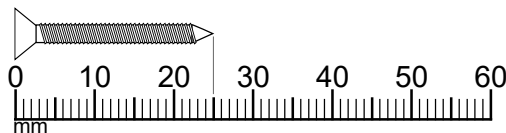
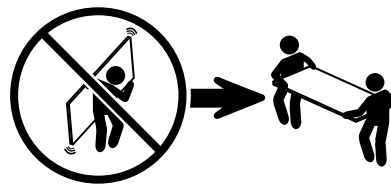
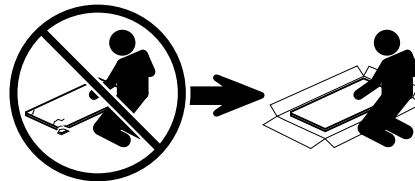
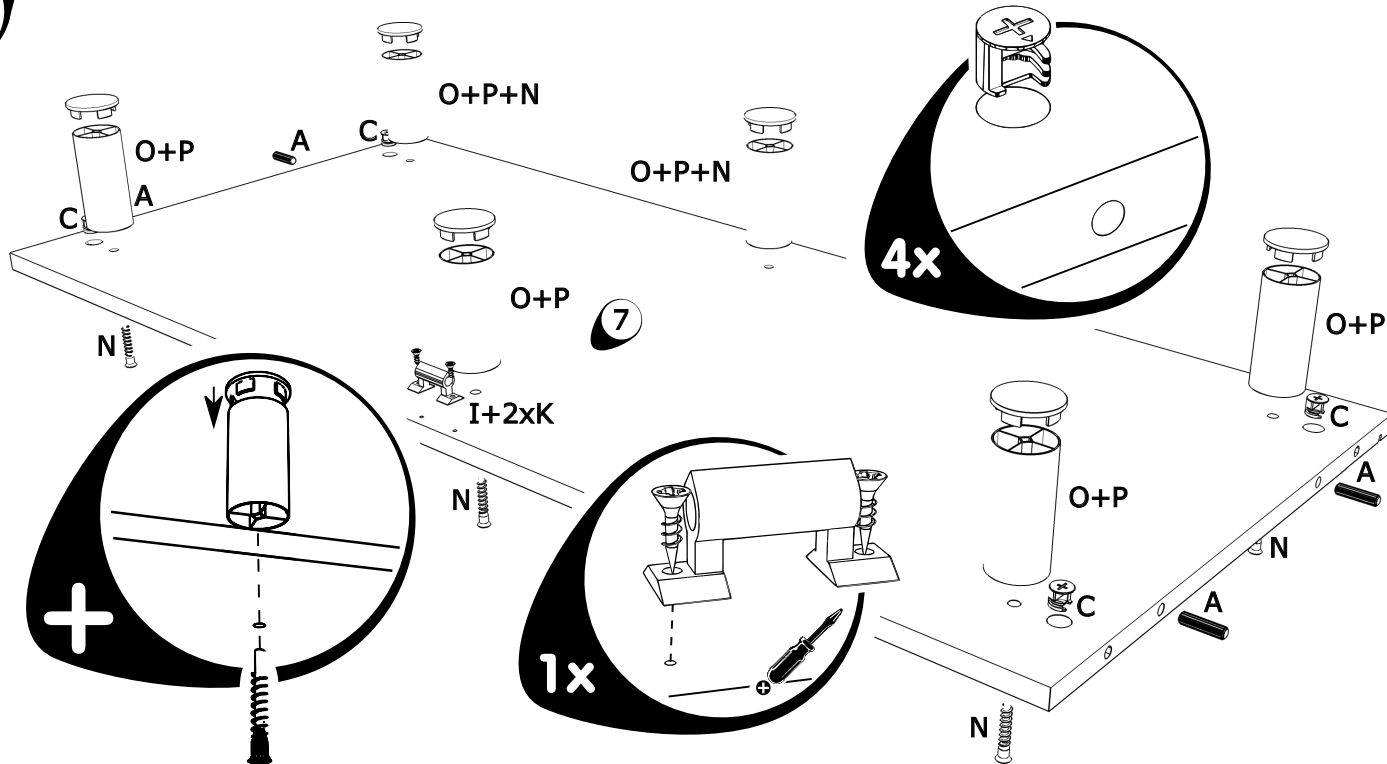
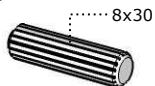
**1****A**

G460086

4**C**

G460252

4**I**

G4608831

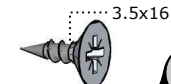
1**K**

G470013

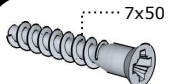
2**N**

G4600781

6**O**

G4401258

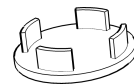
6**P**

G4401256

6

2

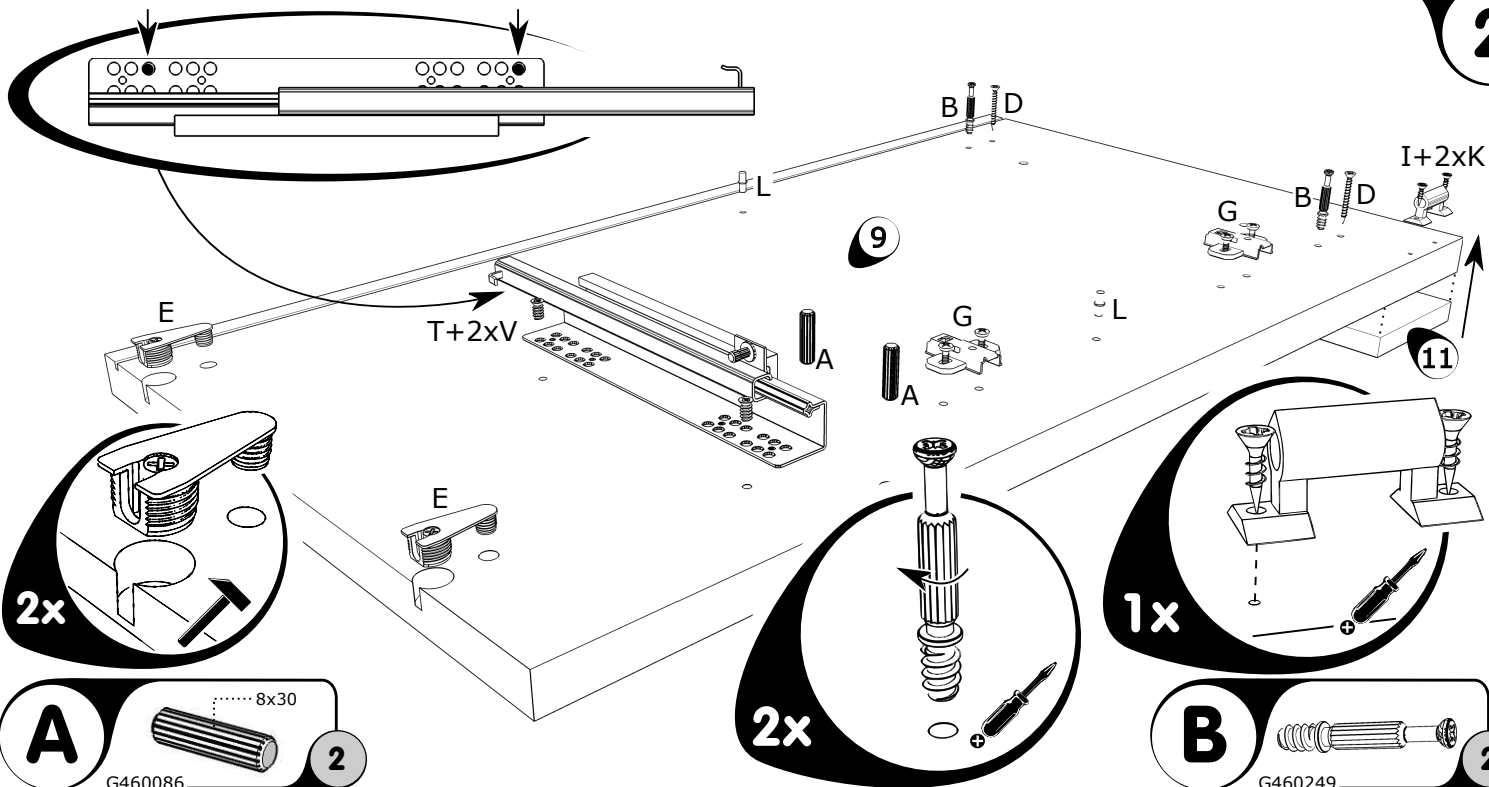

A 8x30
G460086 2

D 4x40
G470007 2

K 3.5x16
G470013 2

E G460265 2

T G460858 1

G G440107 2

V 6.3x10.5
G470077 2

B G460249 2

I G4608831 1

L G460811 2

3

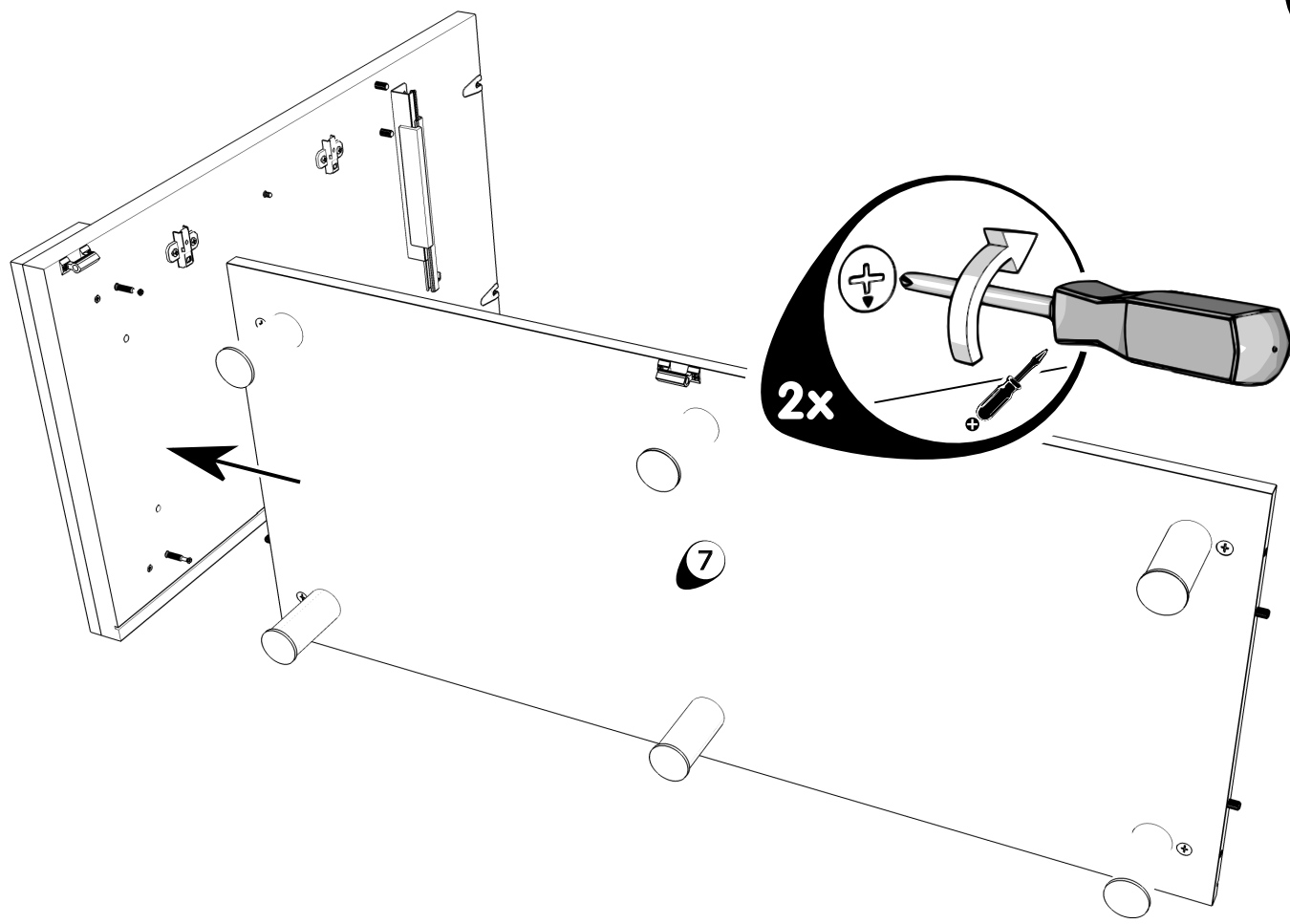

2x

7

4

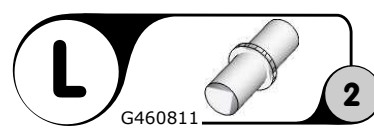
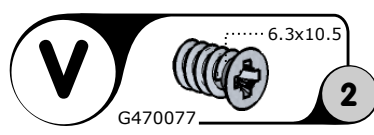
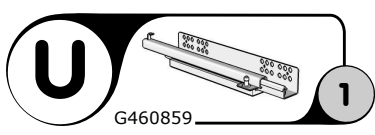
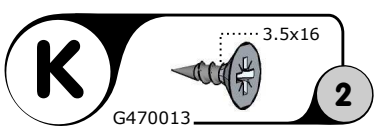
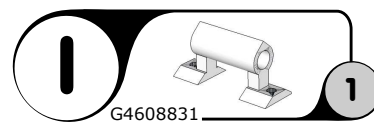
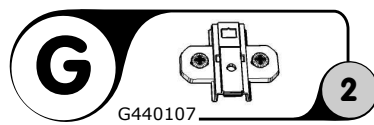
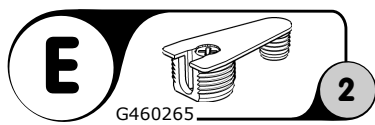
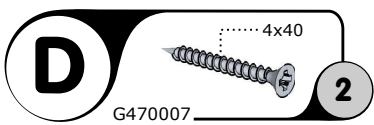
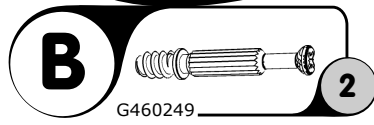
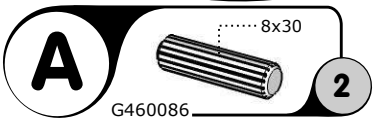
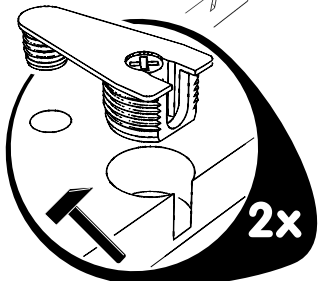
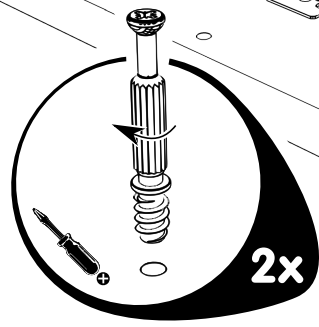
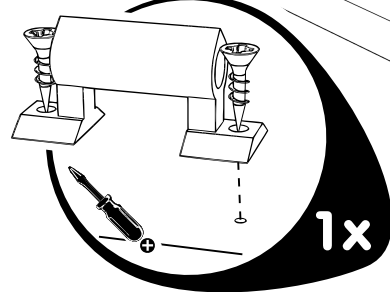
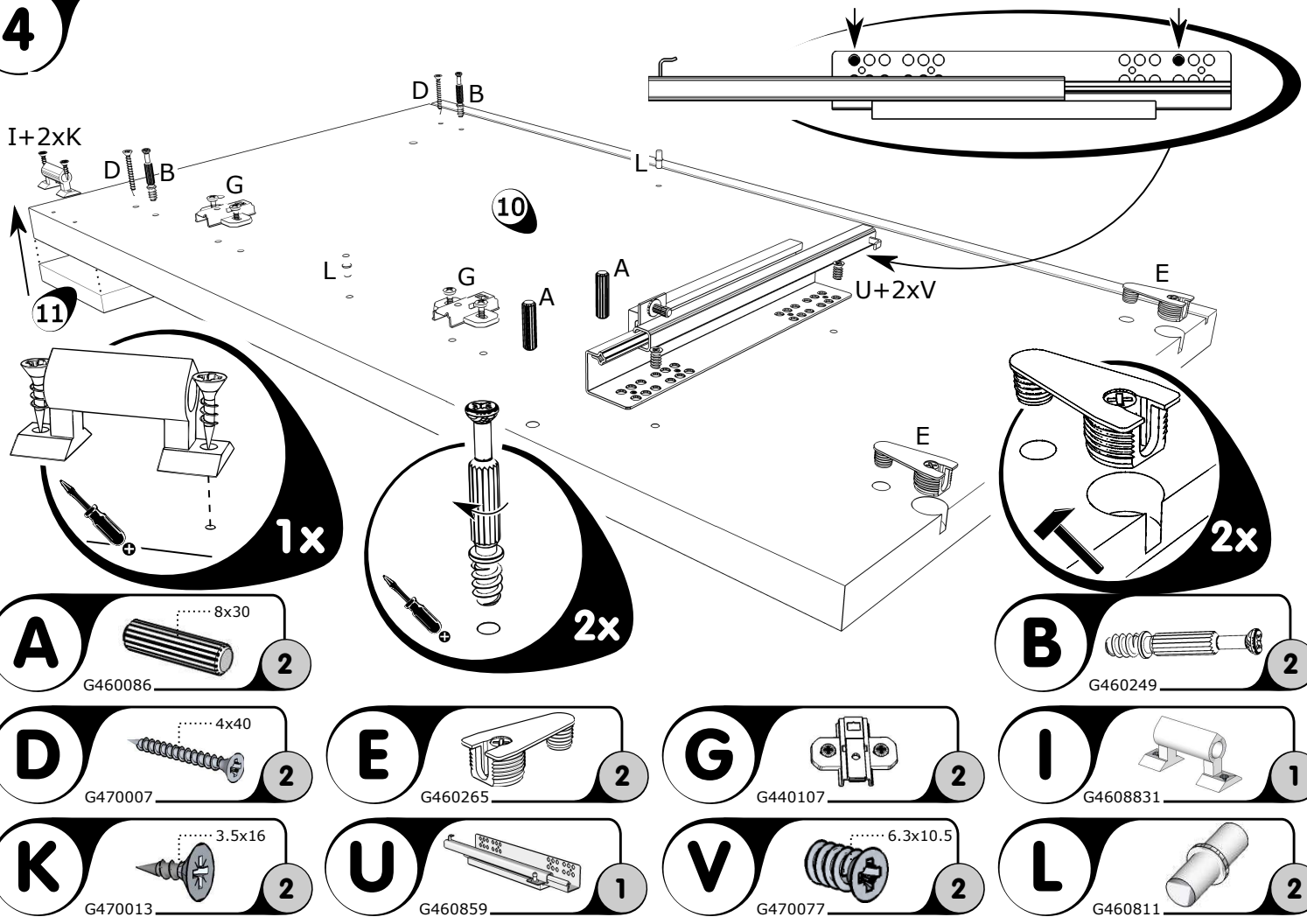

5

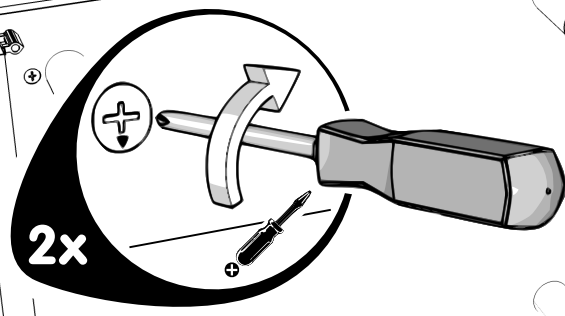
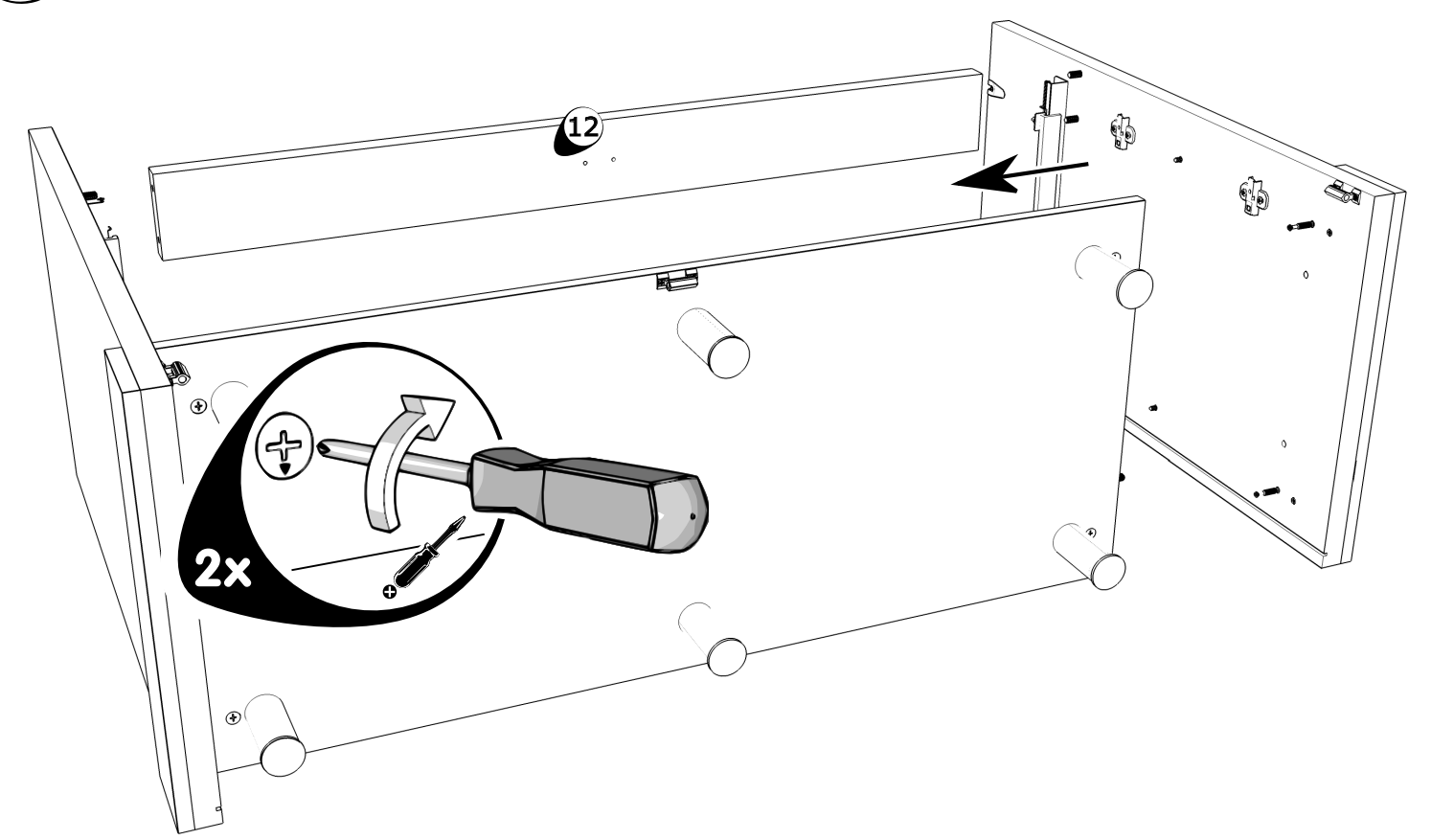

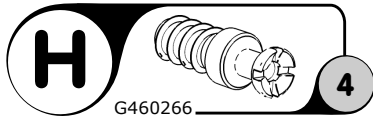
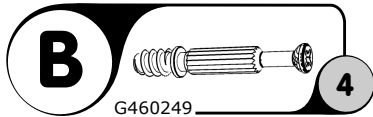
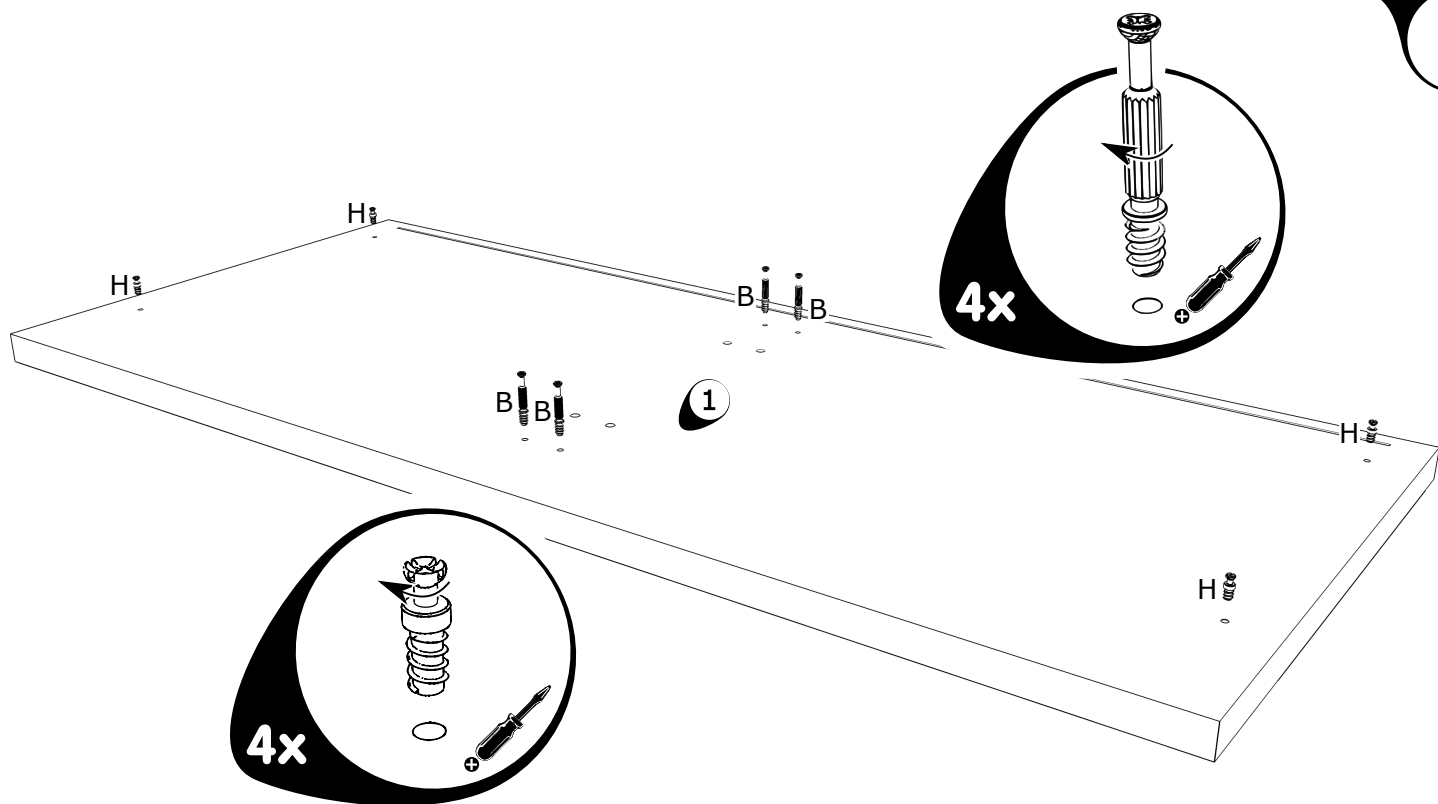
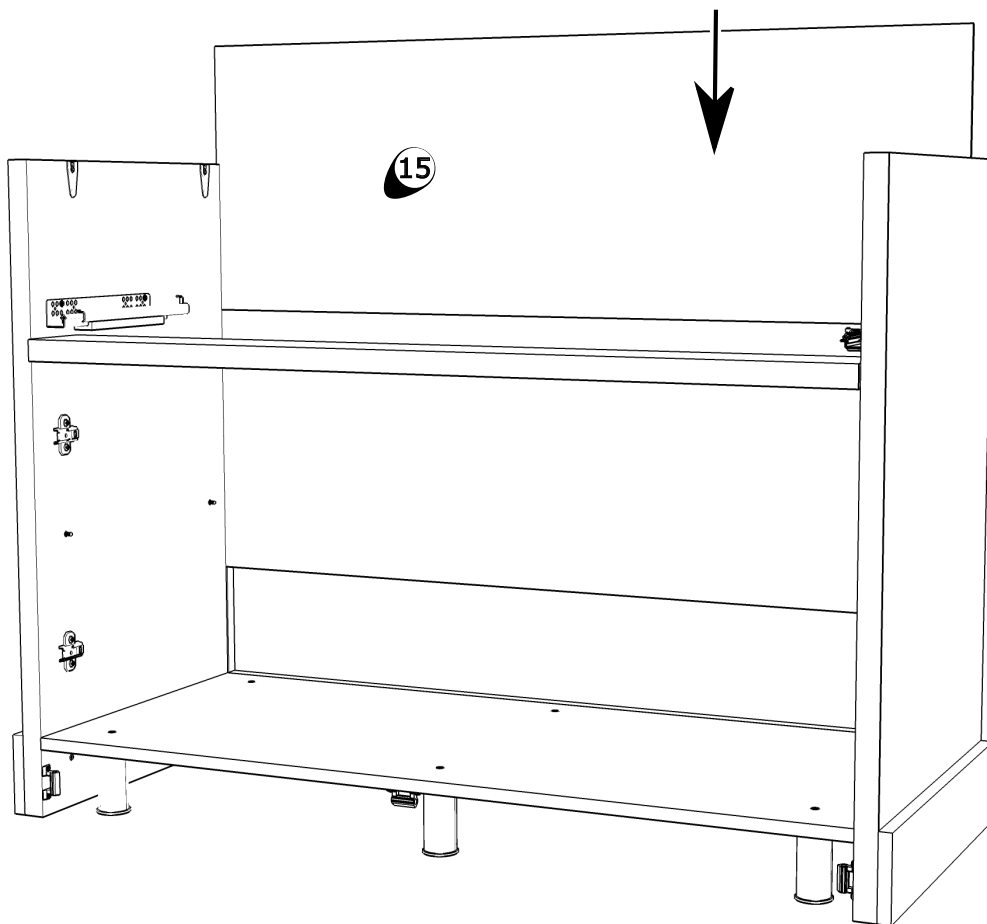

8

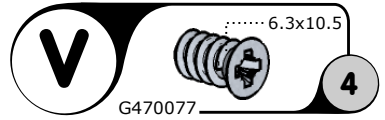
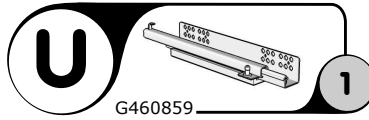
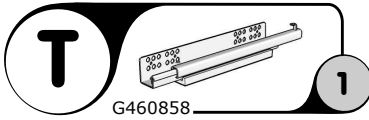
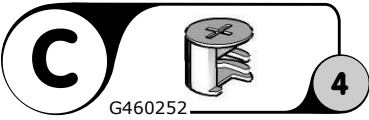
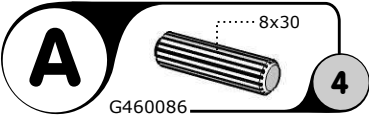
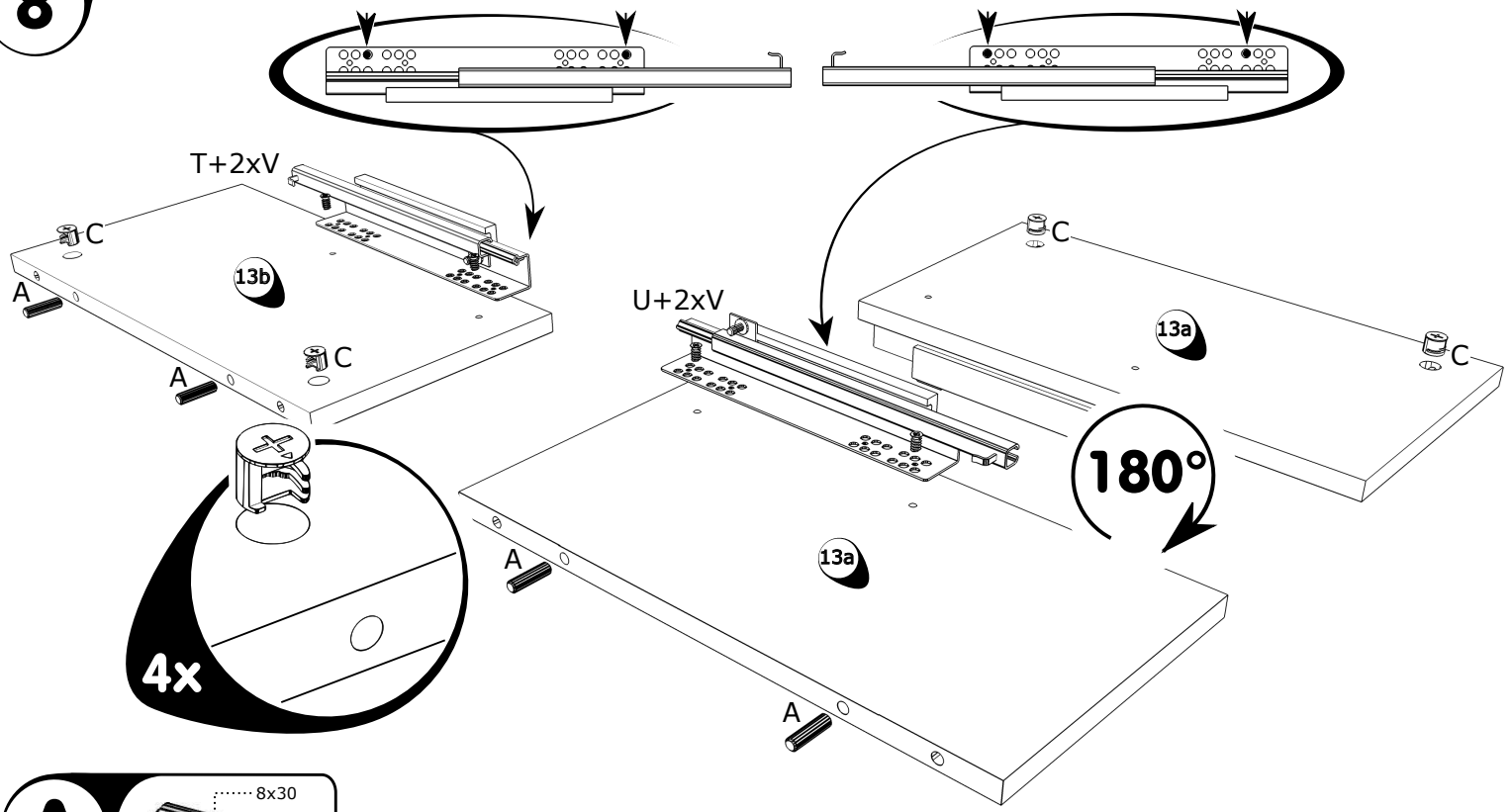

9

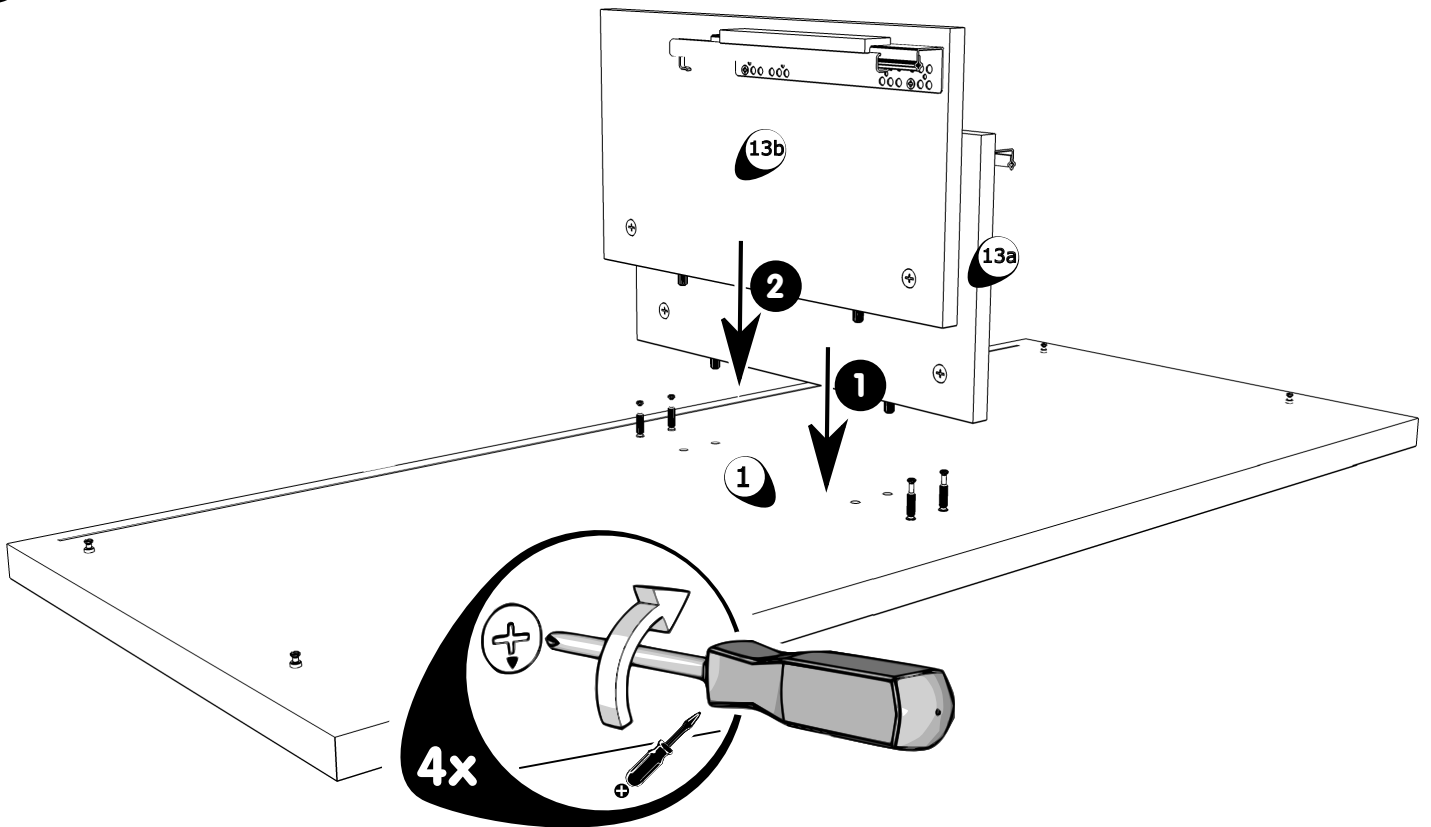

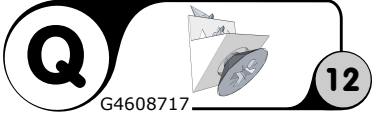
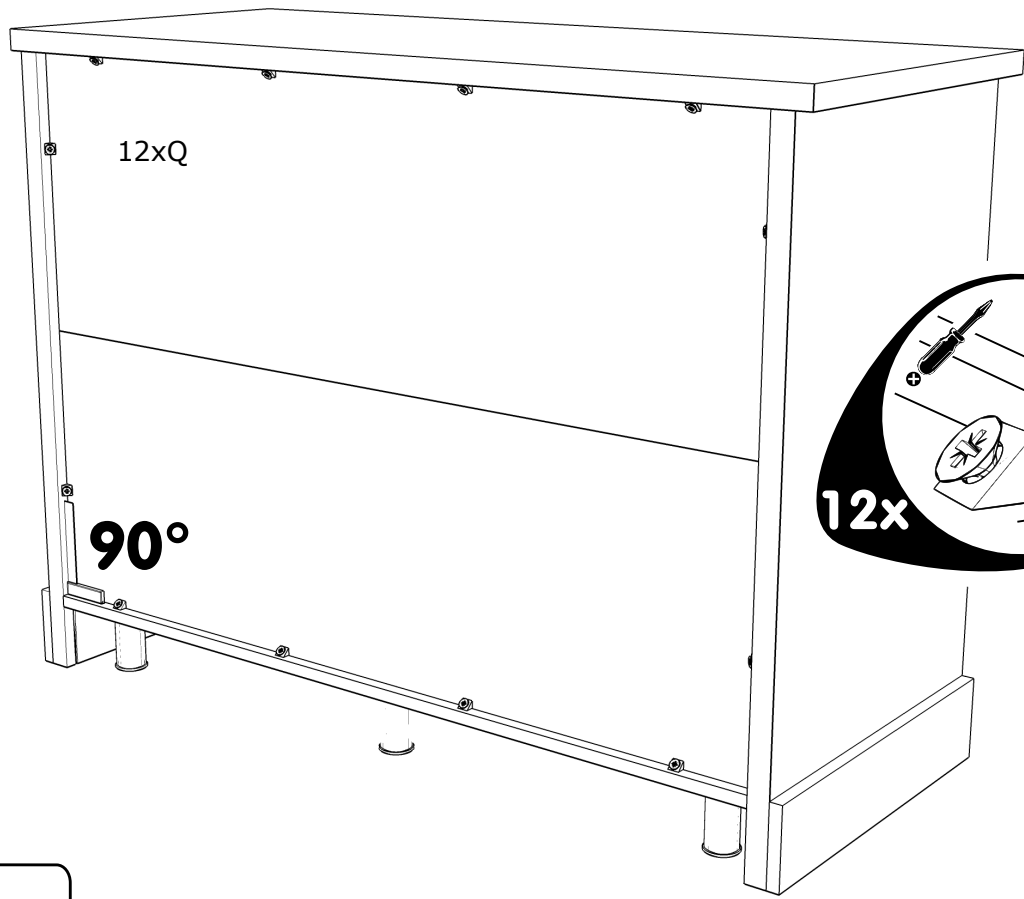
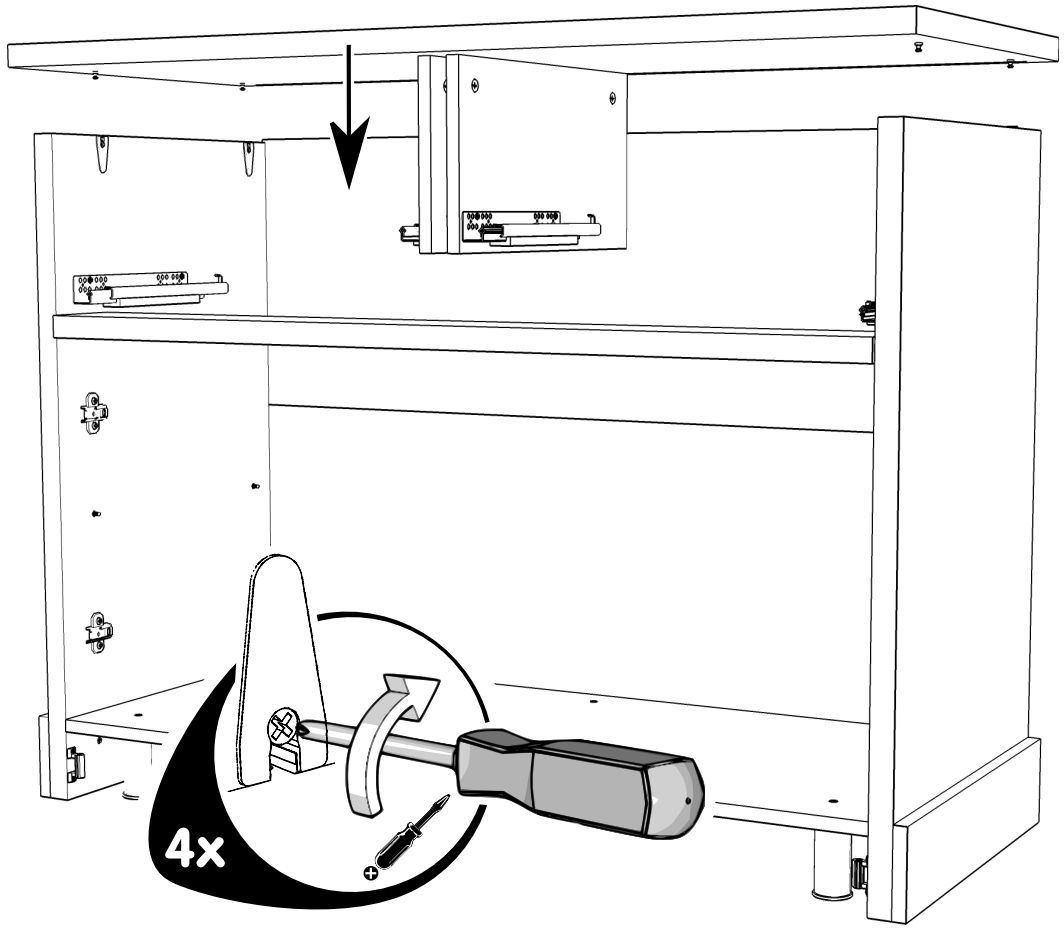

12

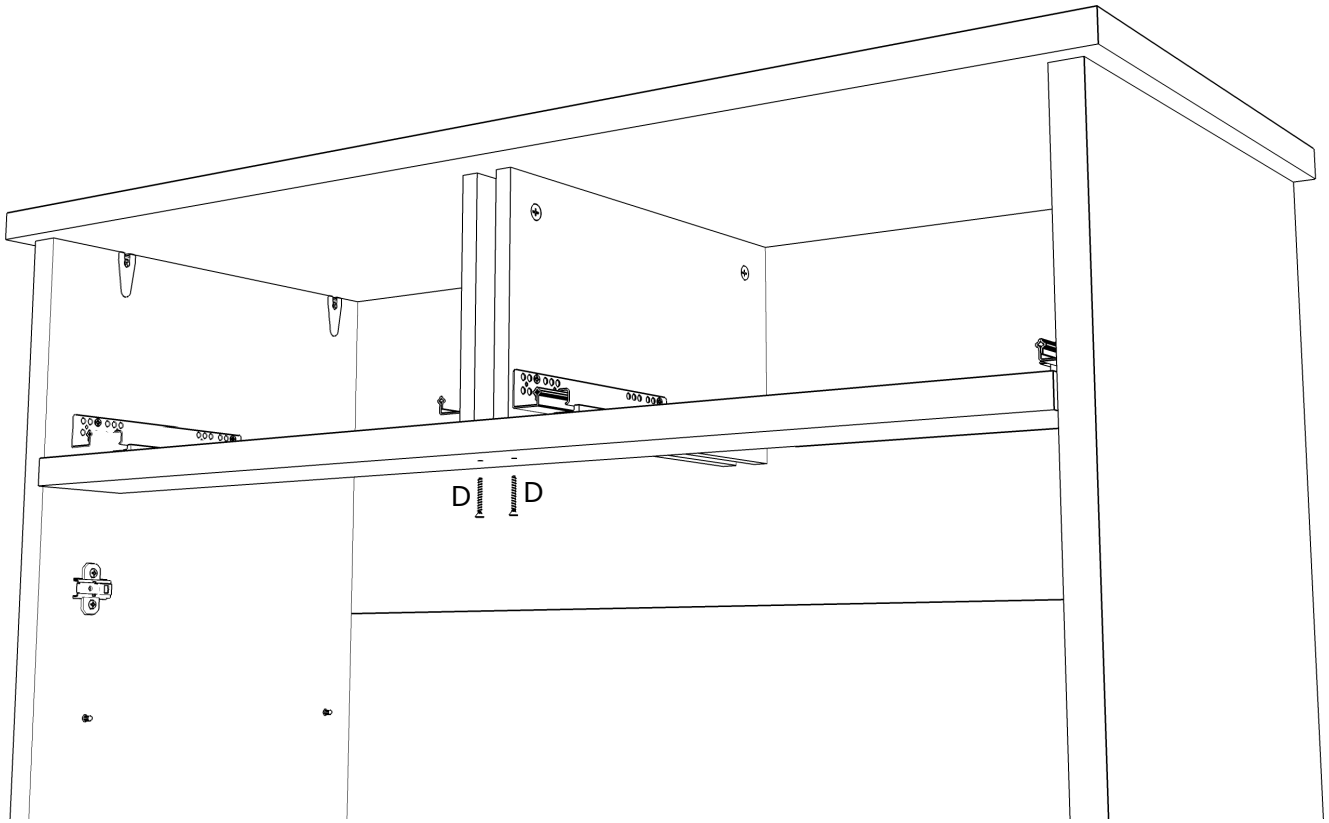

D

4x40

2

G470007

13

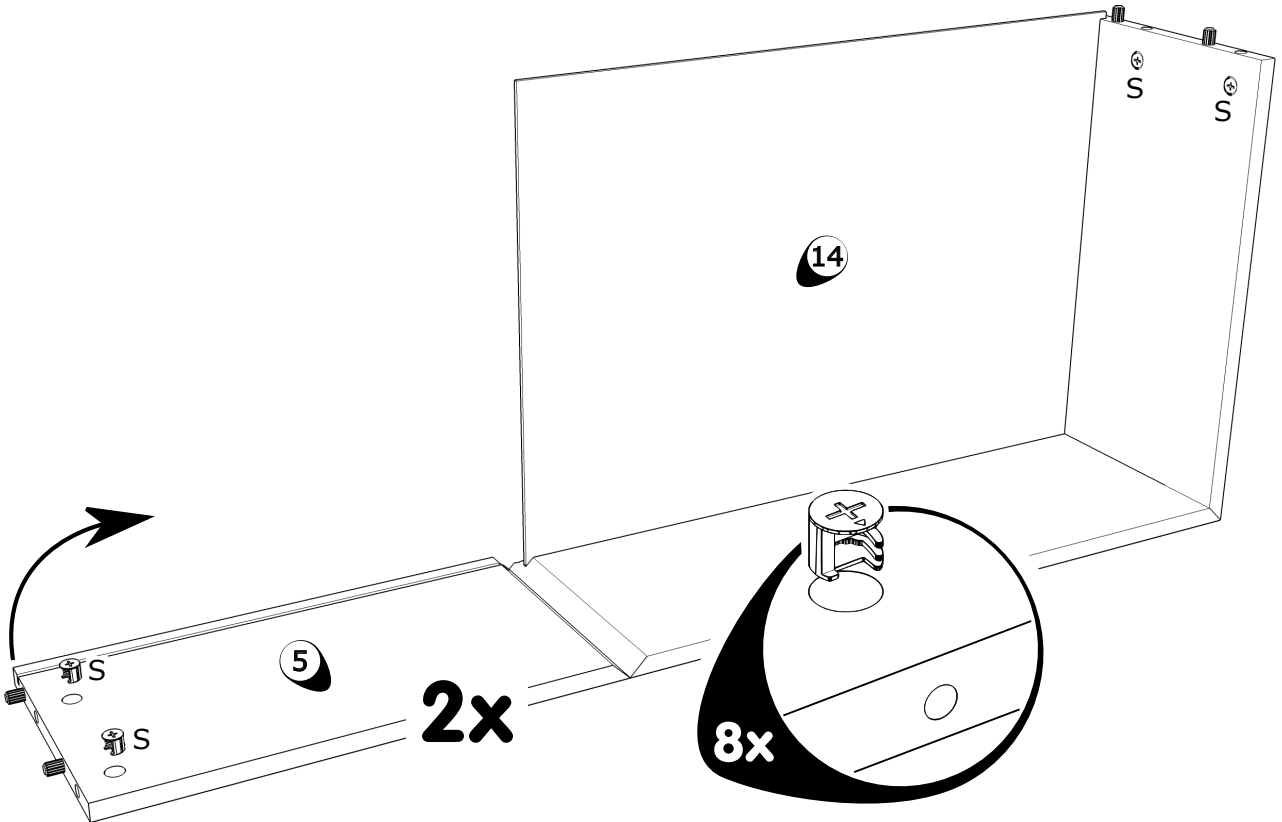

S



8

G430101

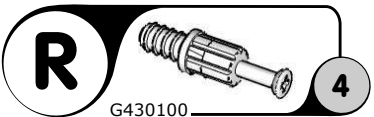
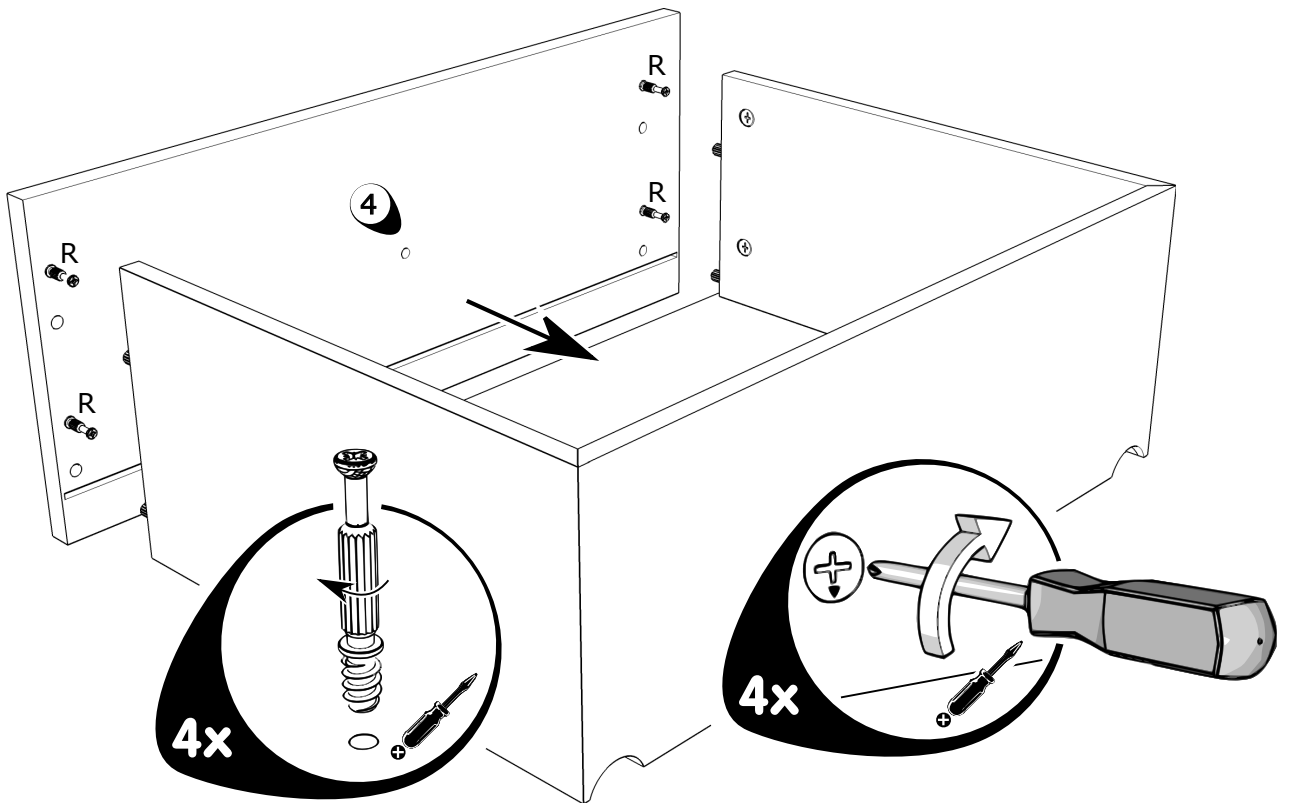
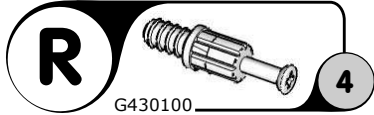
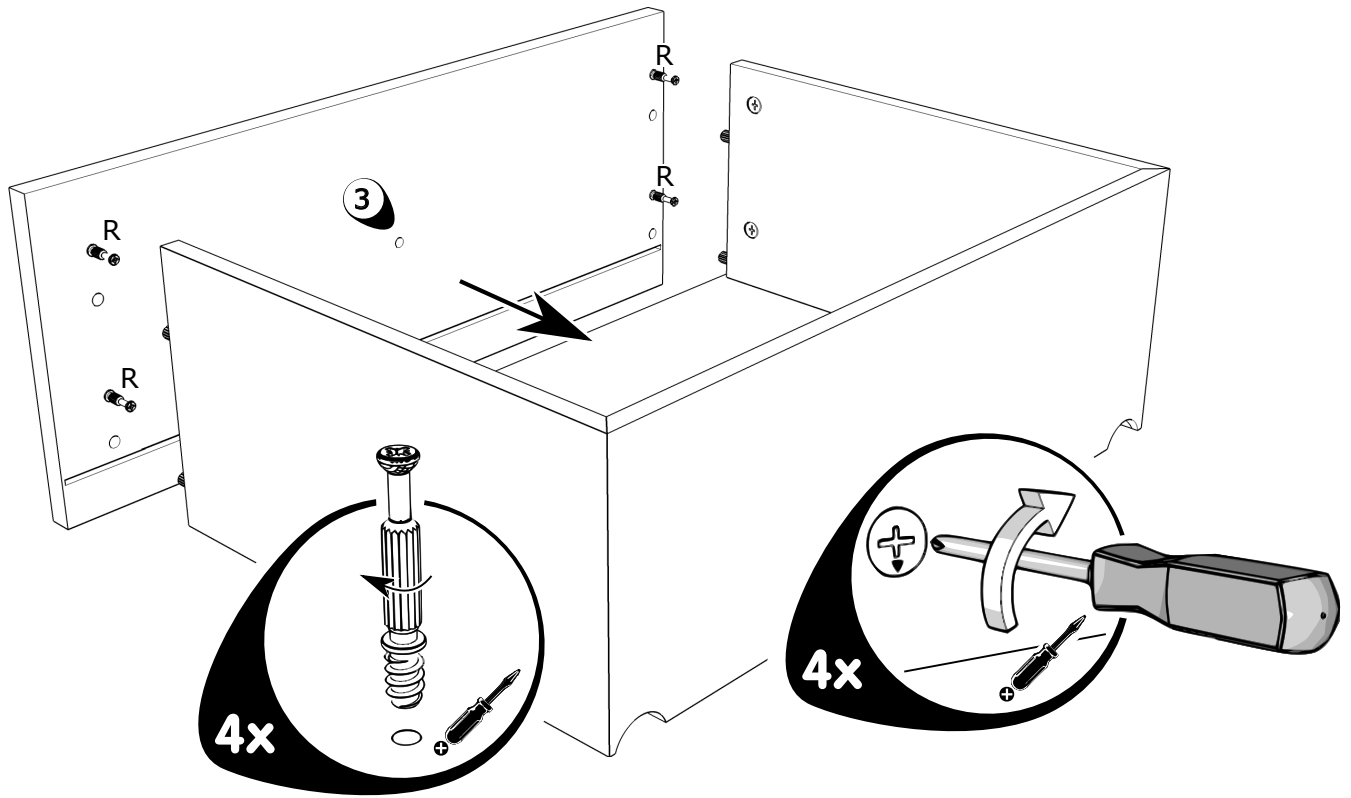

16

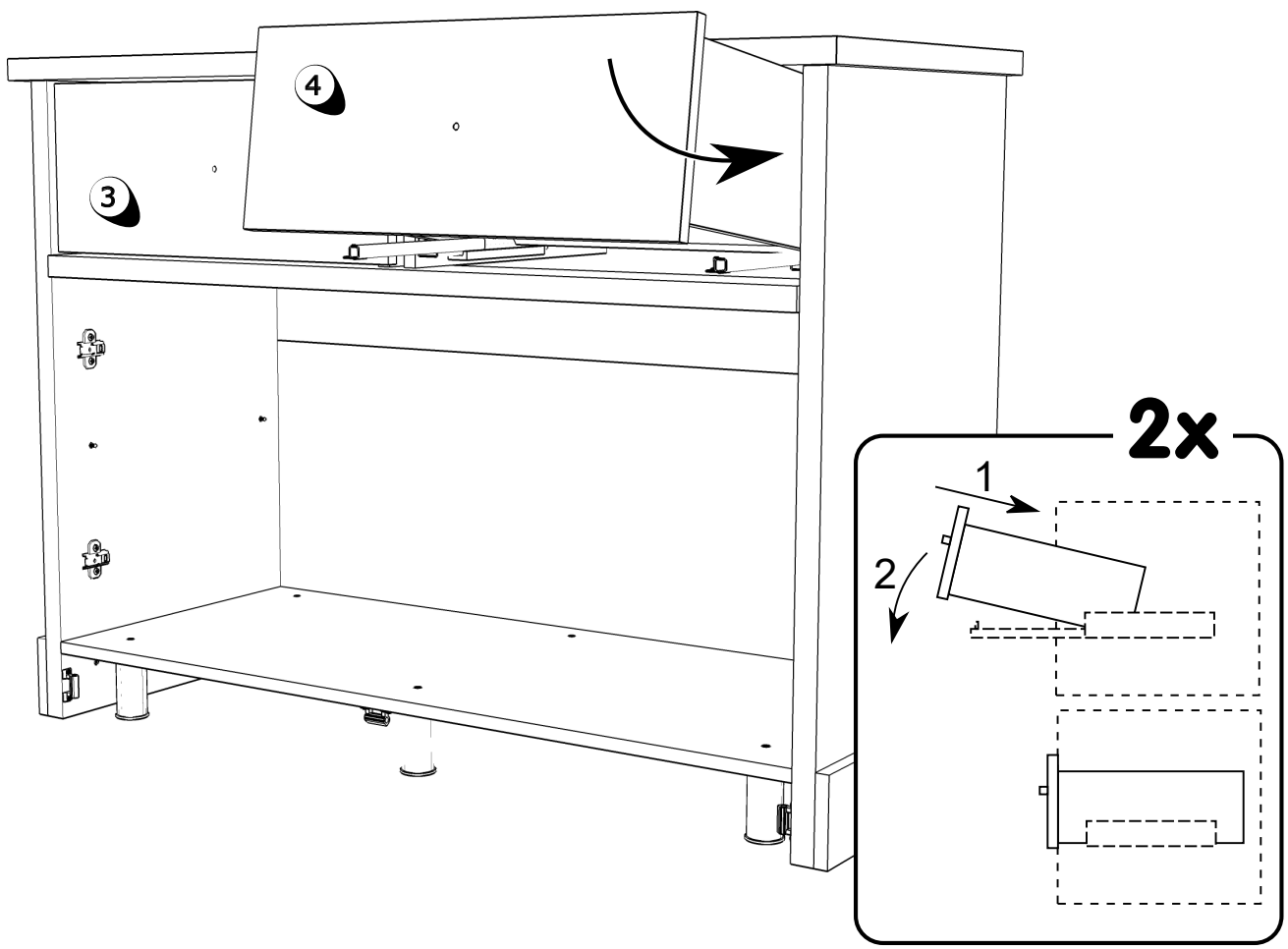

17

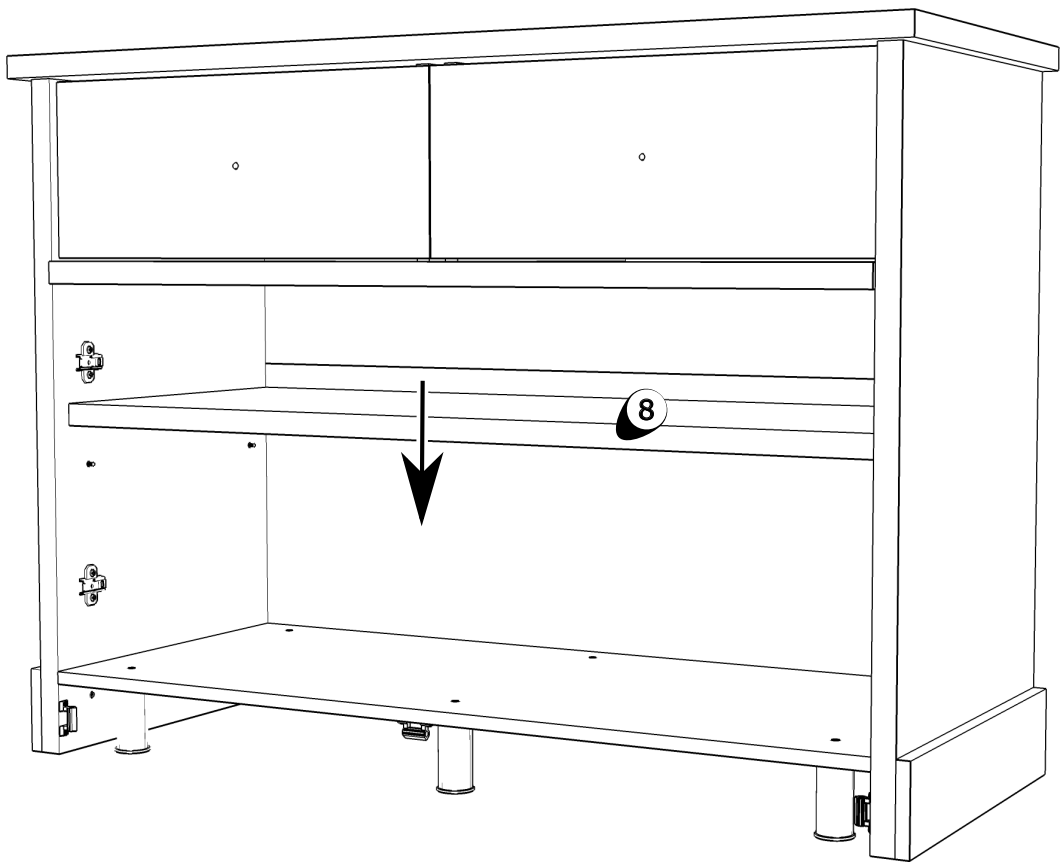

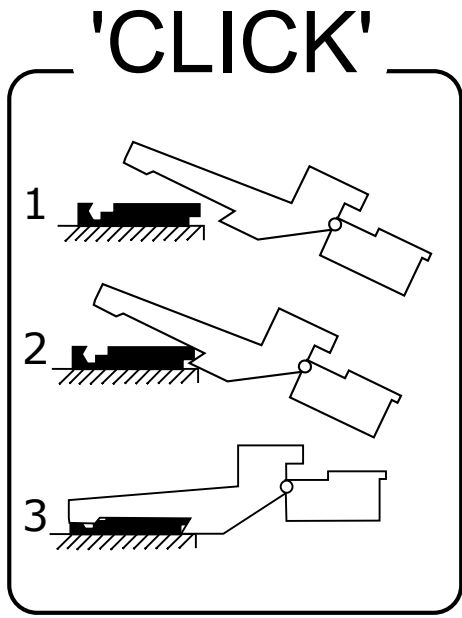
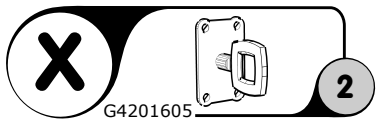
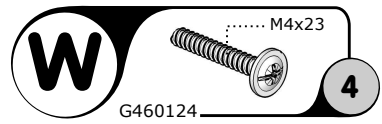
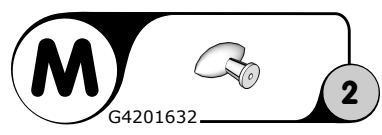
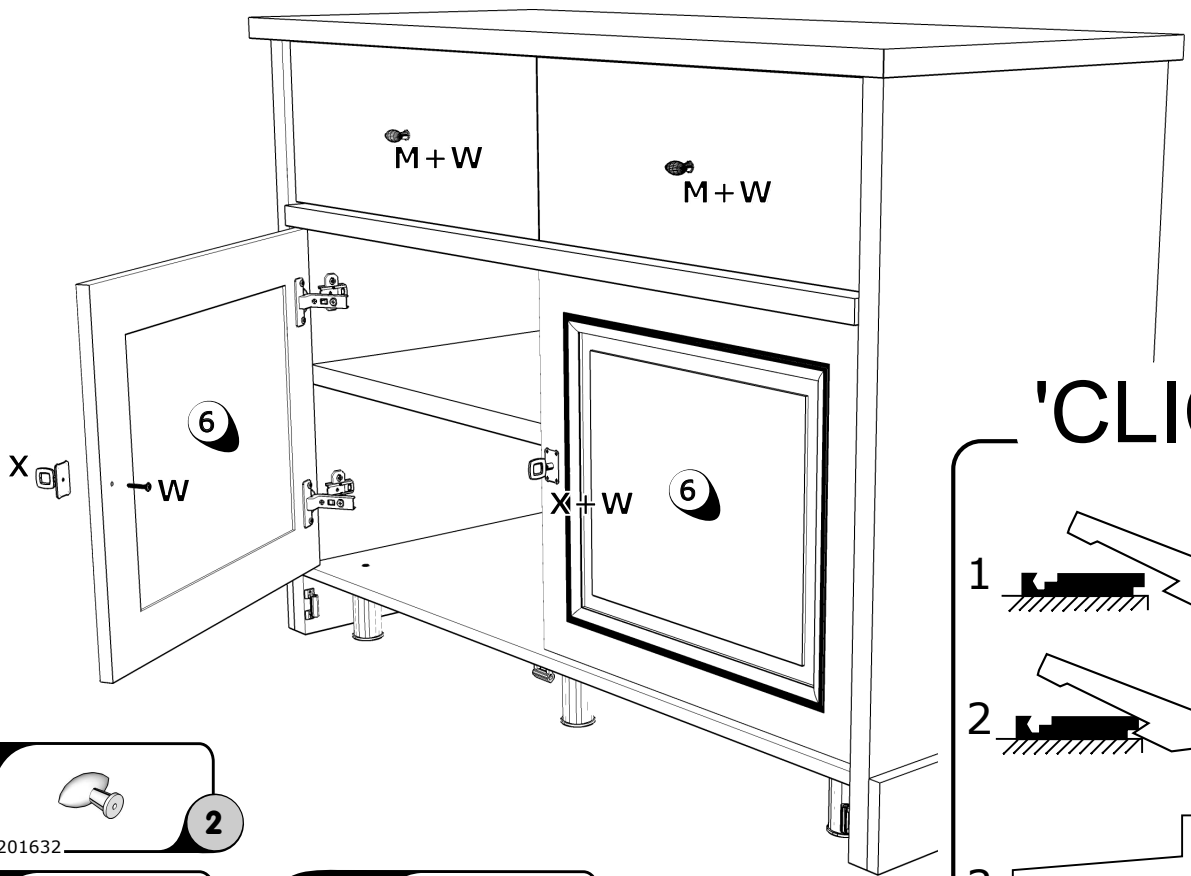
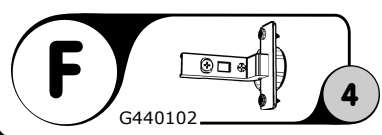
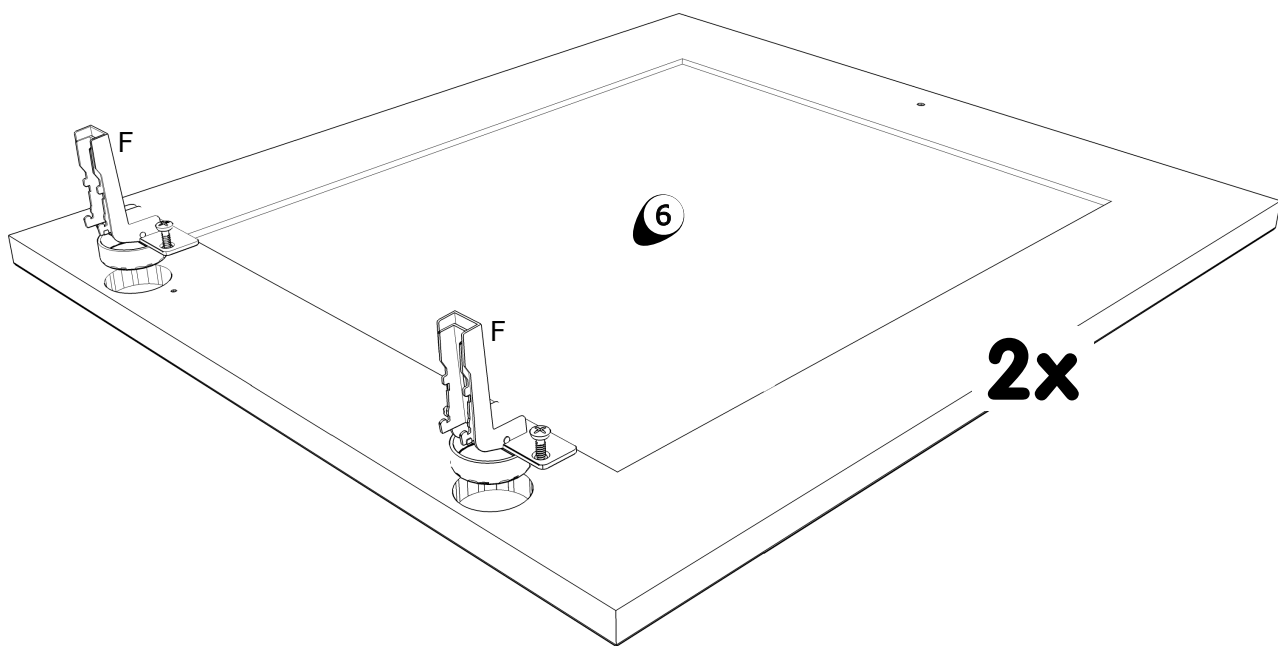

20

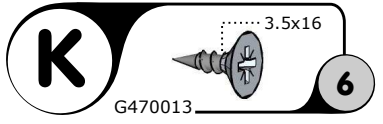
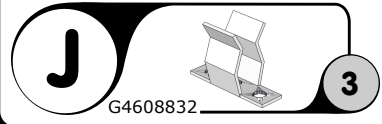
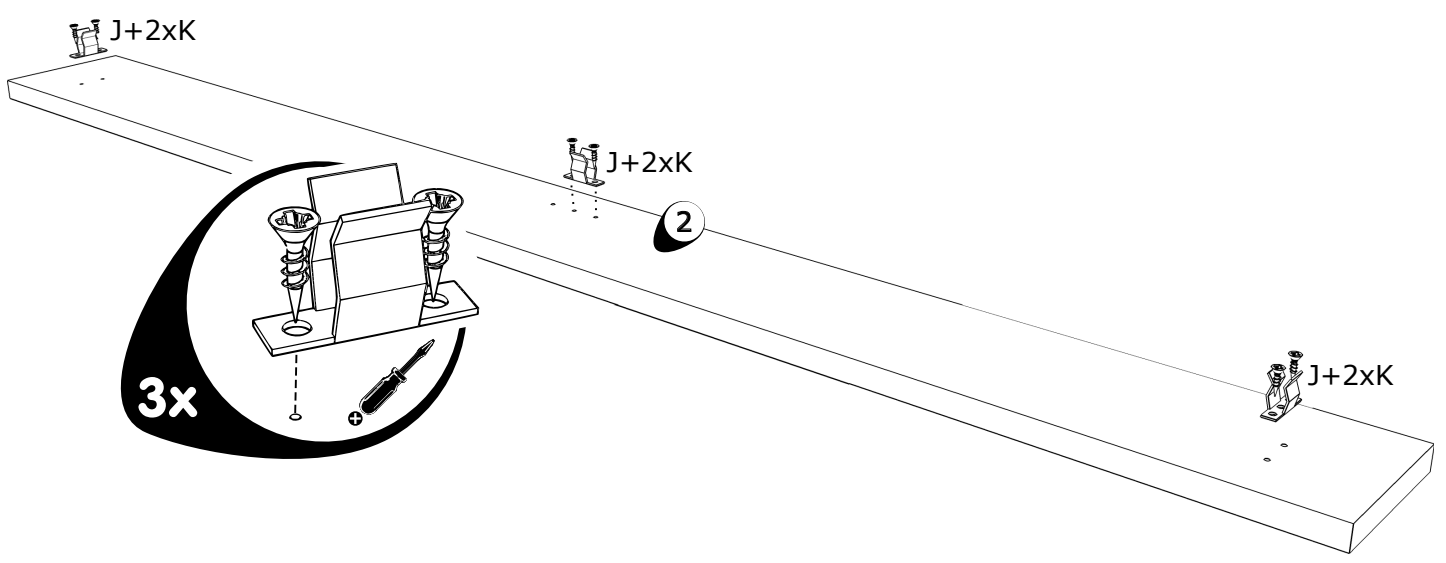

21

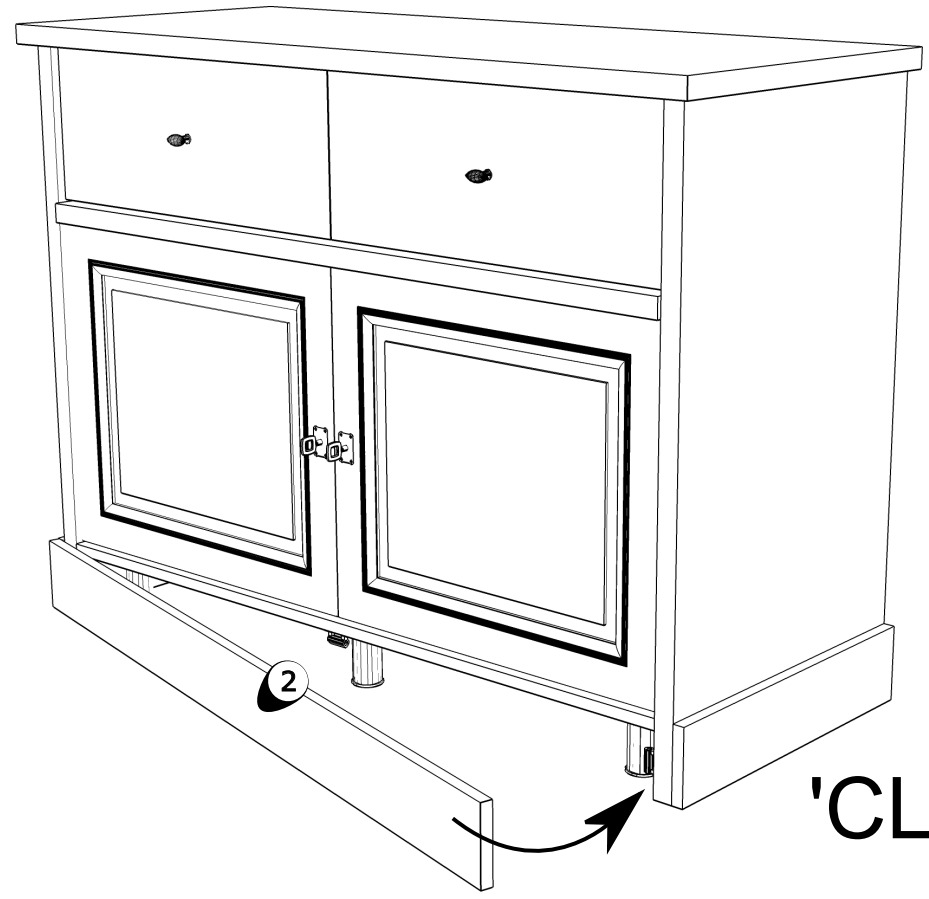

'CLICK'

GEGEVENS AANKOPER

INFORMATIONS ACHETEUR - BUYER INFORMATION - KAUFER INFORMATIONEN

WINKEL

MAGASIN - SHOP - GESCHÄFT

PLAATS

LIEU - TOWN - ORT

AANKOOPDATUM

DATE DE L'ACHAT - DATE OF PURCHASE - KAUFDATUM















REFERENTIE

REFERENCE - REFERENCE - REFERENZ

KLEUR

COULEUR - COLOR - FARBE



-  T5324486
-  T5224503
-  T5324513
-  T5324514
-  G4311262
-  G4807695
-  T5322687
-  T5323014
-  T5322689
-  T5322690
-  T5322500
-  T5324508
-  T5322701
-  G100896 L 493 B348
-  G100974 L 1107 B757

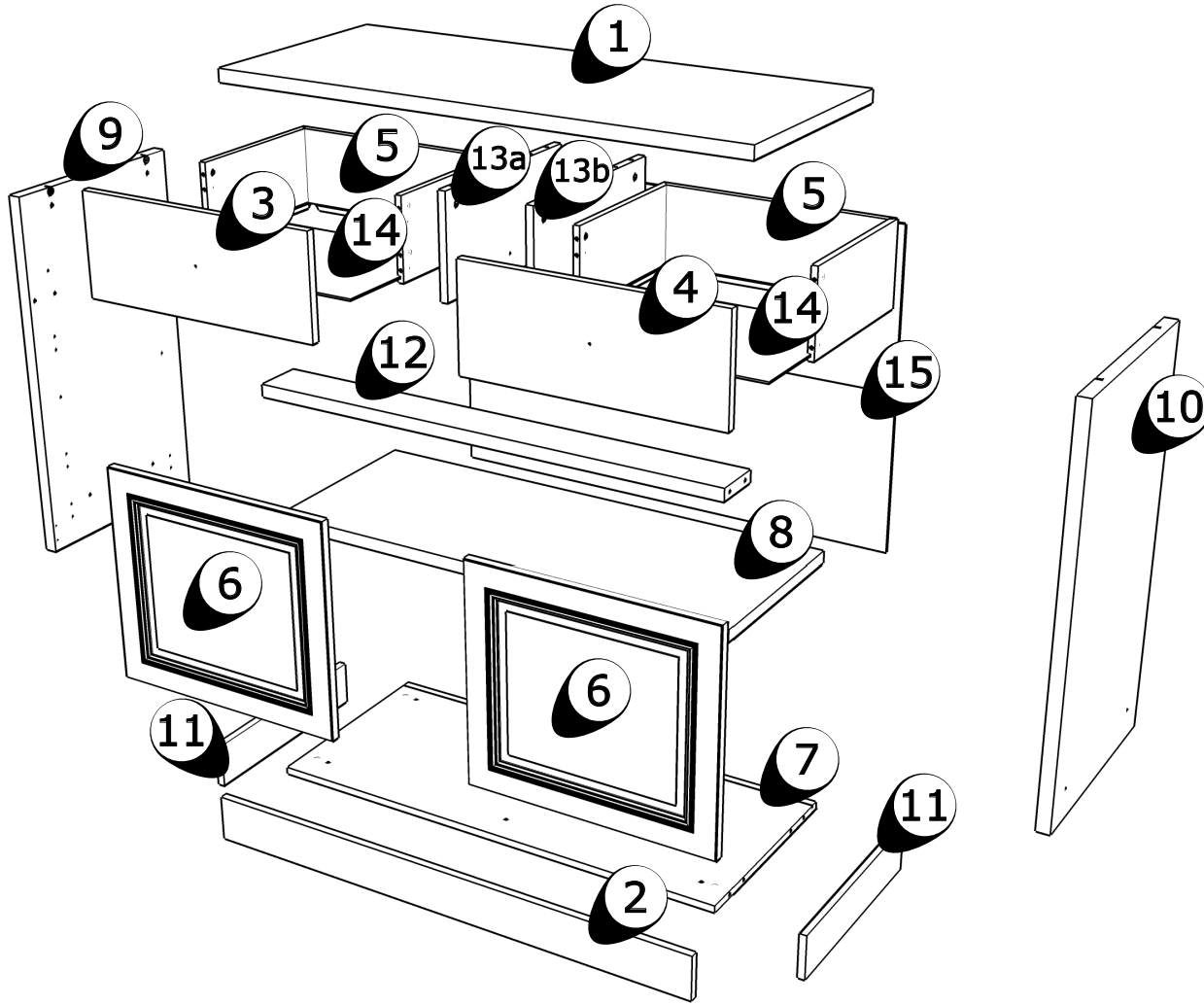

TOELICHTING EXPLICATIONS - EXPLANATION - ERKLÄRUNG

Blank area for technical specifications or notes.

GEGEVENS AANKOPER

INFORMATIONS ACHETEUR - BUYER INFORMATION - KAUFER INFORMATIONEN

WINKEL

MAGASIN - SHOP - GESCHÄFT

PLAATS

LIEU - TOWN - ORT

AANKOOPDATUM

DATE DE L'ACHAT - DATE OF PURCHASE - KAUFDATUM

REFERENTIE

REFERENCE - REFERENCE - REFERENZ

KLEUR

COULEUR - COLOR - FARBE

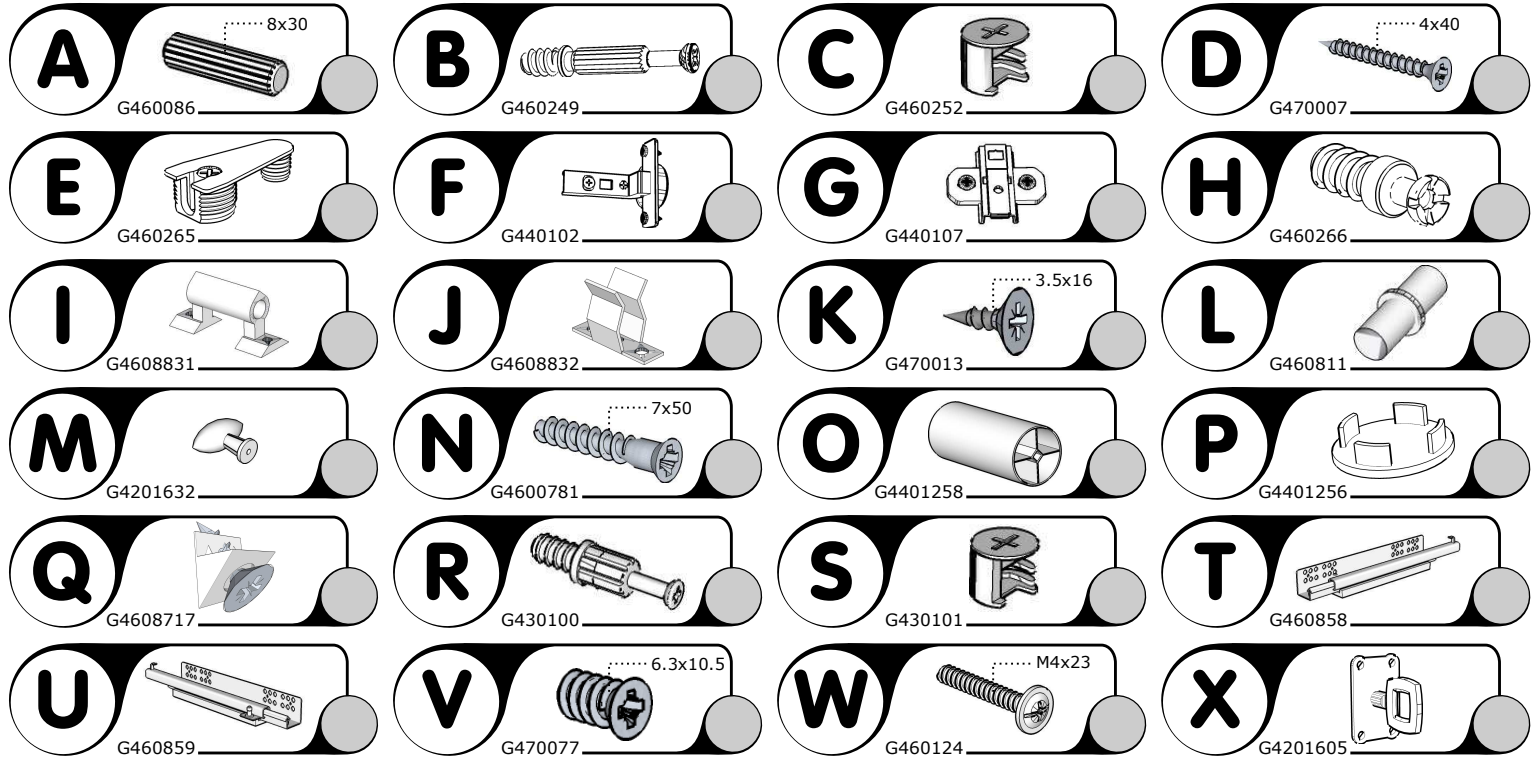
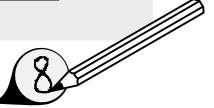

TOELICHTING EXPLICATIONS - EXPLANATION - ERKLÄRUNG

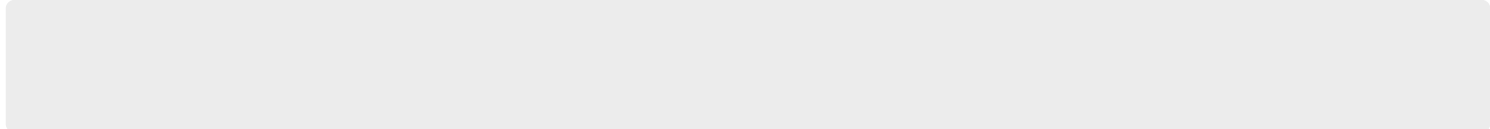

1

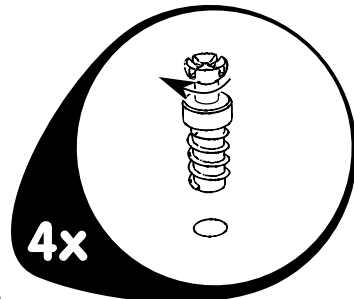
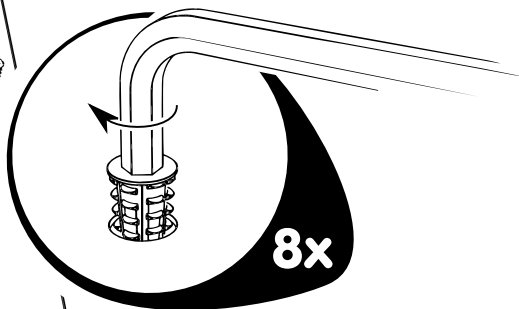
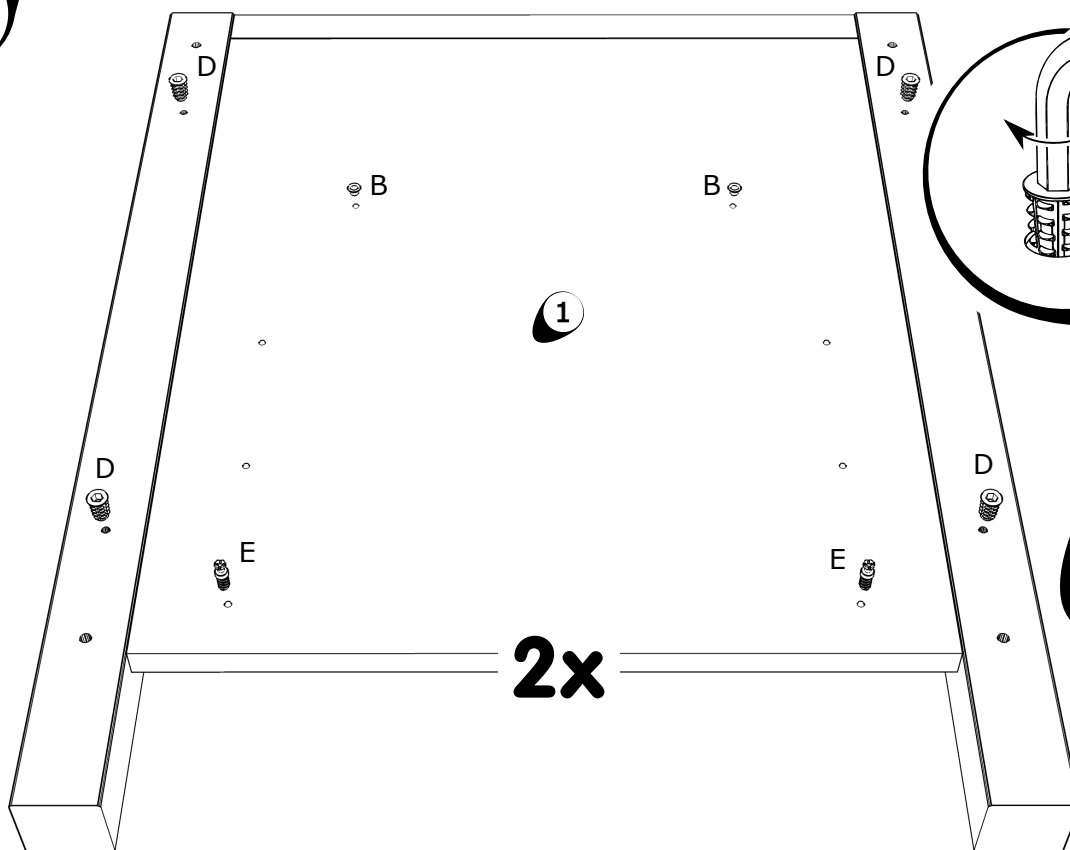

B

K024
G460130



4

D

G4650068

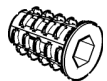

8

E

G460266

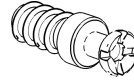

4

2

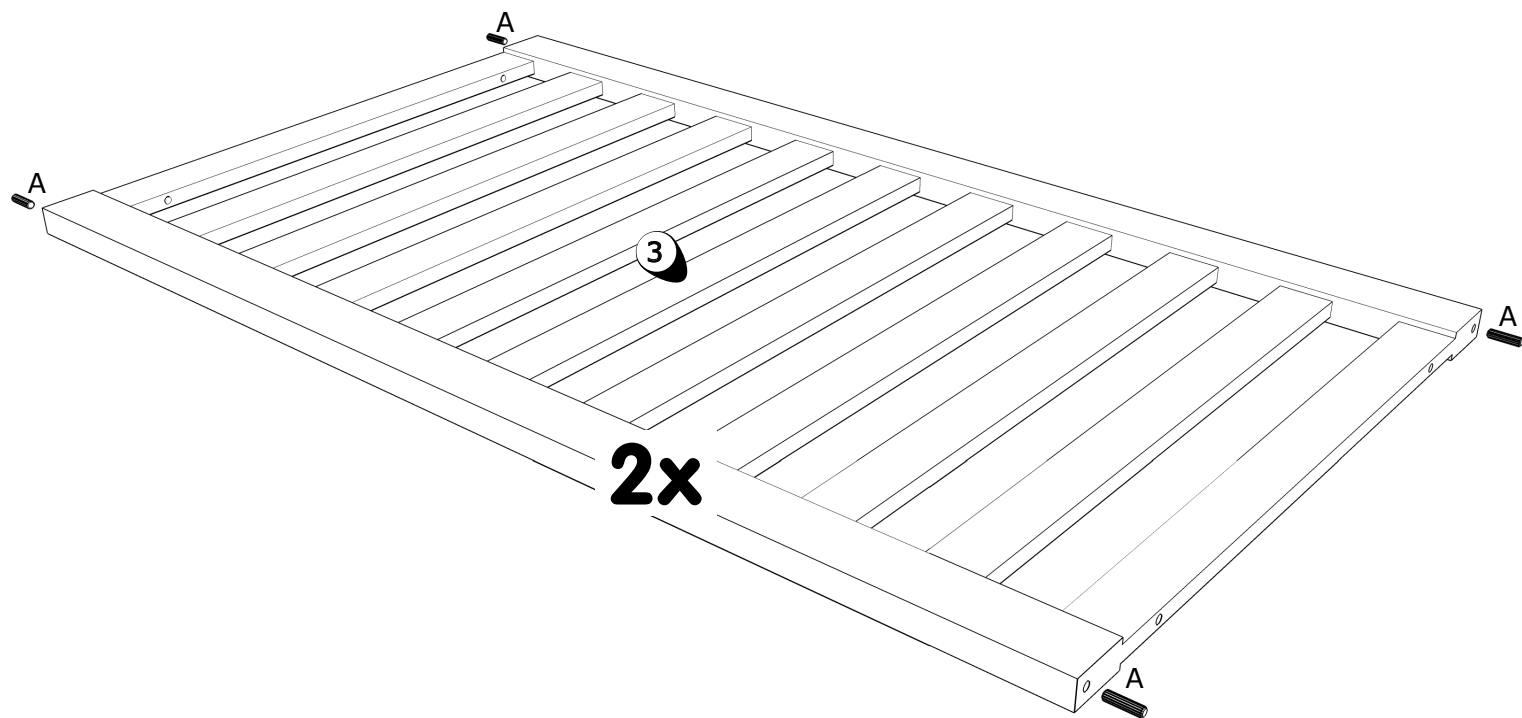

A

G460086

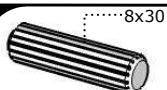

8

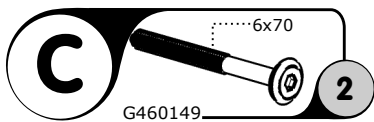
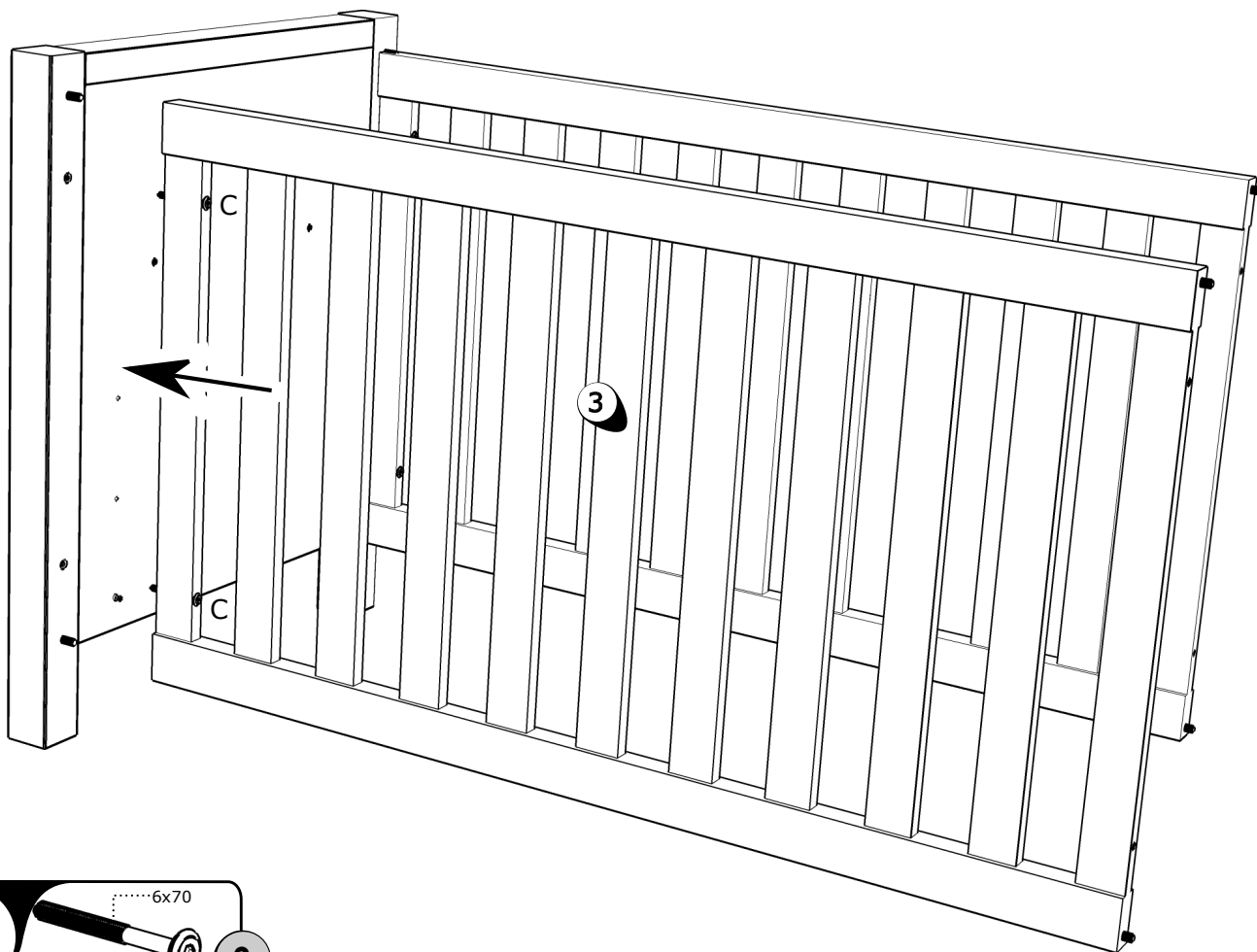
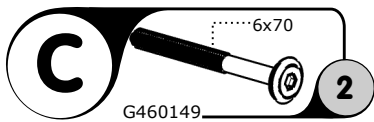
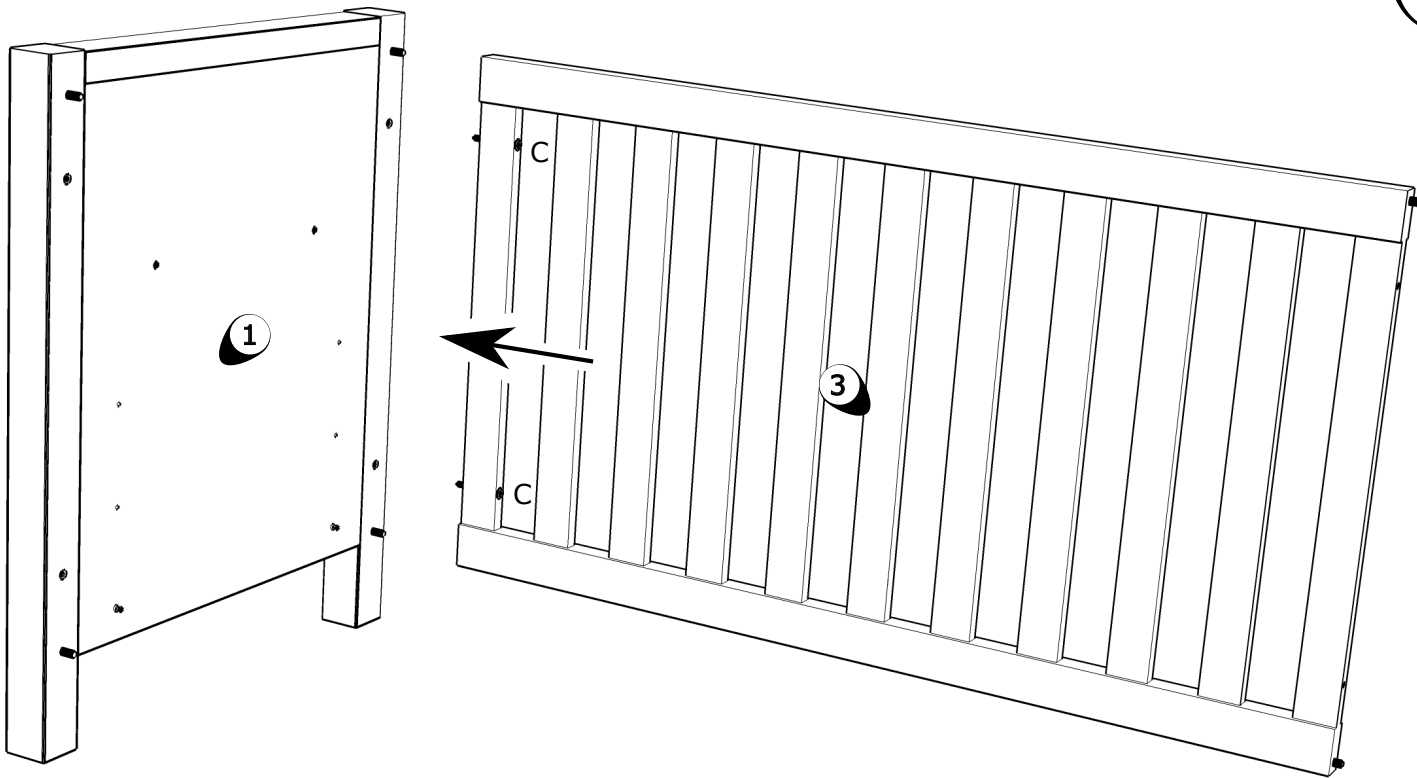

5

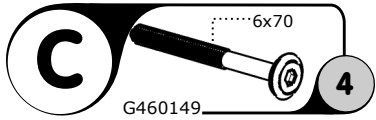
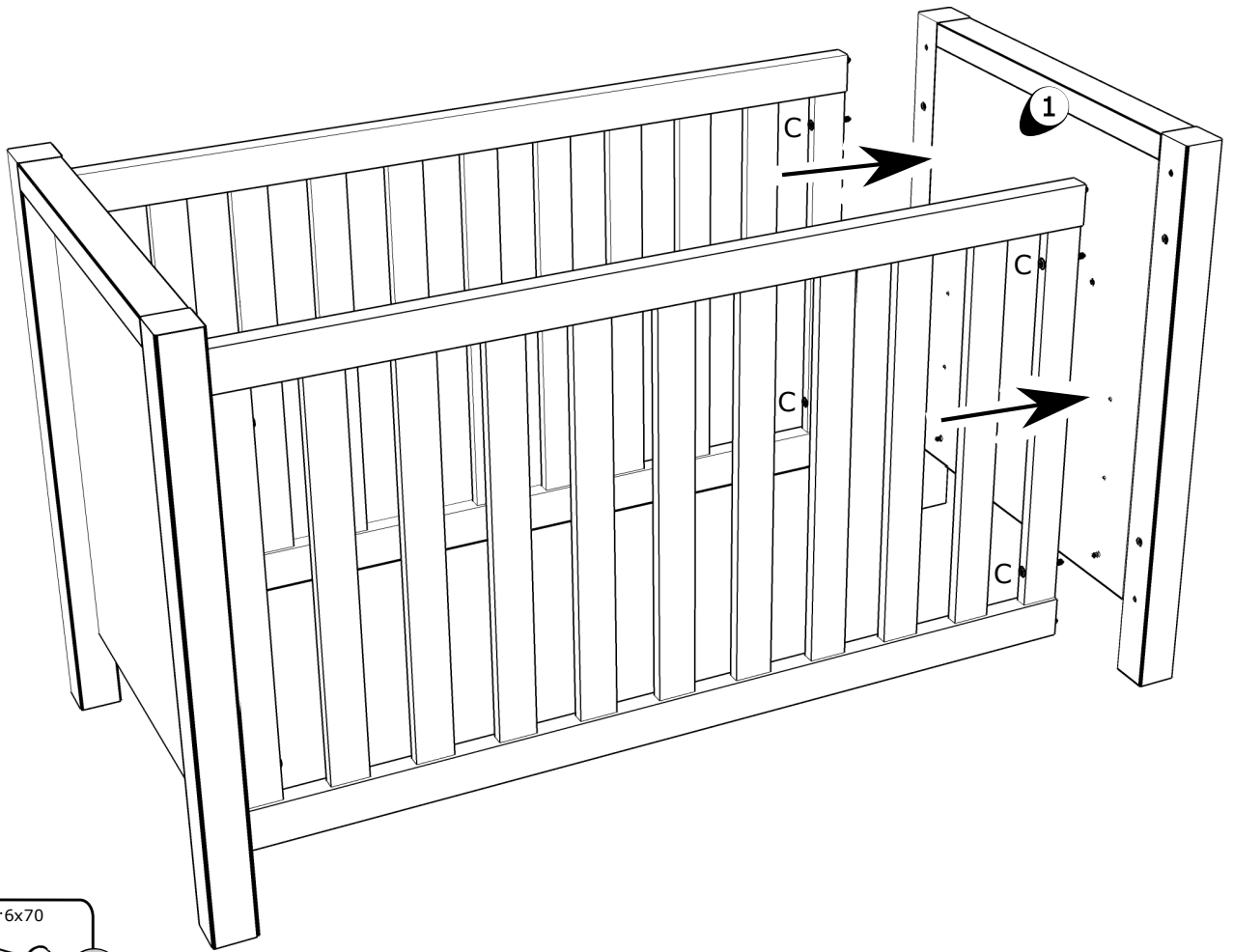

6

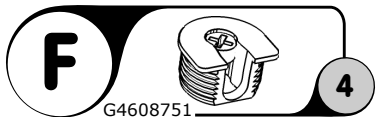
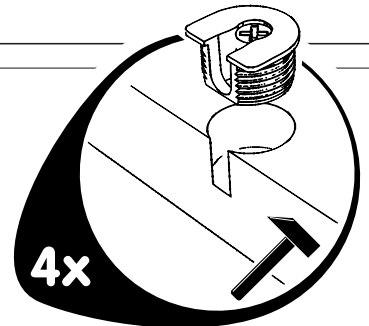
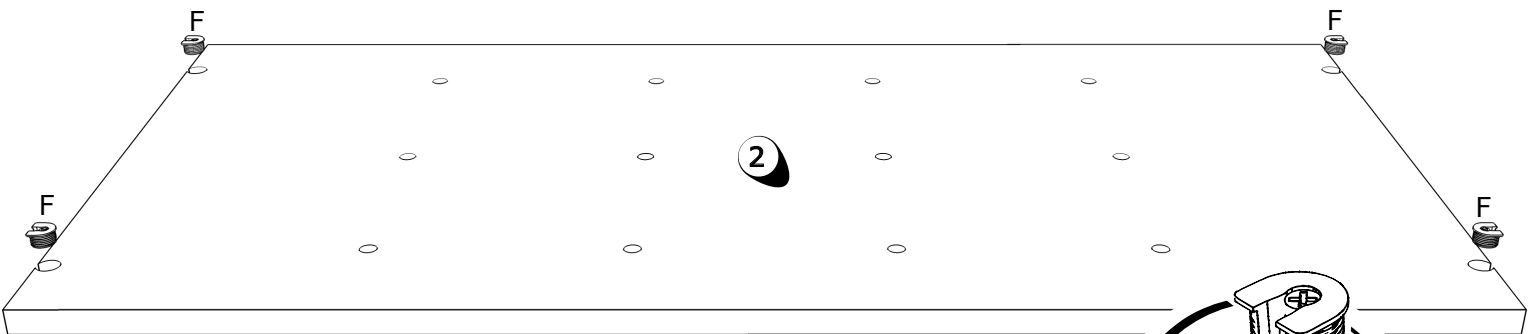

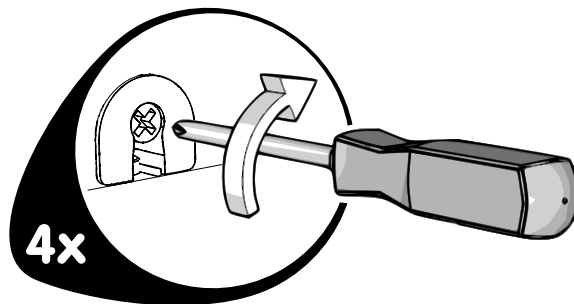
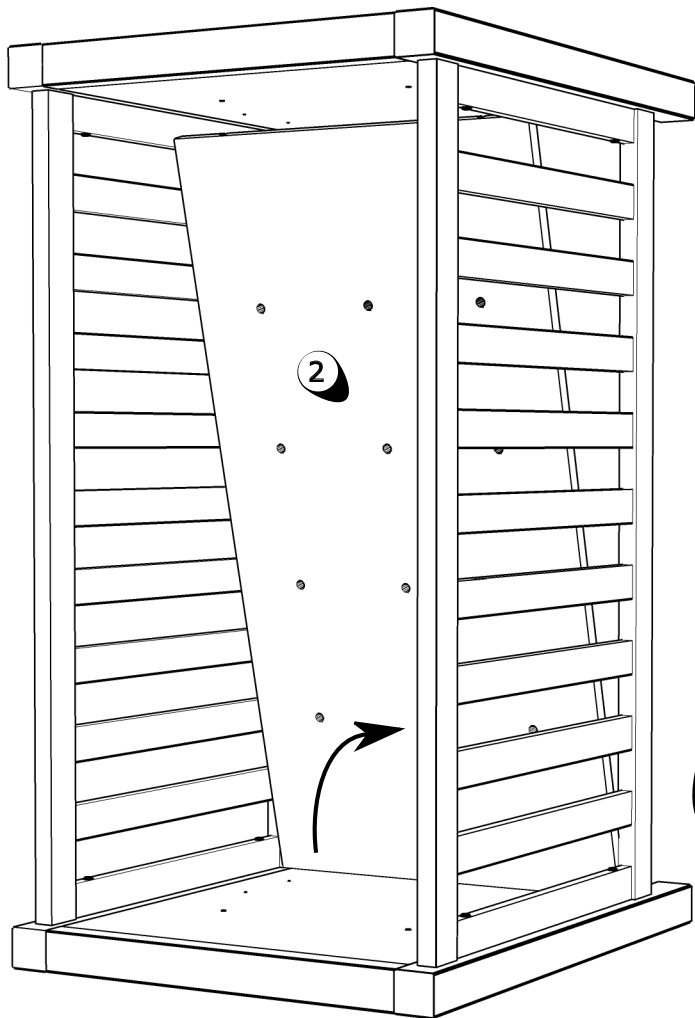

BELANGRIJK – LEES AANDACHTIG EN BEWAAR VOOR HERGEBRUIK.

1. De laagste bodemstand is de veiligste. Zodra het kind aanstalten maakt tot rechtzitten moet de bodem in de laagste stand geplaatst worden.
2. Verstelbare zijkanten moeten steeds in de hoogste stand staan!
3. Laat nooit voorwerpen (bvb. Onverantwoord speelgoed) achter in het bed!
4. Bij de matraskeuze bedraagt de afstand tussen de matras en het laagste punt van de zijkanten minstens 20 cm in hoogste bodemstand. In laagste bodemstand is de afstand minstens 50 cm.
5. Volgende matras wordt aanbevolen: afmetingen lengte 1200mm, breedte 600mm, dikte 100mm.
6. Houd het bed buiten het bereik van warmtebronnen!

IMPORTANT: LIRE ATTENTIVEMENT ET GARDER POUR REUTILISATION.

1. Pour la sécurité de l'enfant, la position la plus basse du fond est préférable. Aussitôt que l'enfant commence à s'asseoir, il est obligatoire d'utiliser que cette position inférieure.
2. Côtés réglables doivent toujours se trouver dans la position la plus haute.
3. Ne laissez jamais des objets dans le lit (ex. jouets etc.).
4. Pour le choix du matelas, faites que la distance entre le matelas et le point le plus bas, des côtés soit au moins 20 cm, dans la position la plus haute du fond. Pour la position la plus basse, la distance minimale doit être 50 cm.
5. Nous conseillons un matelas avec les dimensions suivantes : longueur 1200mm, largeur 600mm et épaisseur 100mm.
6. Gardez le lit à distance de tout source de chaleur.

EN

IMPORTANT: READ CAREFULLY AND RETAIN FOR FUTURE REFERENCE.

1. A statement that a folding cot is ready for use, only when the locking mechanisms of the folding system are engaged.
2. If the height of the bed is adjustable, a statement that the lowest position is the safest and that the base should always be used in that position as soon as the baby is old enough to sit up. When adjustable sides are provided, the additional statement: "If you leave the child unattended in the cot, always make sure that the dropside is in the highest position".
3. Where detachable support rails are provided to support the bed base above its lowest position, a statement that it is essential to remove these rails before the cot is used in its lowest position.
4. An assembly drawing, a list and description of all parts and tools required for assembly and a diagram of the bolts and other fastenings required.
5. A statement drawing the attention of the user to the risk of leaving anything in the cot which could provide a foothold or present a danger of suffocation or strangulation.
6. A statement that the thickness of the mattress chosen shall be such that the internal height (surface of the mattress to the upper edge of the bed frame) is at least 500mm in the lowest position of the bed base and at least 200mm in the highest position of the bed base.
7. A statement that all assembly fittings should always be tightened properly and that care should be taken that no screws are loose, because a child could trap parts of the body, or clothing (e.g. strings, necklaces, ribbons for babies' dummies), which would pose a risk of strangulation.
8. Recommendation concerning the mattress: length 1200mm, width 600mm, thickness 100mm.
9. A warning to be aware of the risk of open fire and other sources of strong heat, such as electric bar fires, gas fires, etc... in the near vicinity of the cot.

DE

ACHTUNG: SORGFALTIG LESEN UND FÜR SPÄTERES NACHSCHLAGEN AUFBEWAHREN.

1. Das Babybett ist für Gebrauch fertig, wenn alle Schließmechanismus richtig befestigt sind.
2. Indem das Bett höhenverstellbar ist: "die niedrigste Position ist am sichersten und muss so sein sofort als das Kind aufrecht sitzen kann. "
3. Indem die Seiten höhenverstellbar sind müssen diese in der höchsten Position stehen als man das Kind alleine im Bett hinterläßt.
4. Nichts im Bett liegen daß für das Kind als Treppe benutzt werden kann oder zu Verstickung oder Aufhängung führen kann.
5. Die Diche der Matratze so wählen daß die interne Höhe (Oberseite Matratze-oberseite Bett) in der niedrigsten Position 500 mm beträgt und bei der höchsten Position 200 mm.
6. Sorgen Sie dafür daß alle Befestigungen sicher befestigt werden und daß keine lose Schrauben für Aufhängung sorgen können als das Kind hängen bleibt mit seinen Kleidung oder Körperteile.
7. Empholenes Maß der Matratze ist 1200 x 600 x 100 mm.
8. Aufpassen daß das Bett nicht zu nahe bei Ofenfeuer oder anderen (z.B. elektrische Heizgeräte) Wärmequellen steht.

GEGEVENS AANKOPER

INFORMATIONS ACHETEUR - BUYER INFORMATION - KAUFER INFORMATIONEN

WINKEL

MAGASIN - SHOP - GESCHÄFT

PLAATS

LIEU - TOWN - ORT

AANKOOPDATUM

DATE DE L'ACHAT - DATE OF PURCHASE - KAUFDATUM

REFERENTIE

REFERENCE - REFERENCE - REFERENZ

KLEUR

COULEUR - COLOR - FARBE

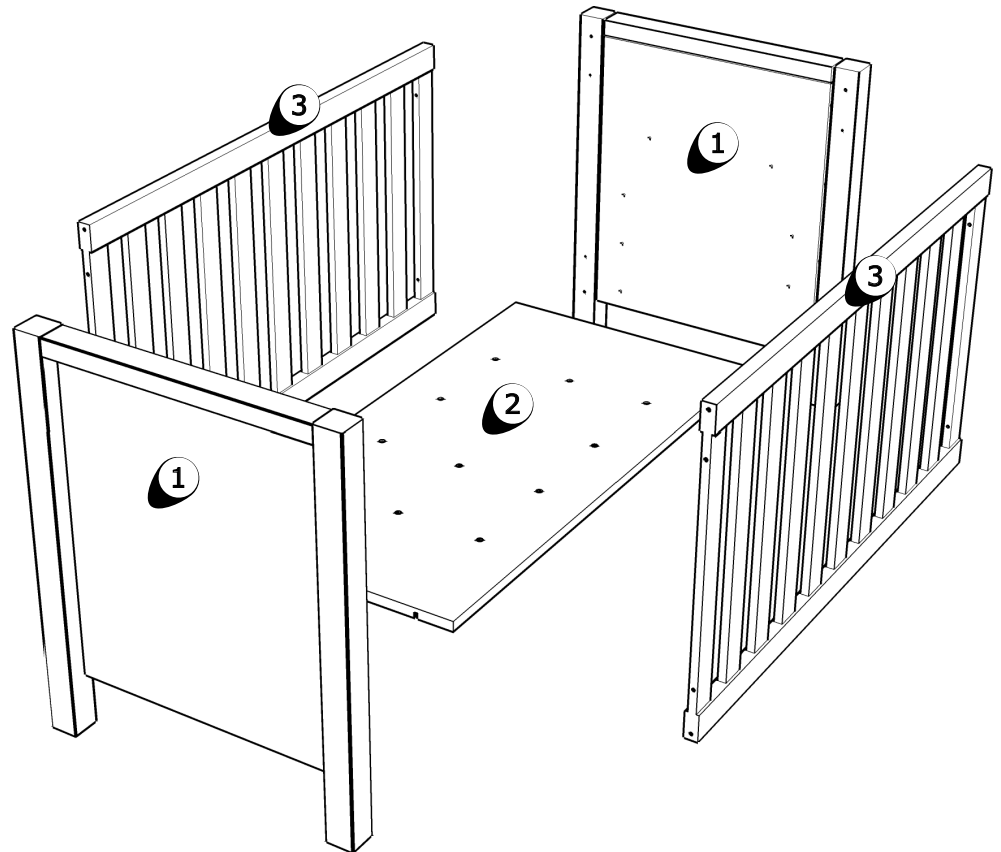
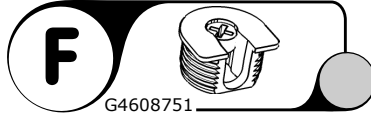
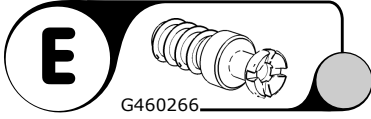
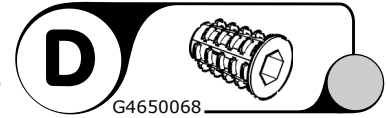
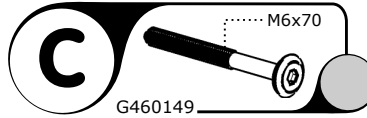
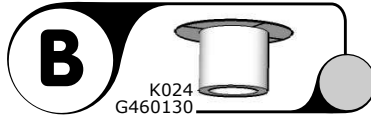
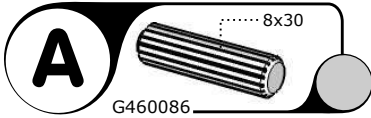
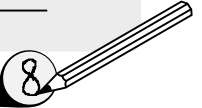

1 HBB101

2 T5321864

3 G4807515

TOELICHTING EXPLICATIONS - EXPLANATION - ERKLARUNG

NL**ONDERHOUDSTIPS**

Oppervlakte kunststofdecor houtstructuur. Onderhoud: met lichte vochtige doek reinigen en hierna direct droog wrijven. De meubels zijn niet voor vochtige ruimten (bad, keuken etc.) bestemd. Vocht op het bovenblad direct opnemen. Montagetekening opbergen.

Het meubel moet door een vakkundig persoon, zoals in de handleiding staat beschreven worden gemonteerd. Door verkeerde montage kunnen gevaren ontstaan.

D**HINWEISE FÜR DIE PFLEGE**

Oberflächen Kunststoff-Dekor Holznachbildung. Pflegehinweis: Mit leicht feuchtem Tuch reinigen, sofort trocken nachwischen. Möbel nicht für Feuchträume geeignet (Bad, Küche etc.). Nässe auf Oberfläche unverzüglich wegwischen. Aufbauanleitung aufbewahren.

Das Möbel muss durch eine fachkundige Person entsprechend der Aufbauanleitung montiert werden. Bei fehlerhafter Montage kann es zu Gefahren kommen.

EN**ADVISE ON MAINTENANCE**

All surfaces in laminated wood colour finishes. Maintenance: clean with slightly moistened cloth, wipe dry immediately. Not suited for damp locations (kitchen, bathroom etc.). Wipe off wetness at once. Retain manual instruction.

The unit must be put together by a specialist according to the assembly instructions. Hazards may arise in case of incorrect assembly.

F**CONSEILS D' ENTRETIEN**

Panneaux de particules revêtus d'un film polymère. Entretien: utiliser un chiffon légèrement humide et repasser de suite avec un autre sec. Meuble inadapté aux pièces humides (bain, cuisine etc.). Toute trace de liquide est à essuyer immédiatement. Notice de montage à conserver.

Le meuble doit être monté par une personne spécialisée en la matière, conformément à l'instruction de montage. En cas d'erreur de montage, des dangers peuvent se manifester.

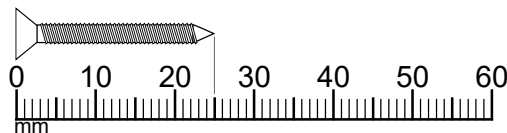
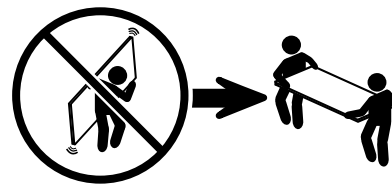
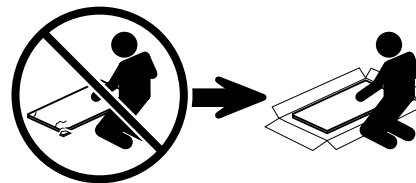
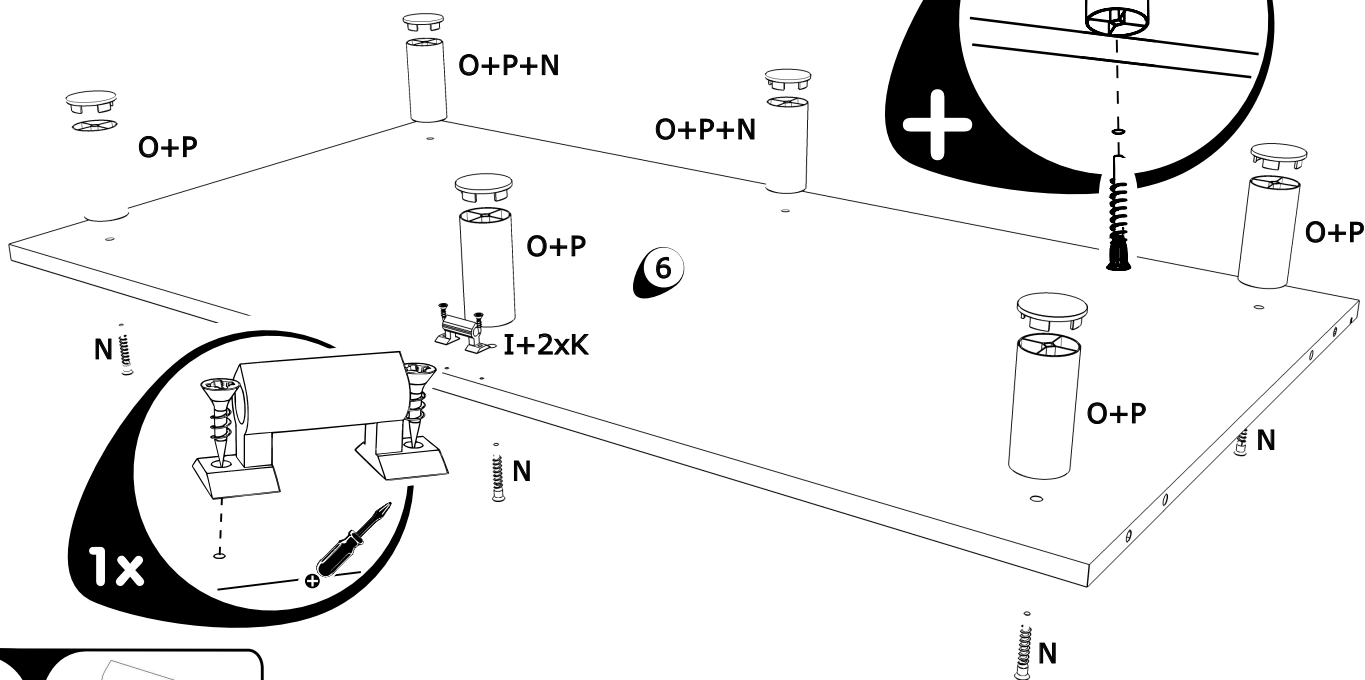
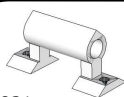
**1****I****1**

G4608831

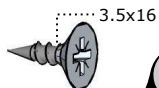
K**2**

G470013

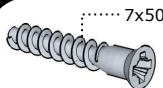
N**6**

G4600781

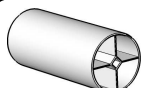
O**6**

G4401258

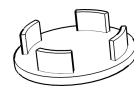
P**6**

G4401256

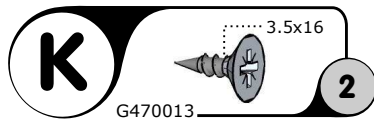
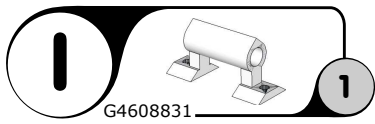
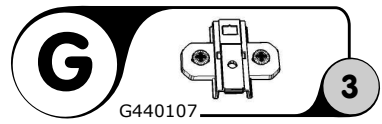
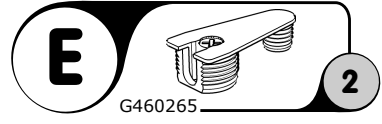
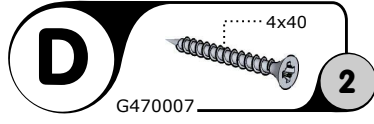
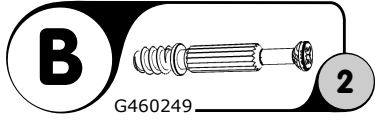
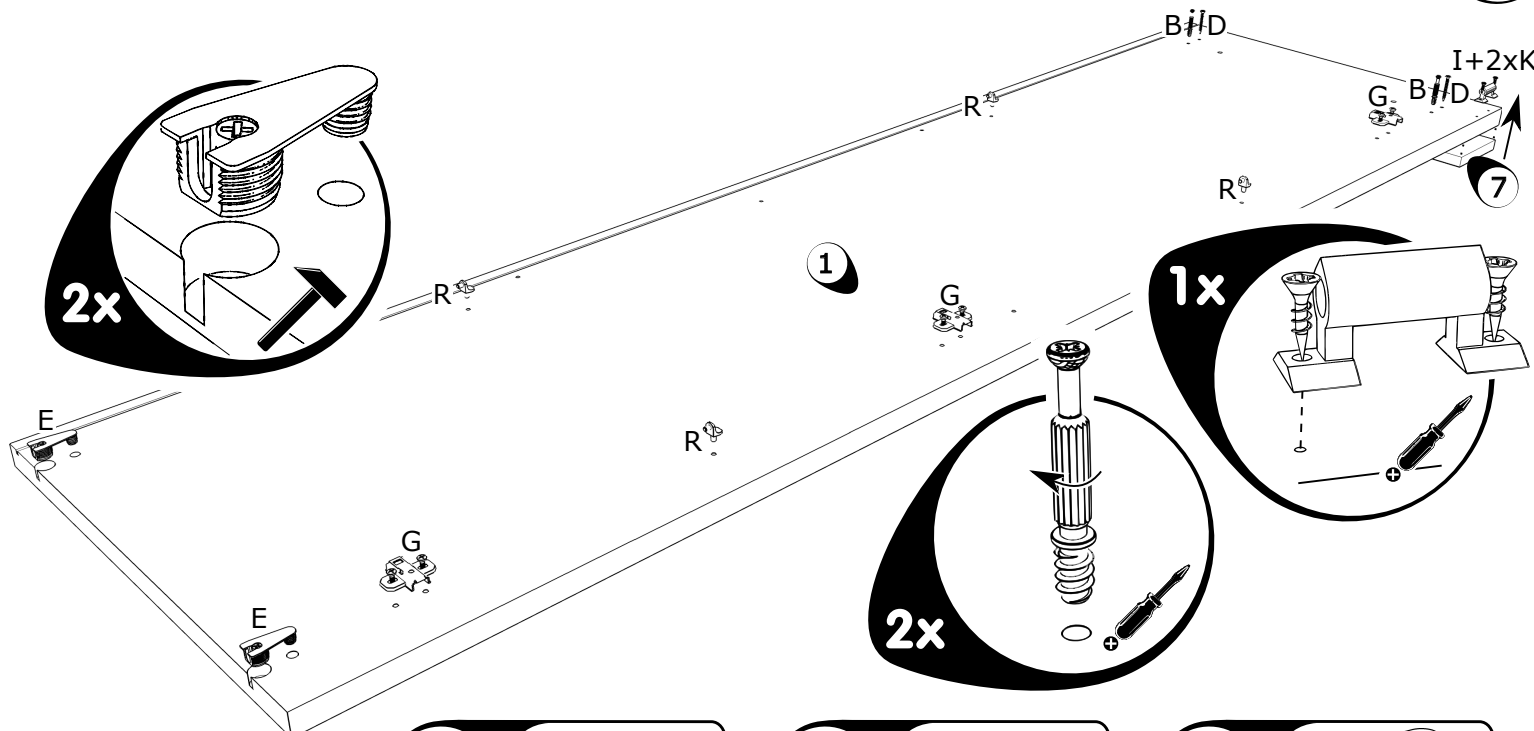
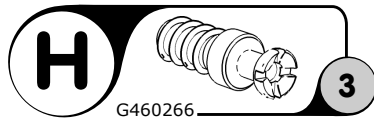
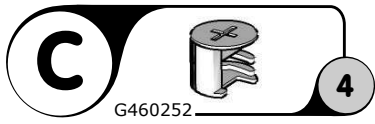
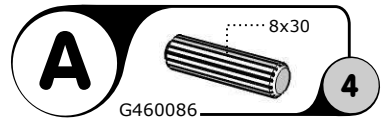
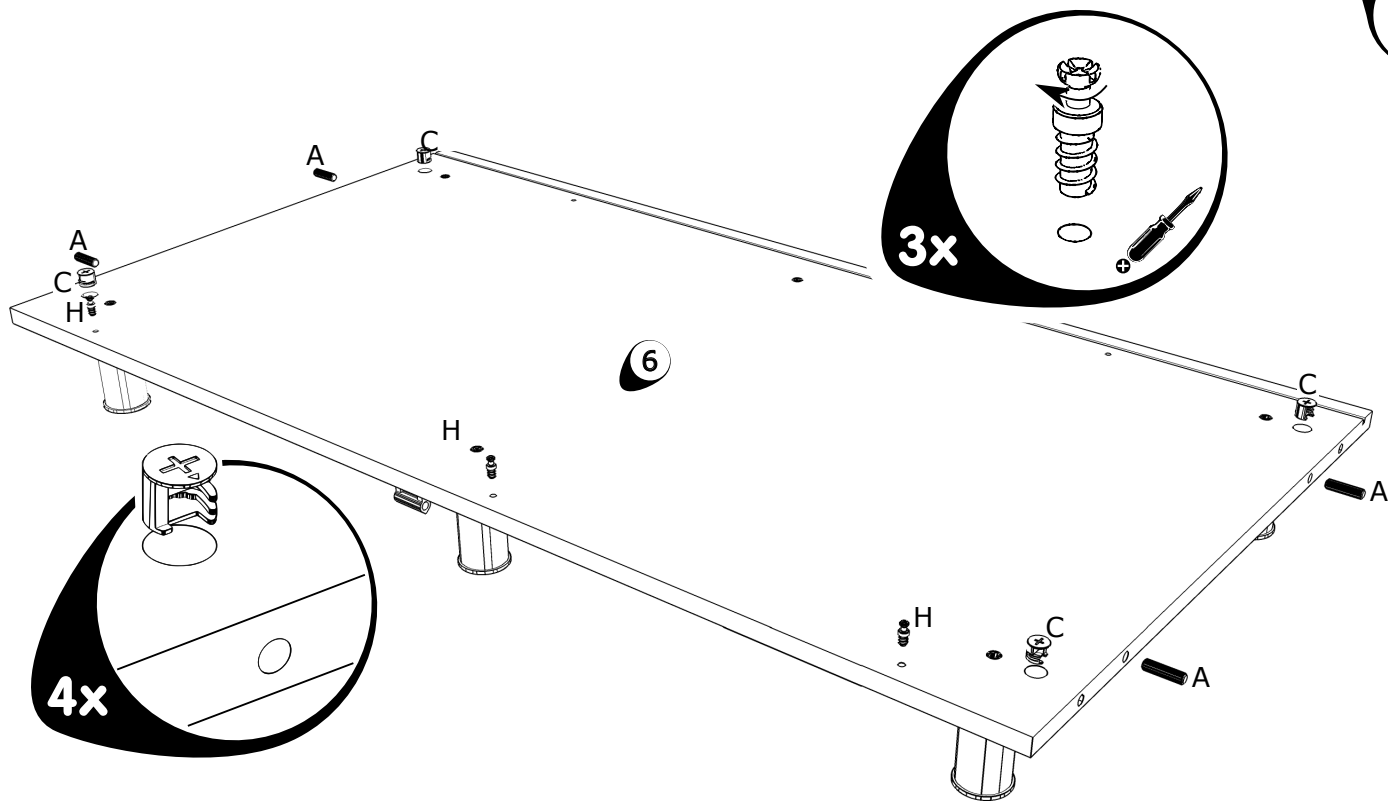

4

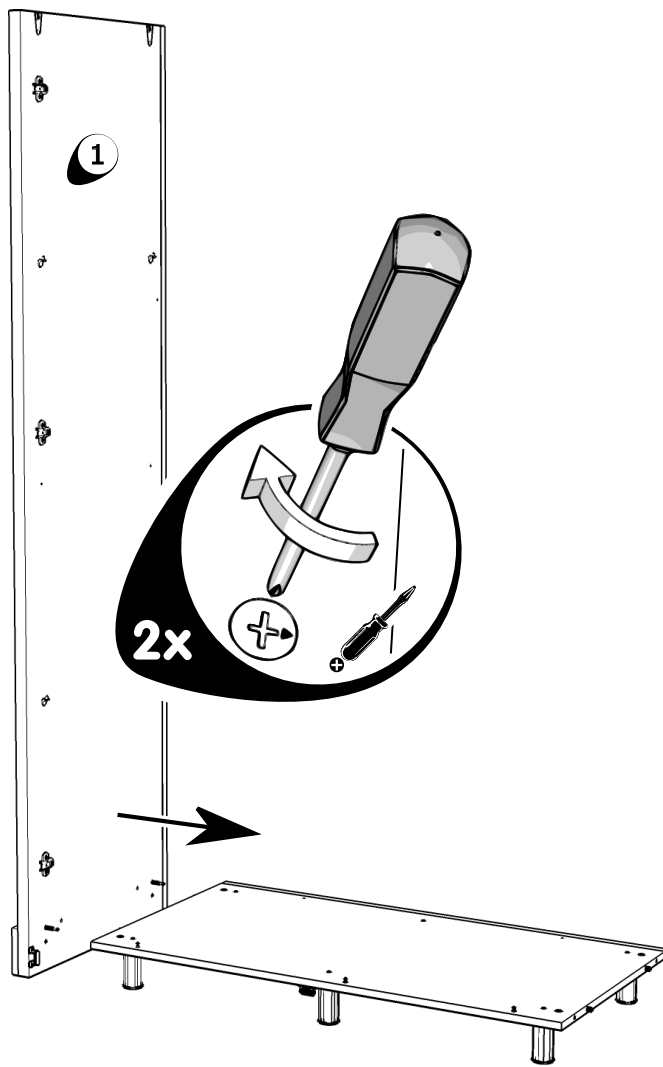

5

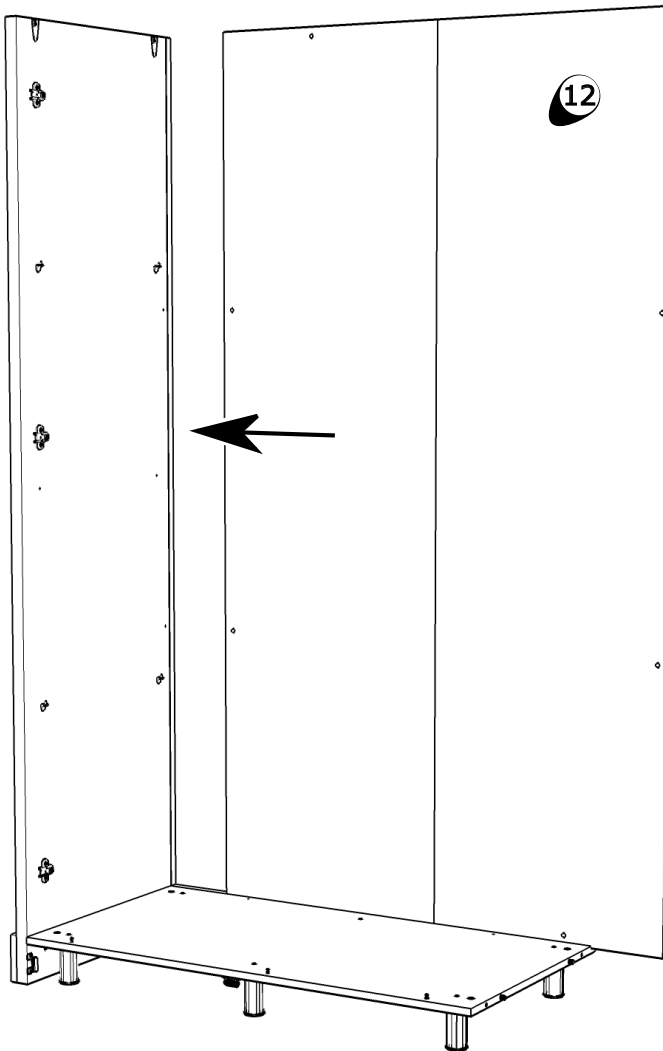

8

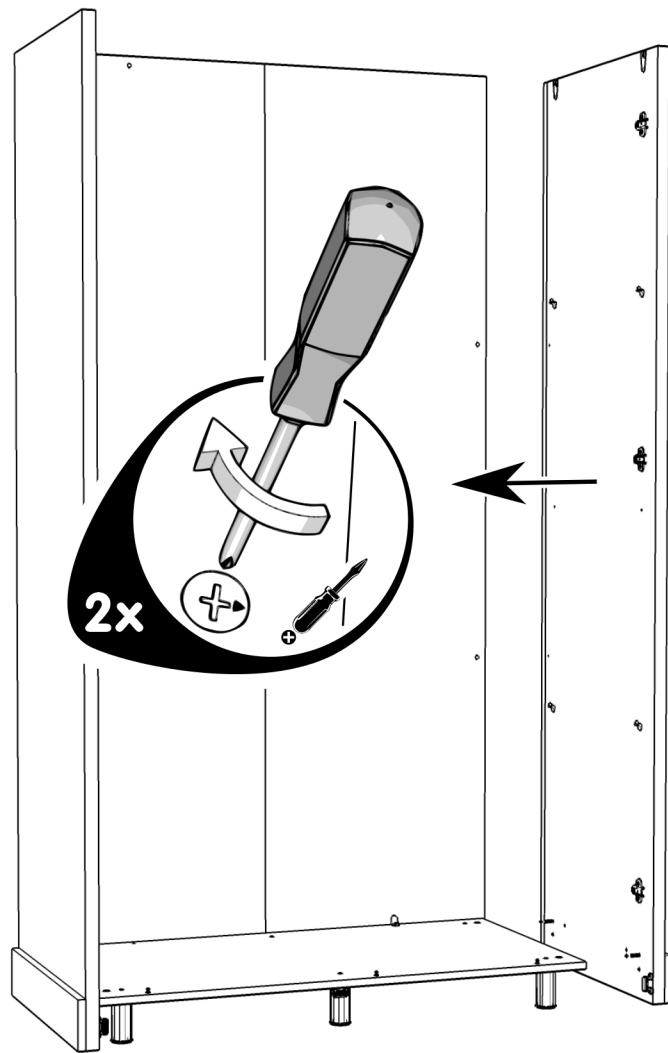

9

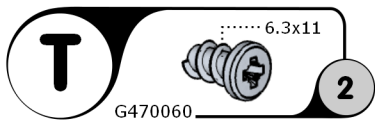
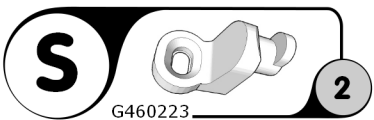
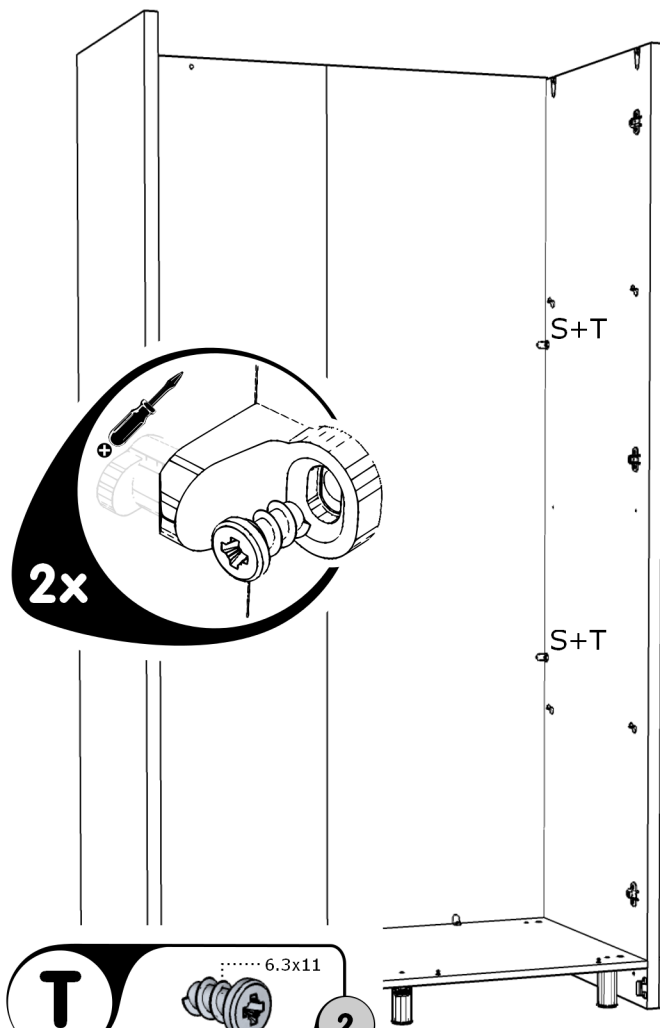

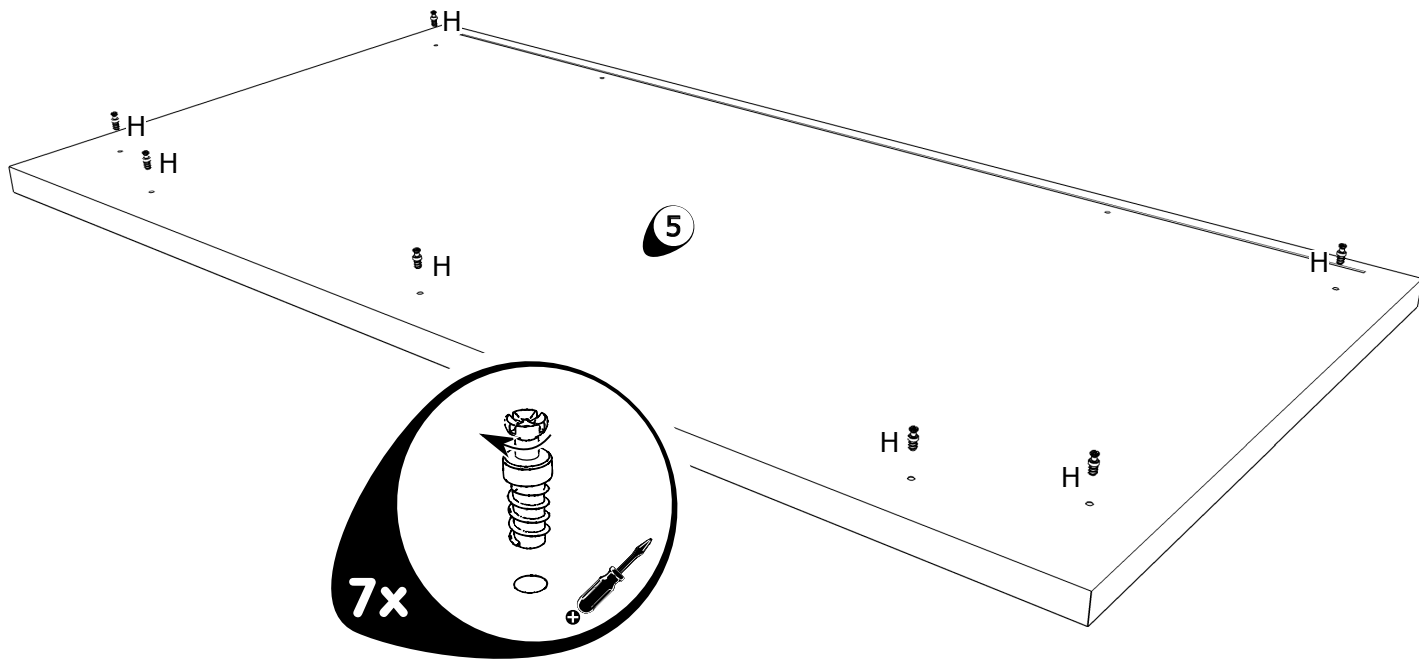

7x

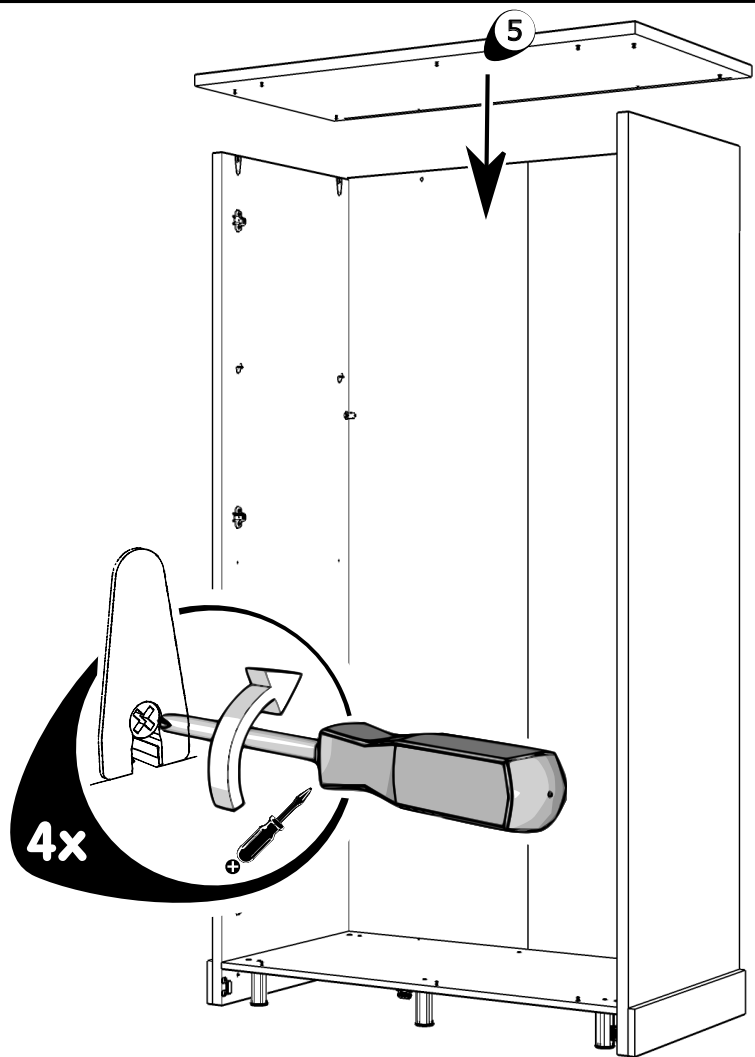
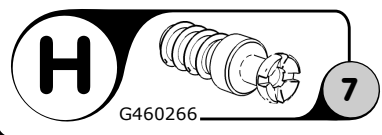

4x

12

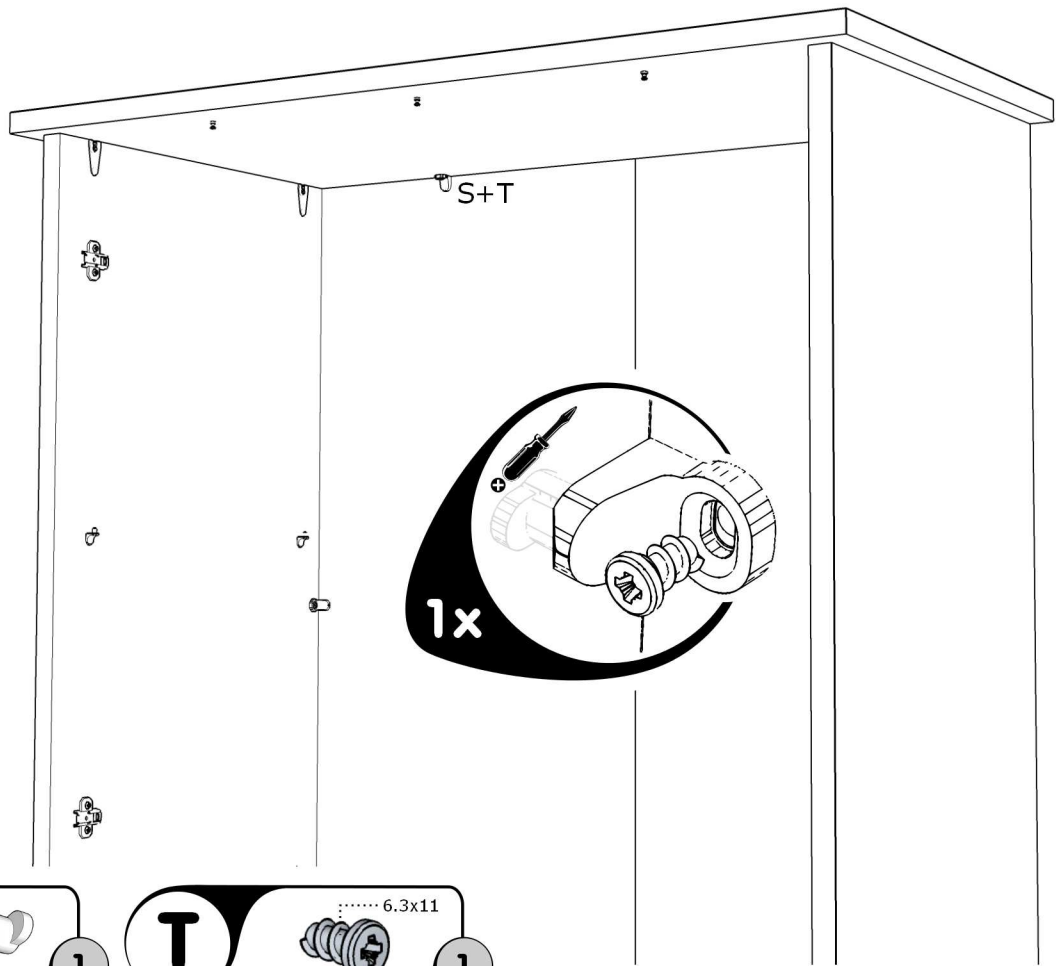

S G460223 **1**

T 6.3x11 **1**

13

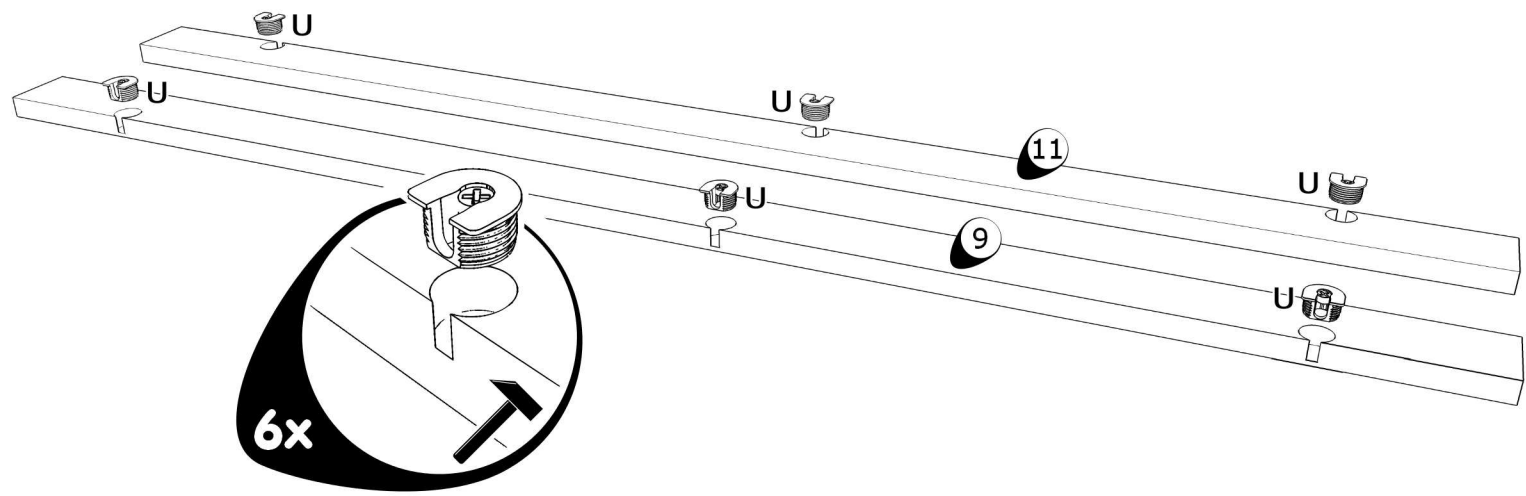

U G4750056 **6**

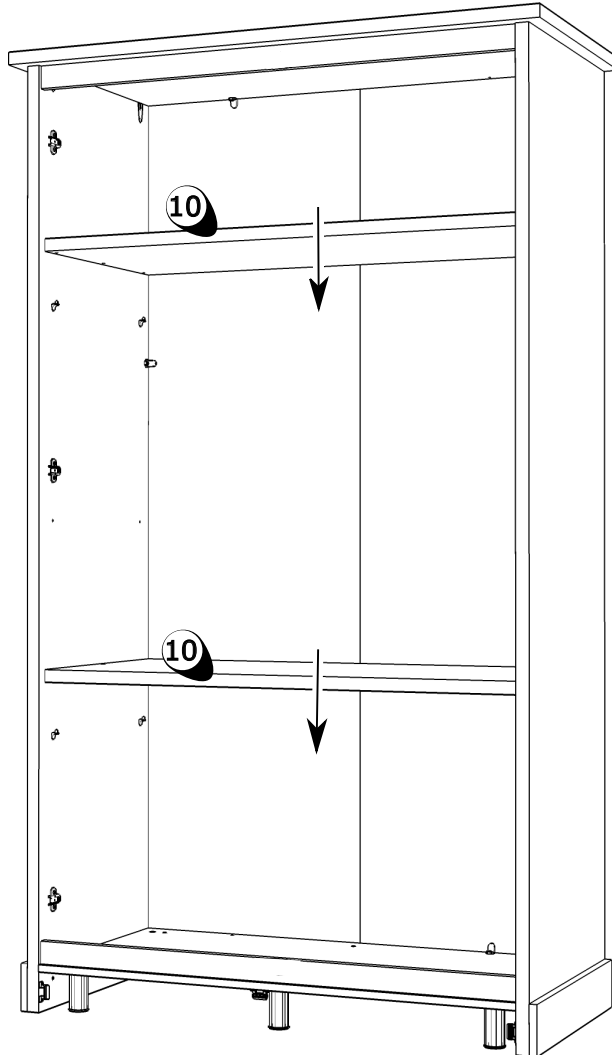
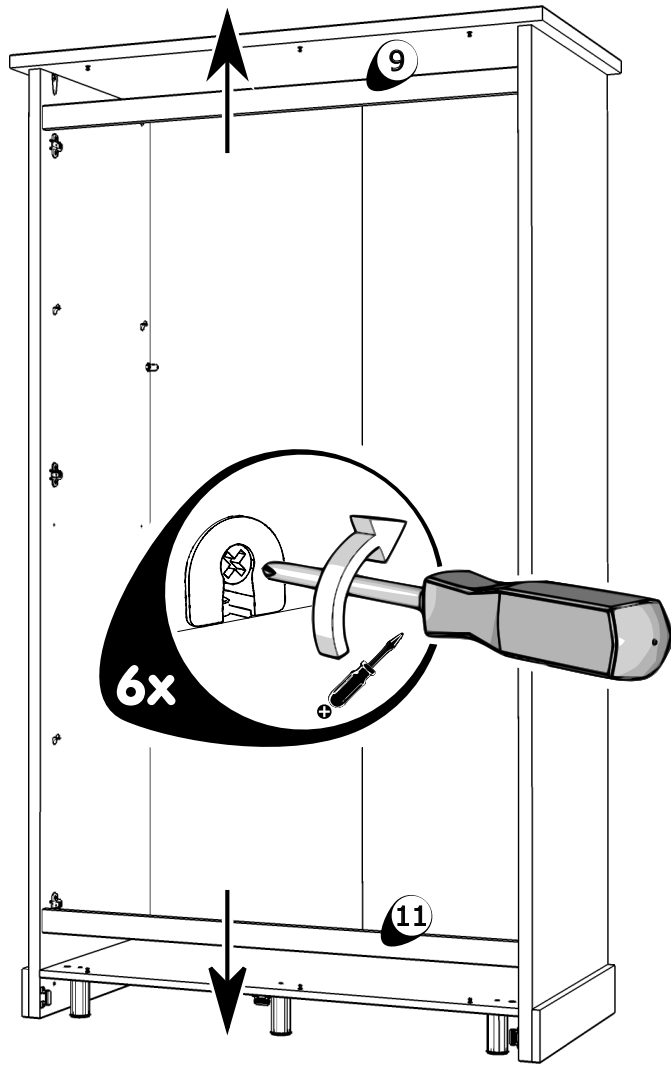

16

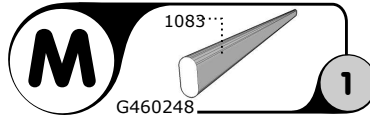
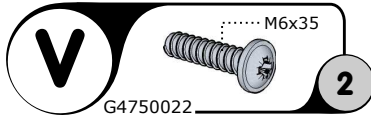
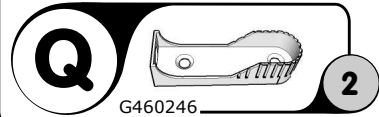
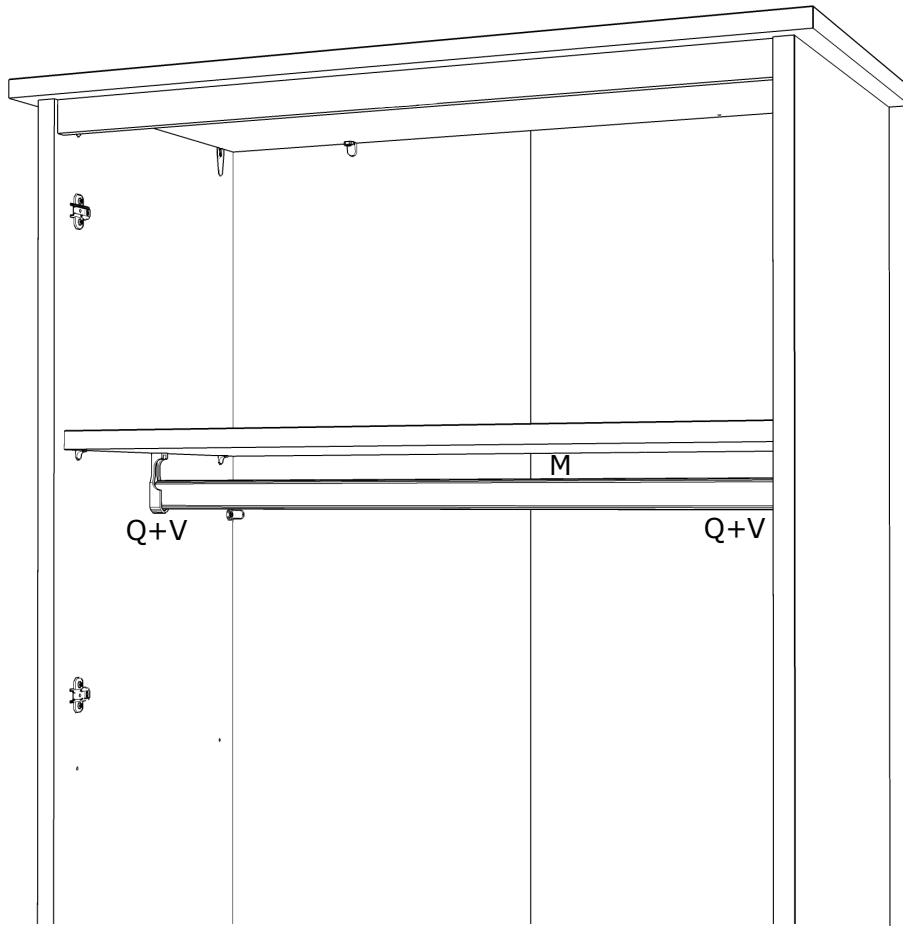

17

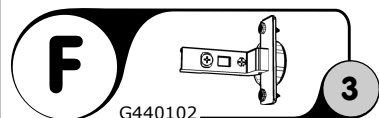
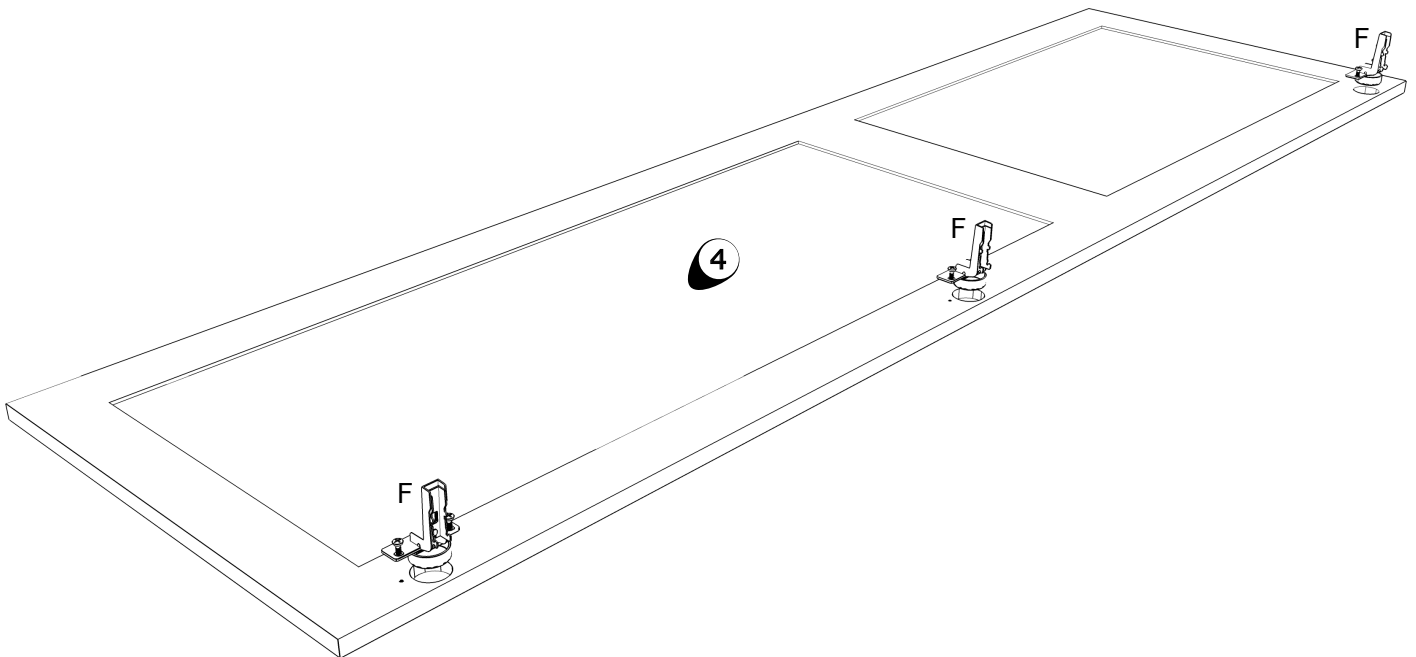

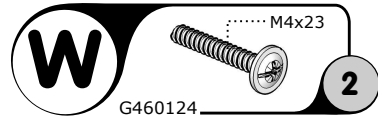
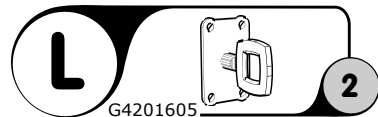
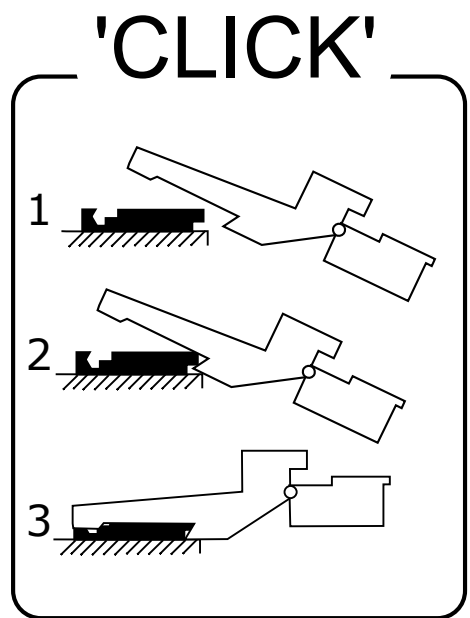
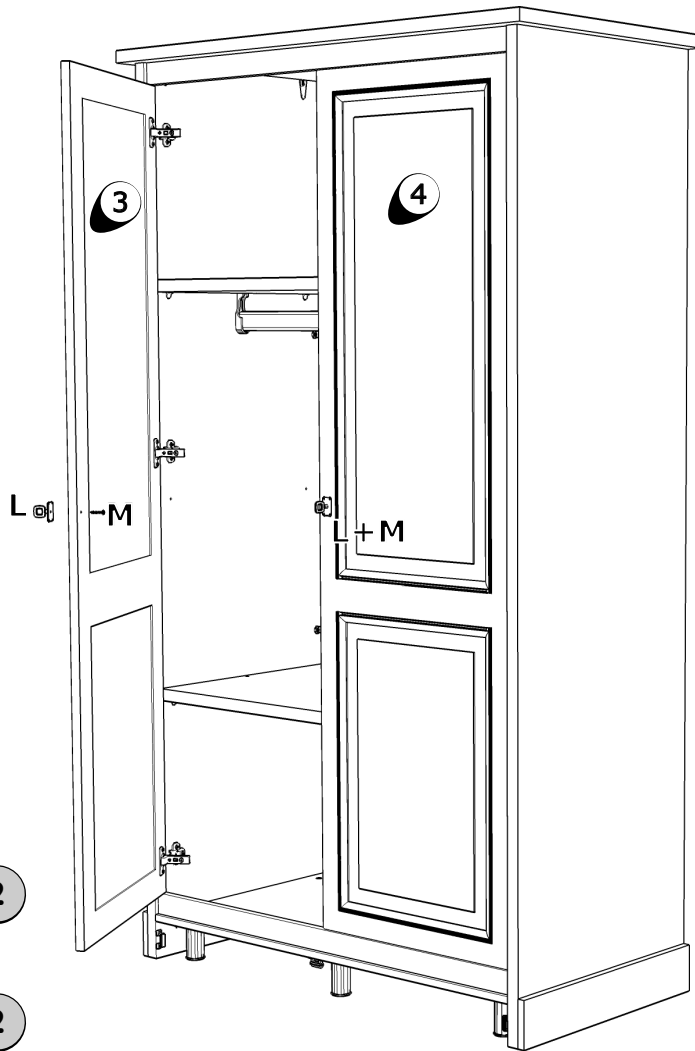
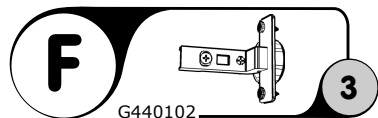
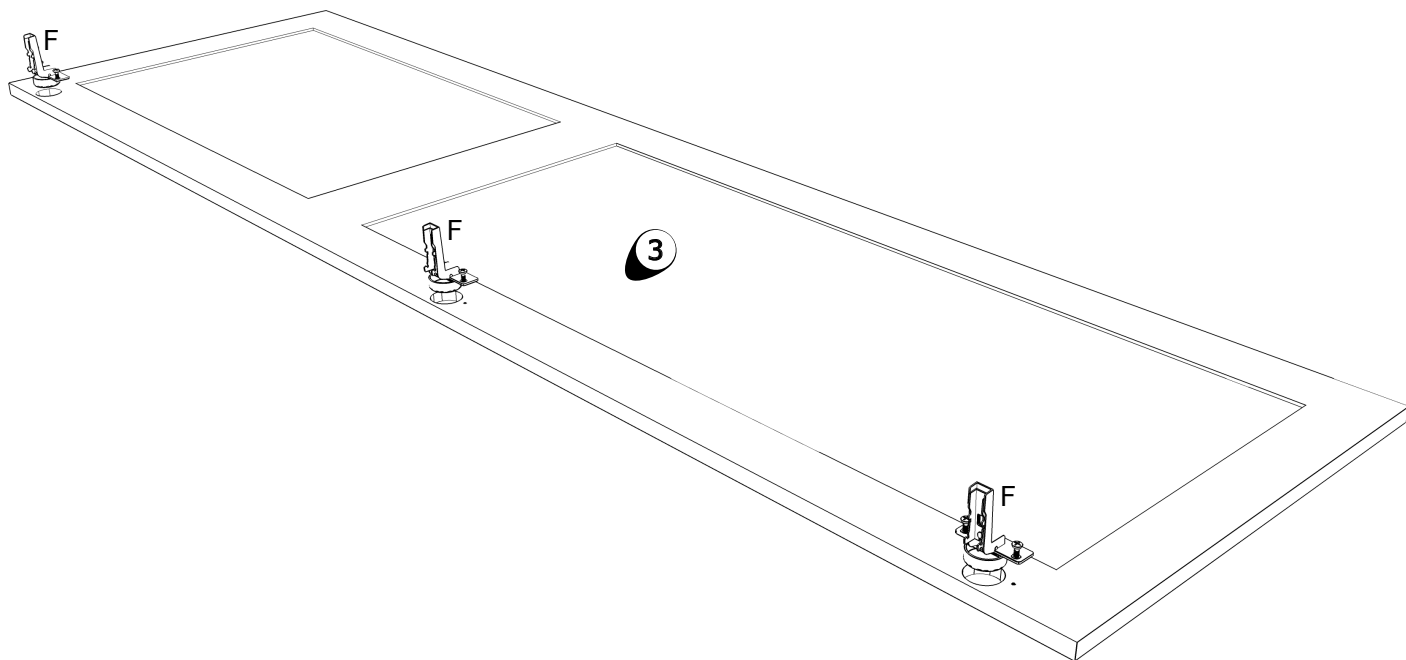

20

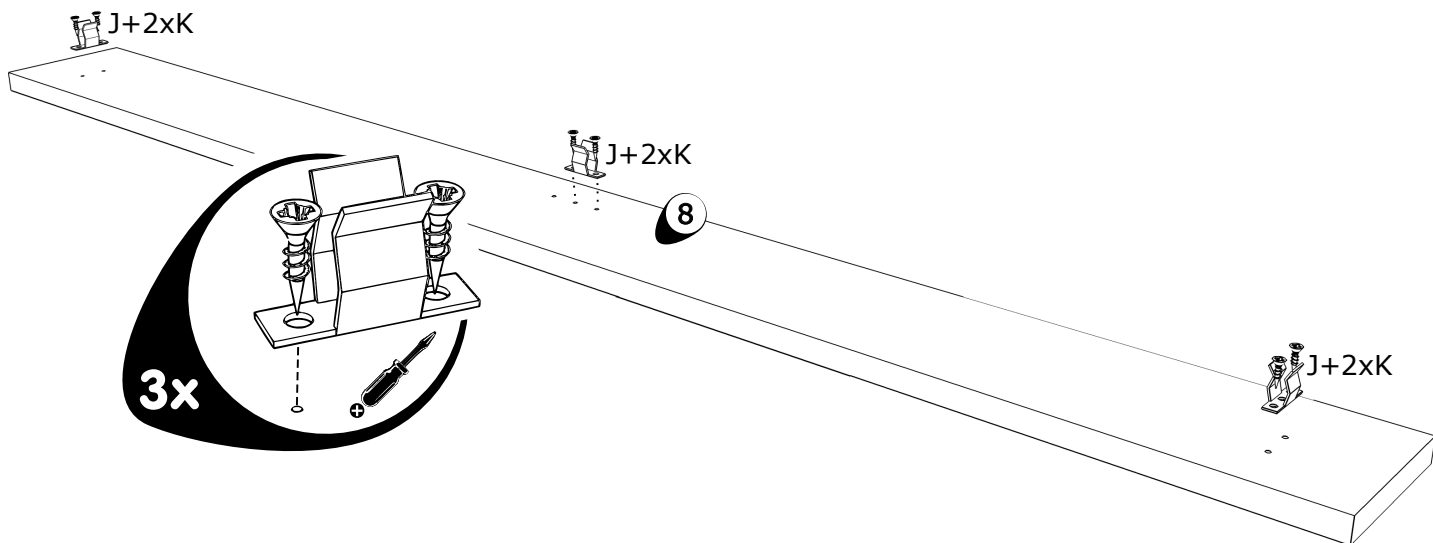

J

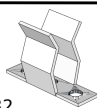

3

G4608832

K

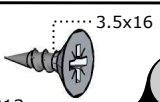

6

G470013

21

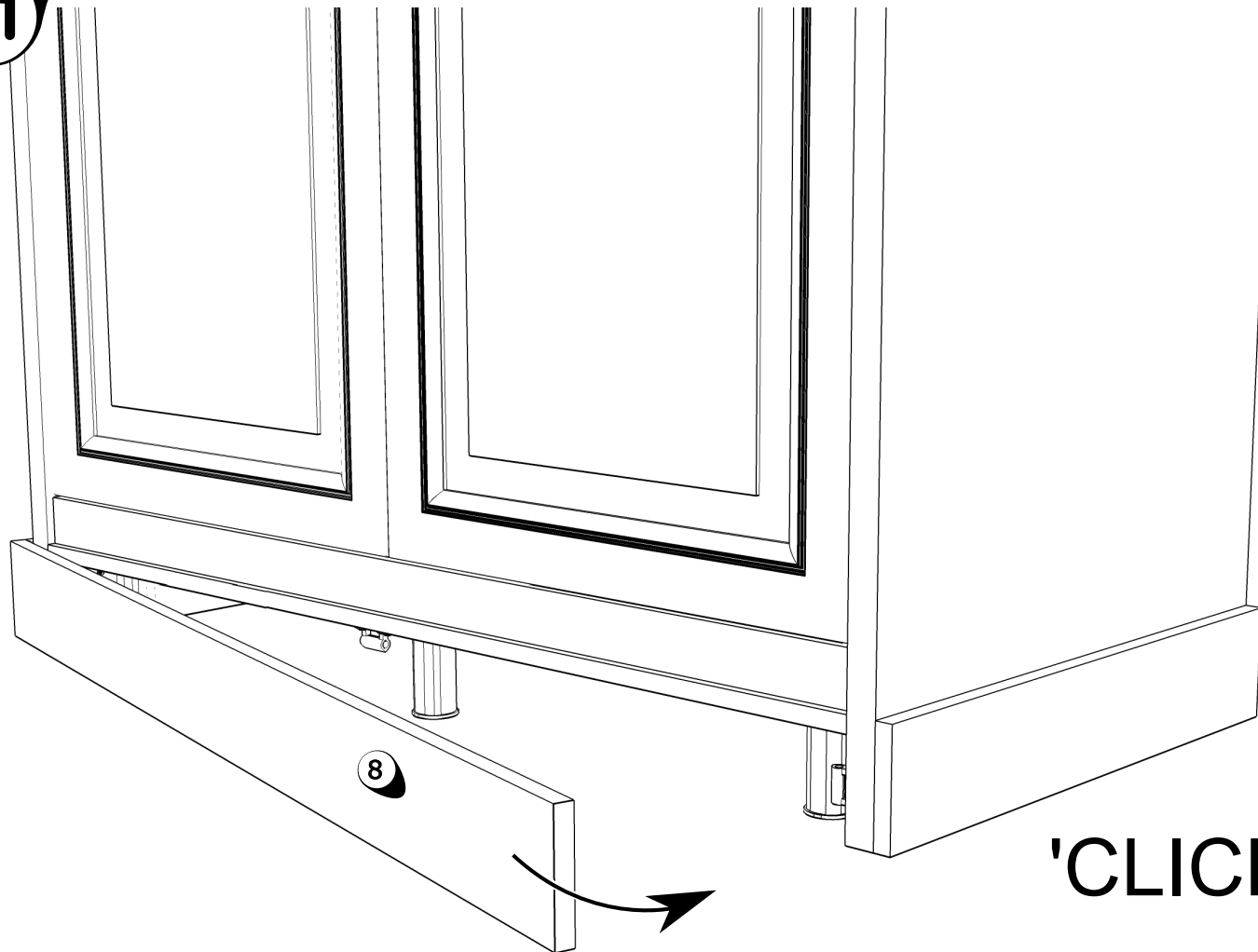

GEGEVENS AANKOPER

INFORMATIONS ACHETEUR - BUYER INFORMATION - KAUFER INFORMATIONEN

WINKEL

MAGASIN - SHOP - GESCHÄFT

PLAATS

LIEU - TOWN - ORT

AANKOOPDATUM

DATE DE L'ACHAT - DATE OF PURCHASE - KAUFDATUM

REFERENTIE

REFERENCE - REFERENCE - REFERENZ

KLEUR

COULEUR - COLOR - FARBE

8

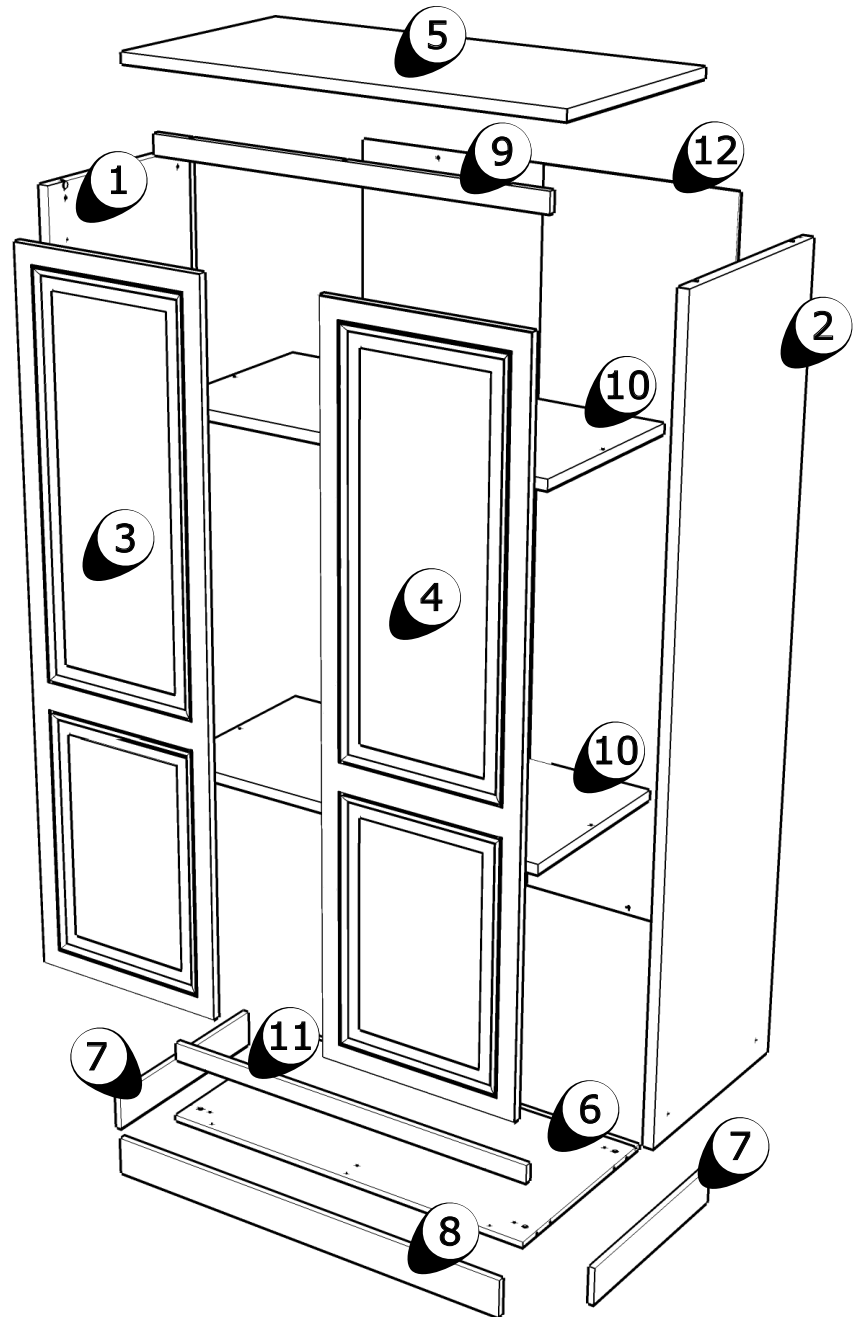

1 T5333110

2 T5322634

3 G4807732

4 G4807735

5 T5323379

6 T5323383

7 T5324504

8 T5324503

9 T5324517

10 T5322657

11 T5324516

12 G100974 L 2003 B1107

TOELICHTING EXPLICATIONS - EXPLANATION - ERKLÄRUNG

GEGEVENS AANKOPER

INFORMATIONS ACHETEUR - BUYER INFORMATION - KAUFER INFORMATIONEN

WINKEL

MAGASIN - SHOP - GESCHÄFT

PLAATS

LIEU - TOWN - ORT

AANKOOPDATUM

DATE DE L'ACHAT - DATE OF PURCHASE - KAUFDATUM

REFERENTIE

REFERENCE - REFERENCE - REFERENZ

KLEUR

COULEUR - COLOR - FARBE

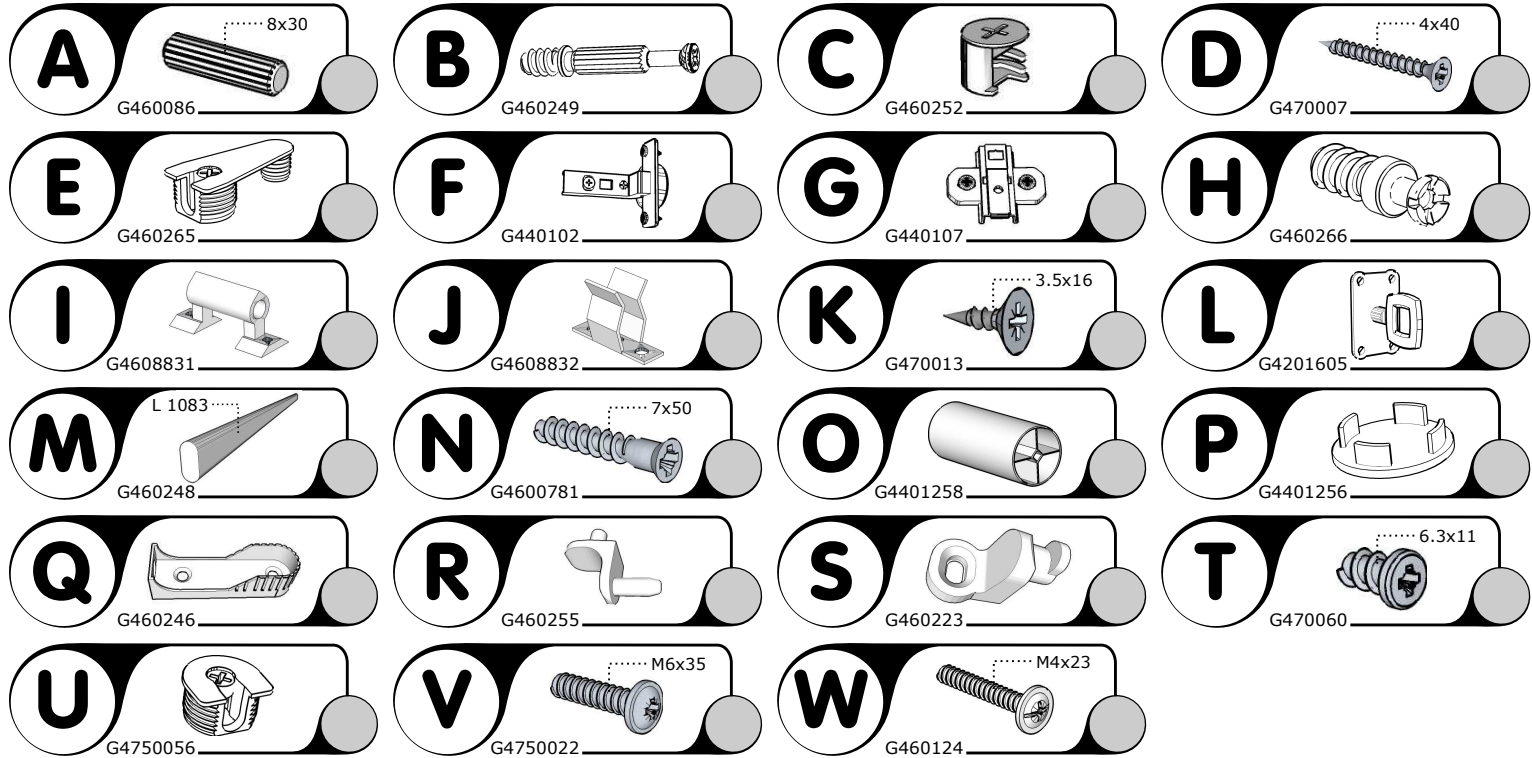
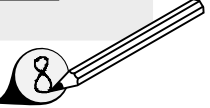

TOELICHTING EXPLICATIONS - EXPLANATION - ERKLÄRUNG

Blank area for providing explanations or instructions in multiple languages.