









ASSEMBLY INSTRUCTION

MODEL: 9001 SIDE TABLE

Before you begin, please follow Assembly Instruction carefully.
Then follow them step by step.

HARDWARE		LIST	
NO	DESCRIPTION		QTY
I	JCBC 2 layer M6 x 45 SCREW		4pcs
II	ALLEN KEY		1 pc
III	M8 x 32 CHIPBOARD SCREW		8pcs
IV	PVC LEG & SCREW M4 x 25		4sets
V	NAIL		20pcs
VI	HANDLE & SCREW M3.5 x 30		2sets
VII	Q-FIT		12sets
VIII	DRAWER SLIDER & SCREW M3.5 x 12		2sets

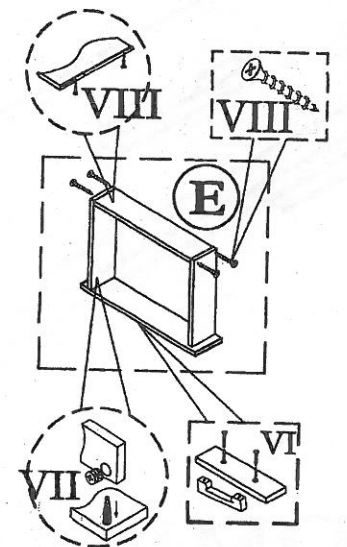
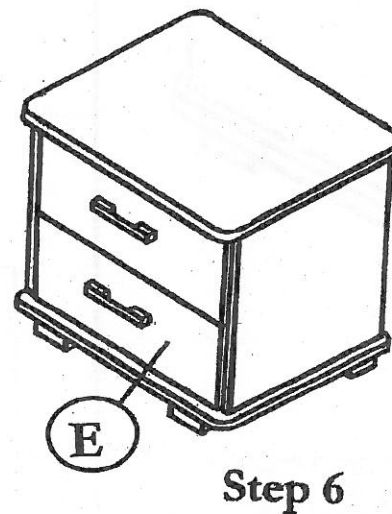
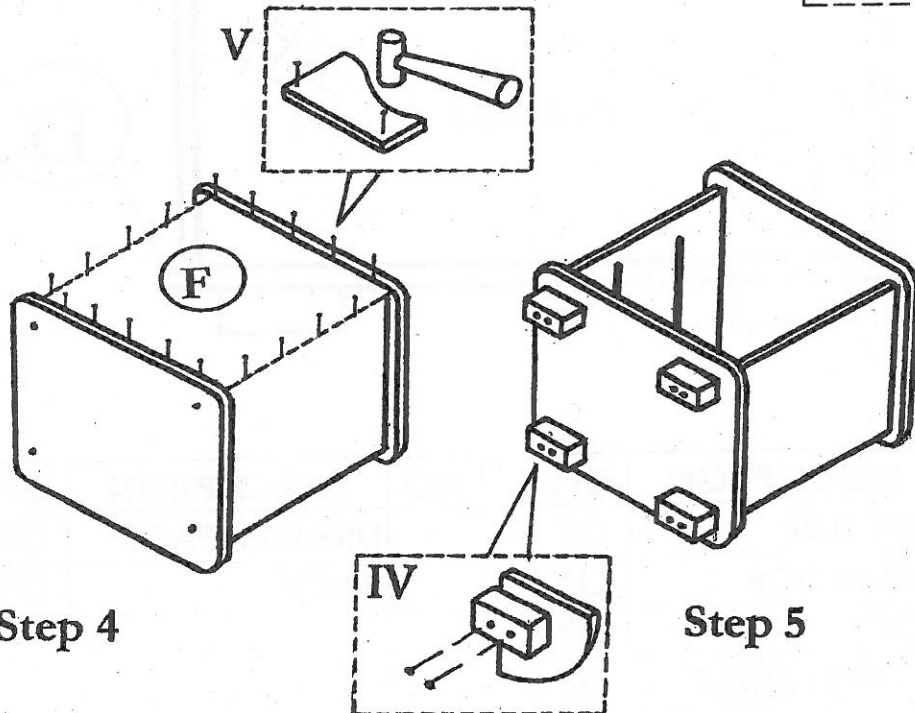
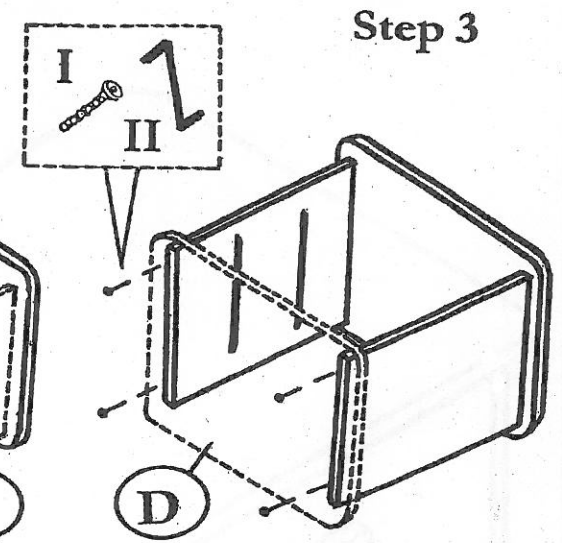
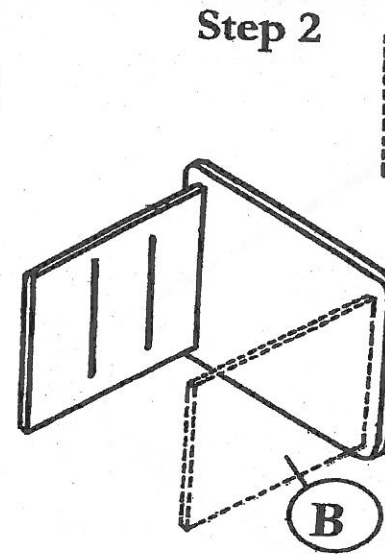
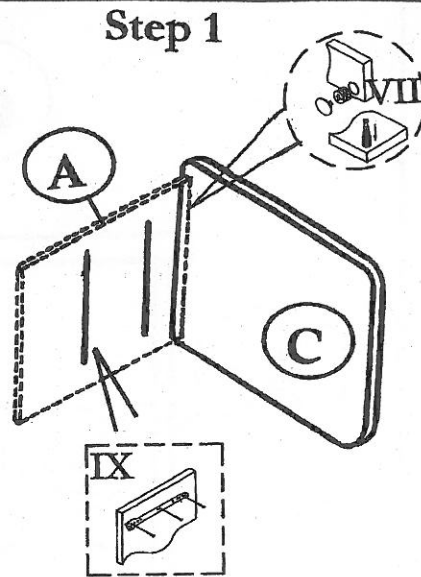

CAUTION:

To clean use soft, dry cloth. Do not use detergent or chemicals.
Avoid contact with water and direct sunlight.
To be assembled on a soft,dry, clean and smooth surface.

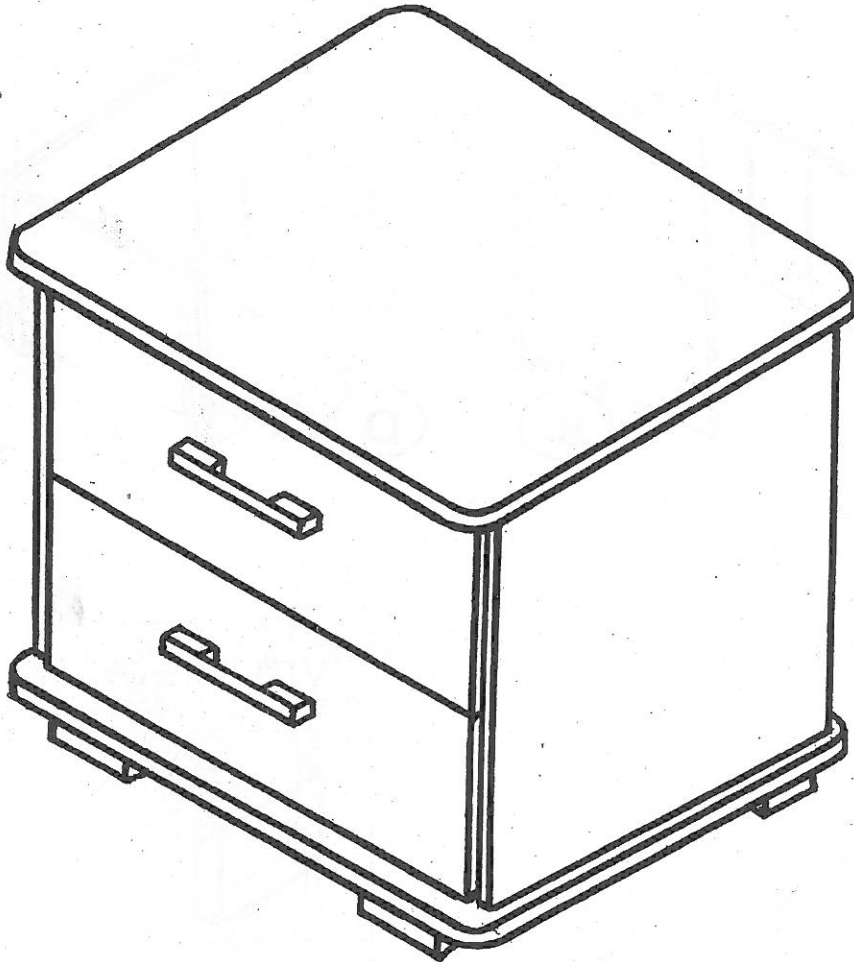

COMPLETE SET

ORDERING REPAIR PARTS

In order to obtain smooth and rapid service when ordering repair parts, please give full attention to the following of PART NUMBER.

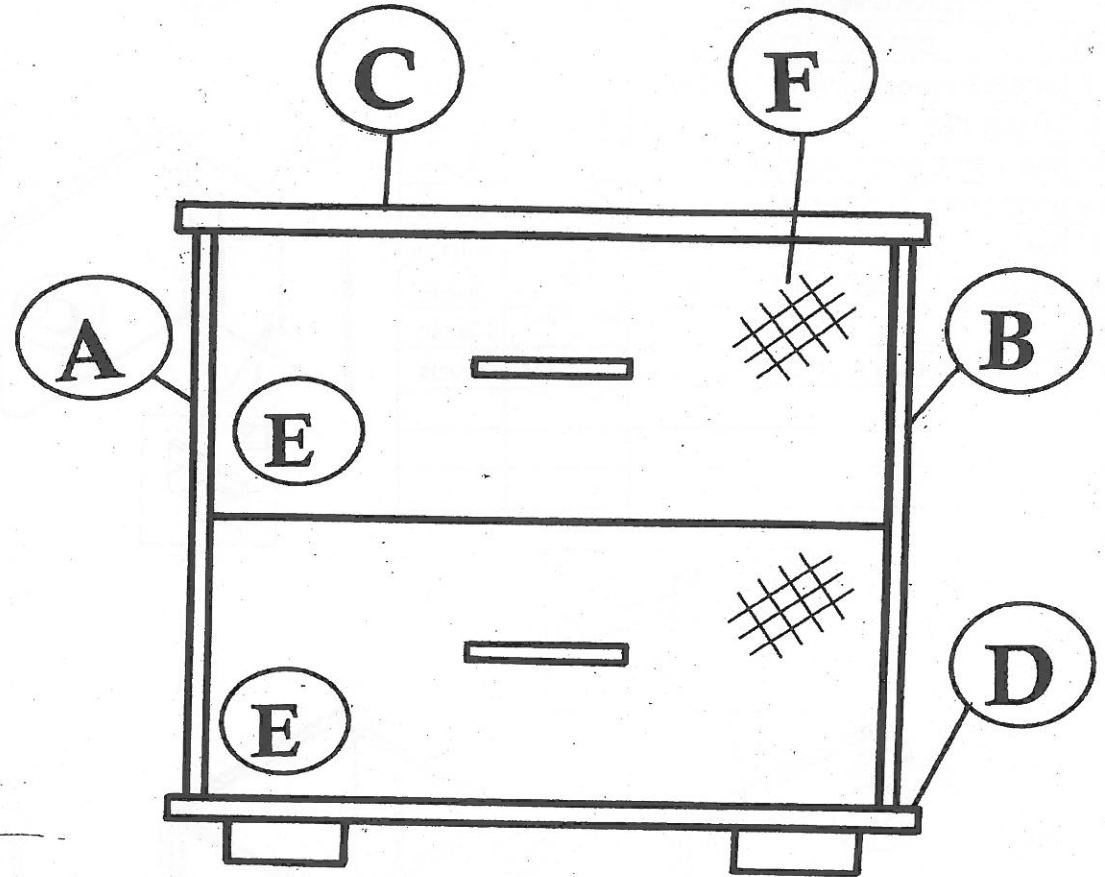

NO	DESCRIPTION	QTY
A	LEFT SIDE	01
B	RIGHT SIDE	01
C	TOP	01
D	LOWEST SHELF	01

NO	DESCRIPTION	QTY
E	DRAWER FACE	02
F	BACK	01