

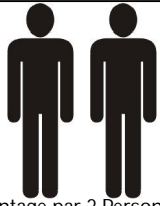

# Margot

Nachttafel  
Chevet  
Night Table

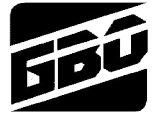

Montage par 2 Personnes  
Asembly by 2 Persons  
Opbouw met 2 Personen

Gebruik deze handleiding van begin tot einde voor het probleemloos monteren van uw aangekocht meubel aub..

Veuillez bien suivre nos instructions ci-après lors du montage de votre meuble. Merci.

Please use the manual from the beginning until the end to assemble your newly bought furniture without troubles.

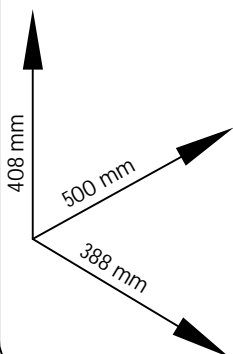
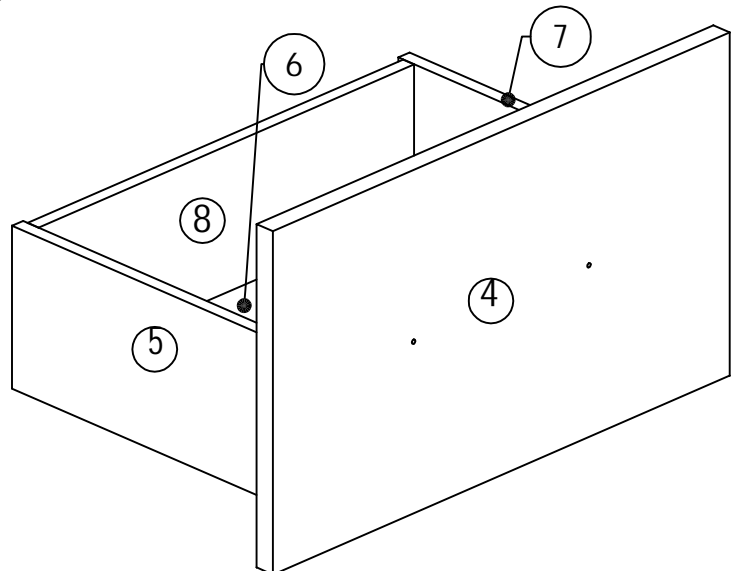
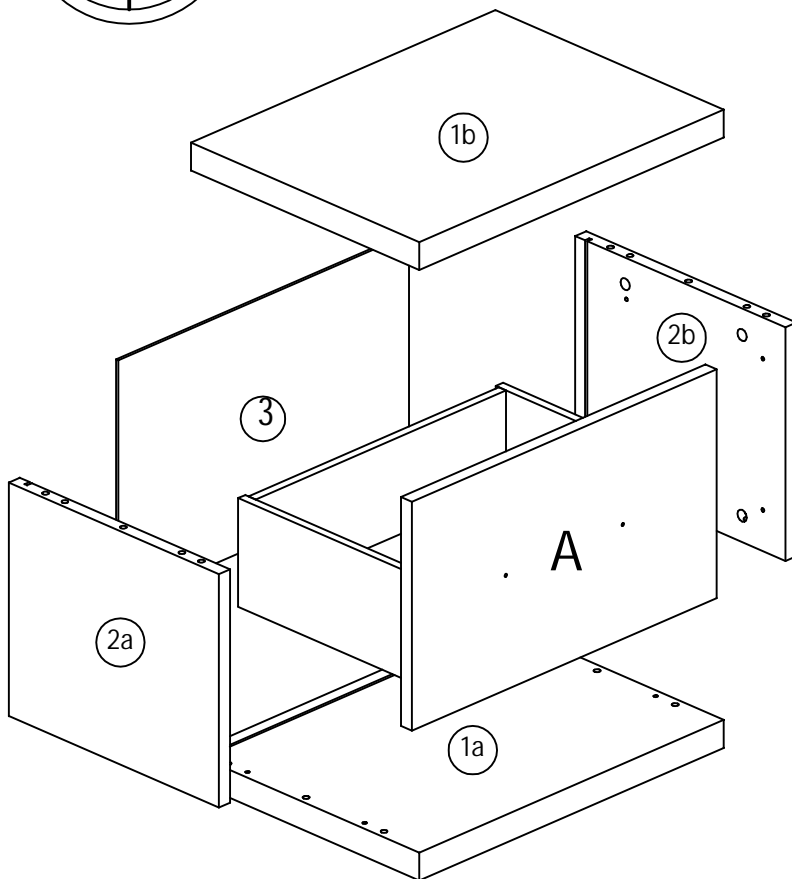
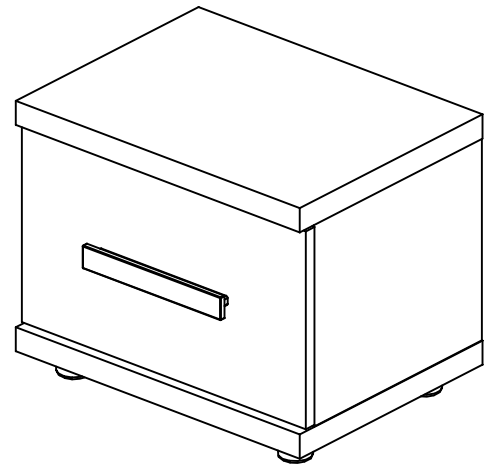

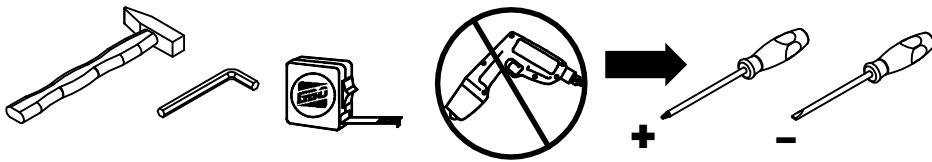

**FR** Entretien: utilisez un chiffon légèrement humide et séchez aussitôt. Toute trace de liquide doit être enlevé immédiatement. Meuble inadapté aux pièces humides. N' utilisez jamais du solvant, détergent, diluant, produits chimiques ou cirage. Notice du montage à conserver. Pour tous service apres-vente, rendezvous au magasin avec cette notice.

**GB** Maintenance: clean with slightly wet moistened cloth, wipe dry immediately. Wipe off wetness at once. Not suited for humid locations. Never use Solvent, cleaner, thinner, chemical products or wax. Retain manual instruction. For the after sales, go back to the shop with this assembly instruction.

**NL** Onderhoud: met licht vochtige doek reinigen hierna direct droog wrijven. Vocht op het bovenblad direct opnemen. De meubels zijn niet voor vochtige ruimten bestemd. Gebruik nooit Oplosmiddel, reinigingsmiddel, verdunner, chemische producten of boenwas. Montage tekening opbergen. Voor Service na verkoop, ga naar uw leverancier met deze montage handleiding.

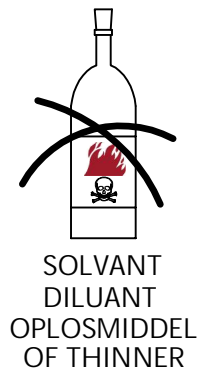

Karina\_BE9\_V1\_320812\_02-09

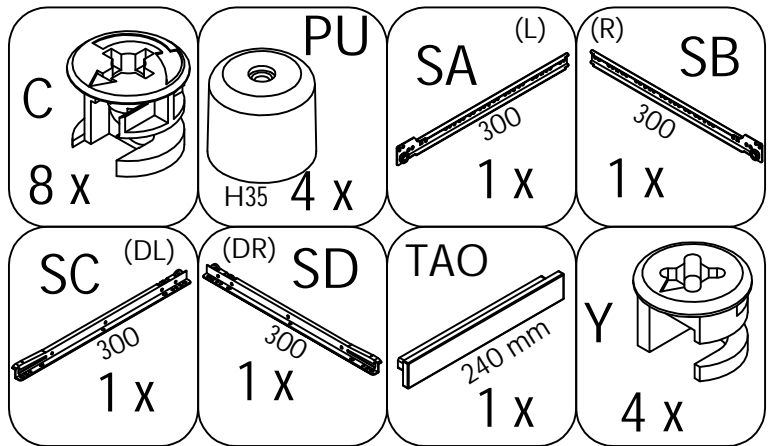
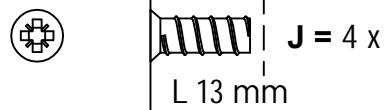
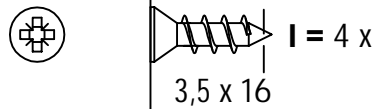
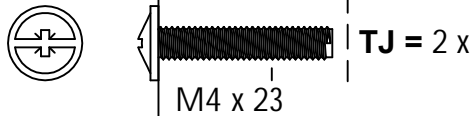
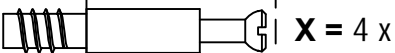
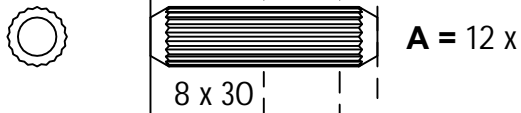
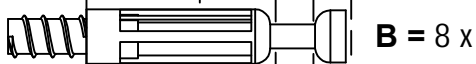
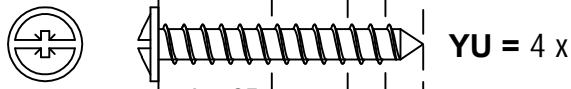
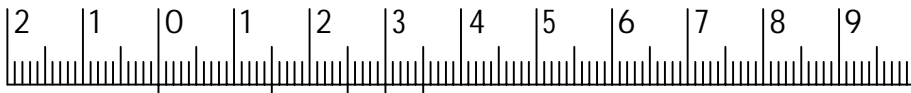
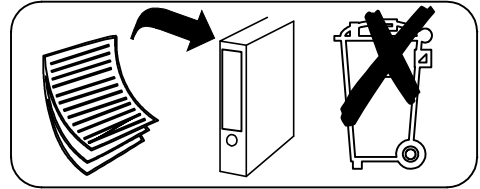
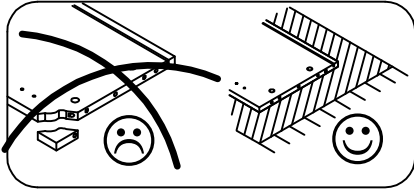

1

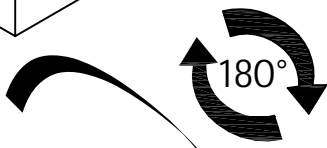
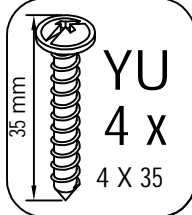
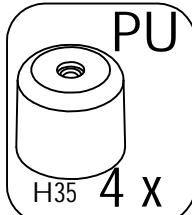
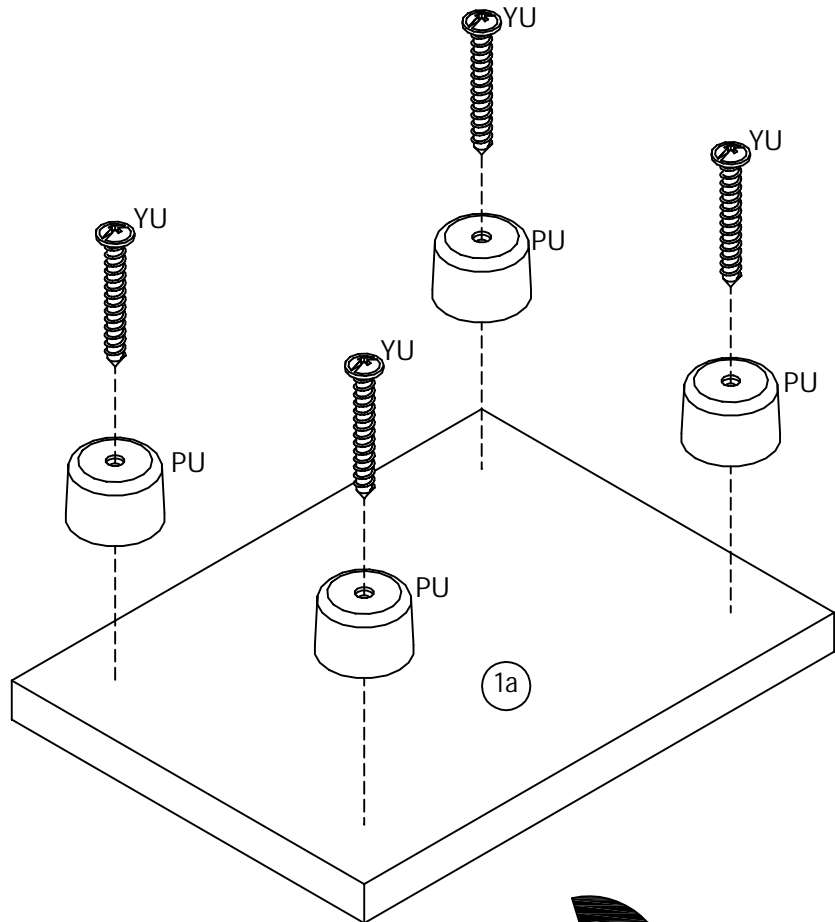

2

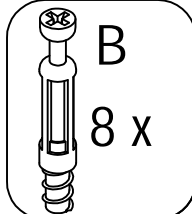
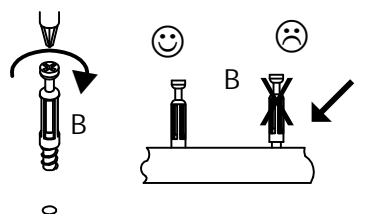
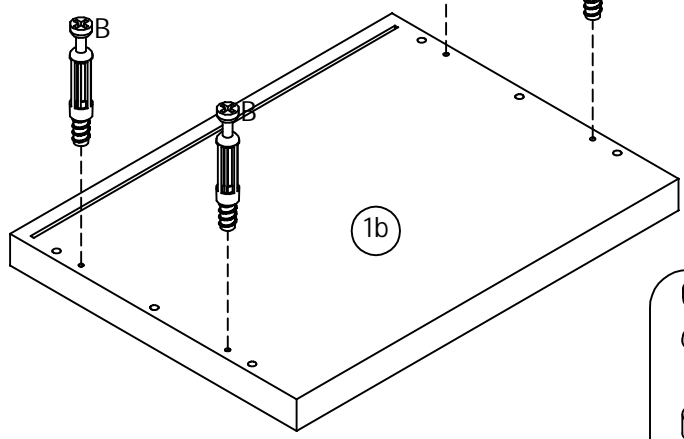
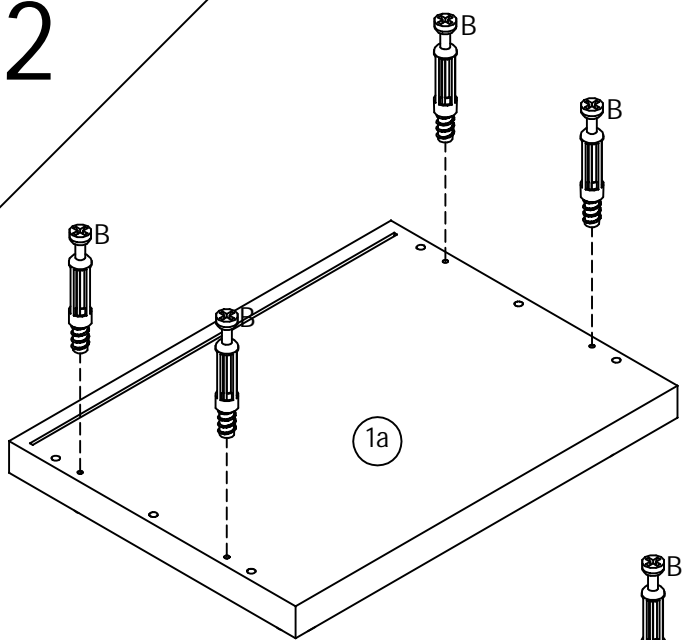

3

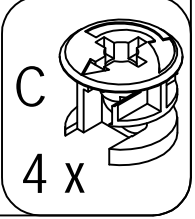
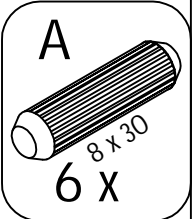
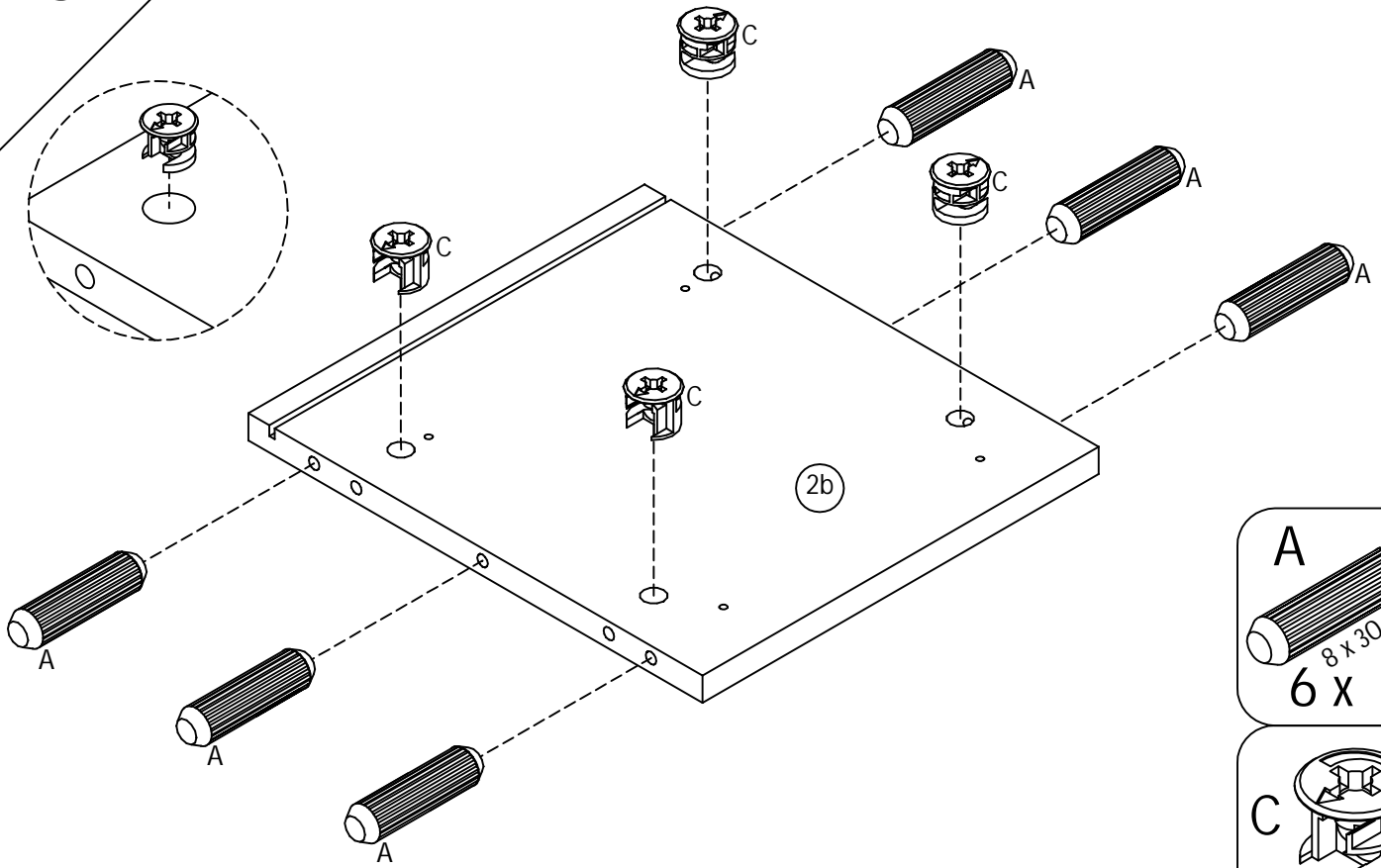

4

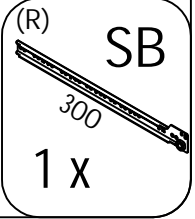
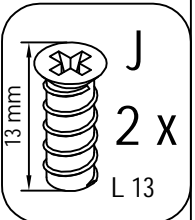
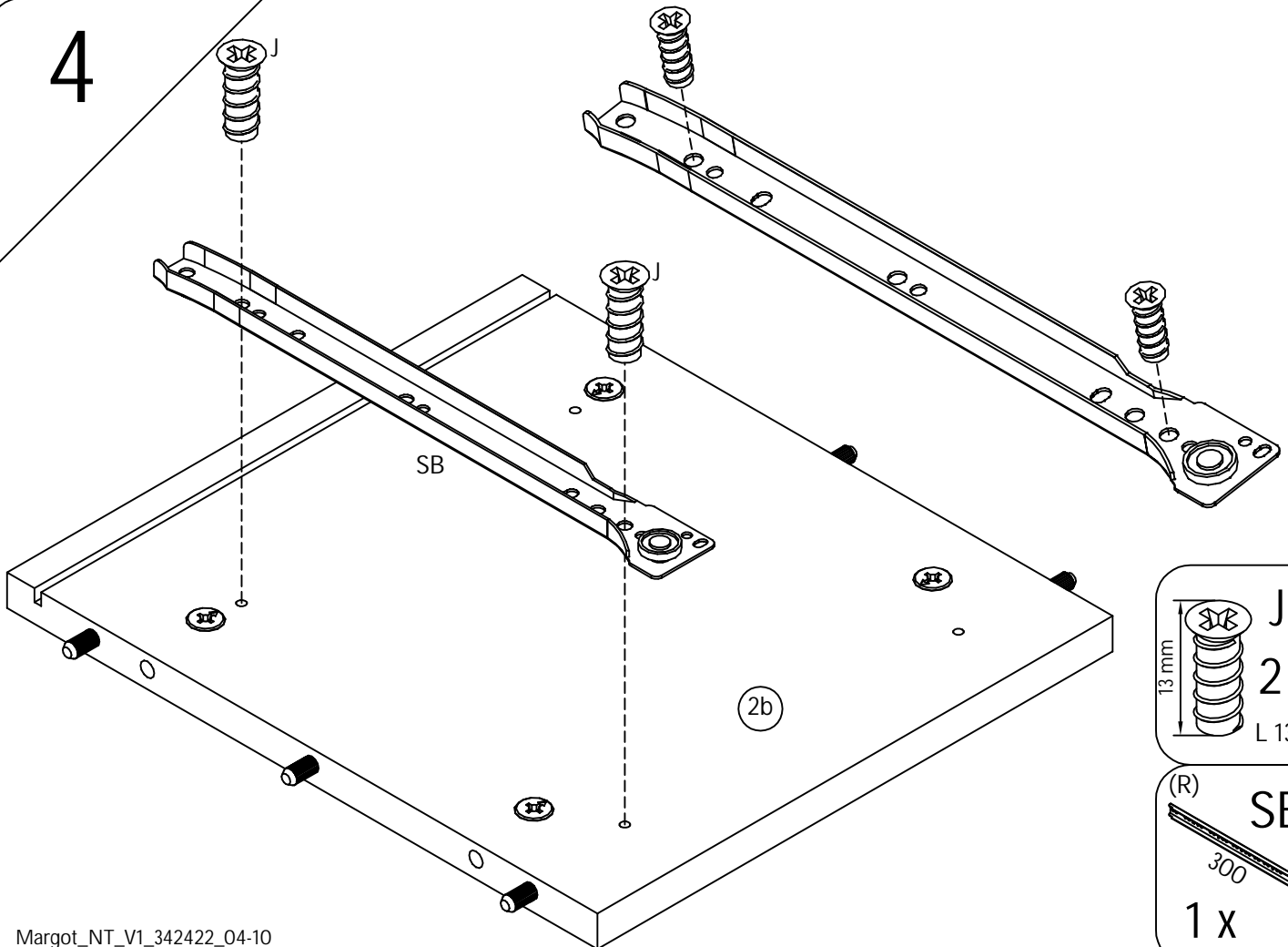

5

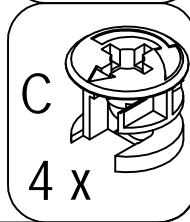
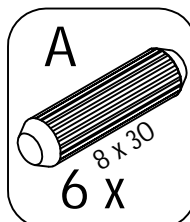
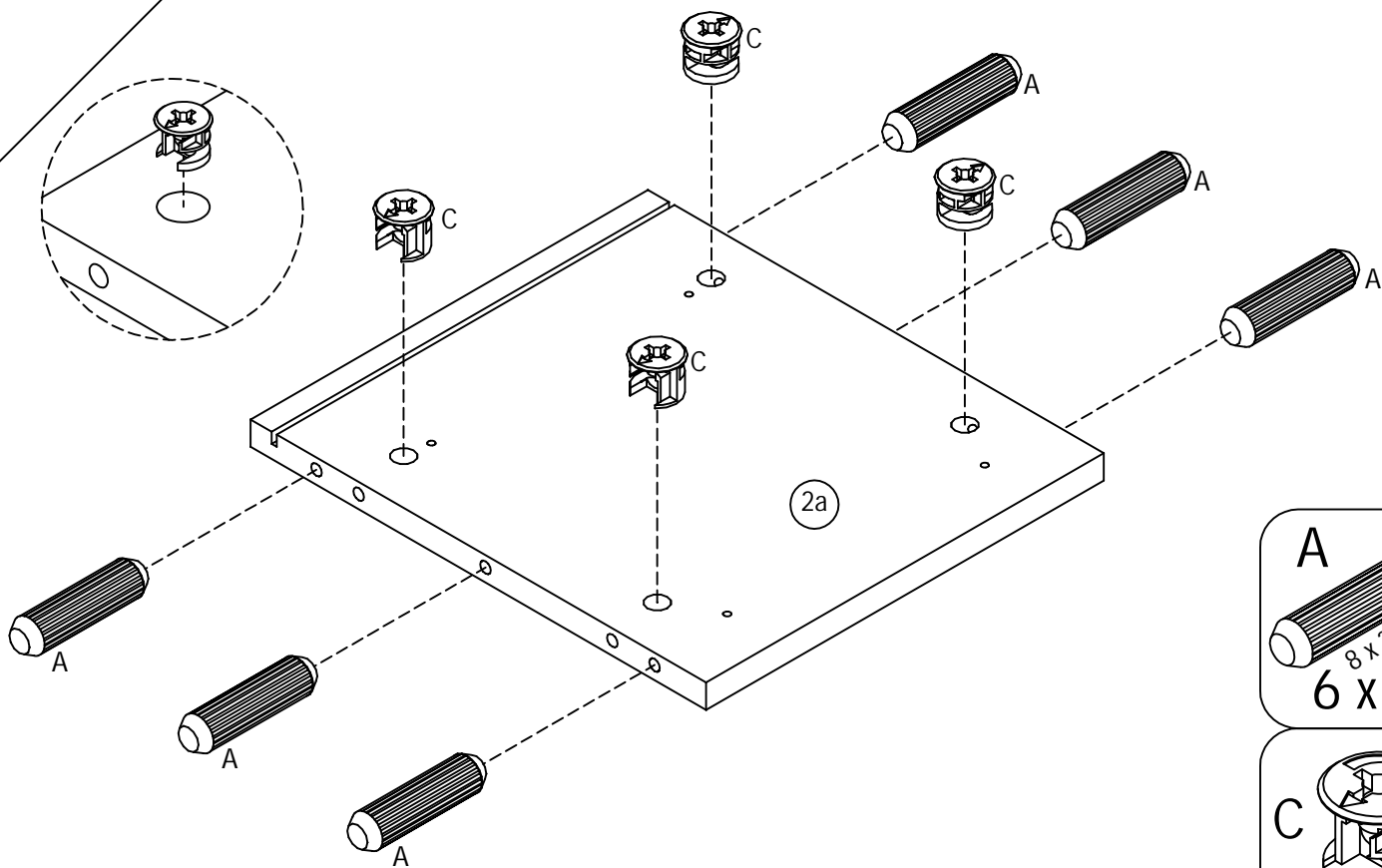

6

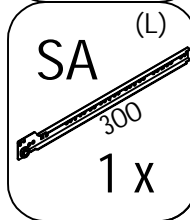
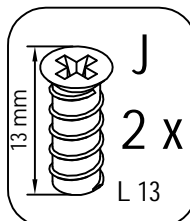
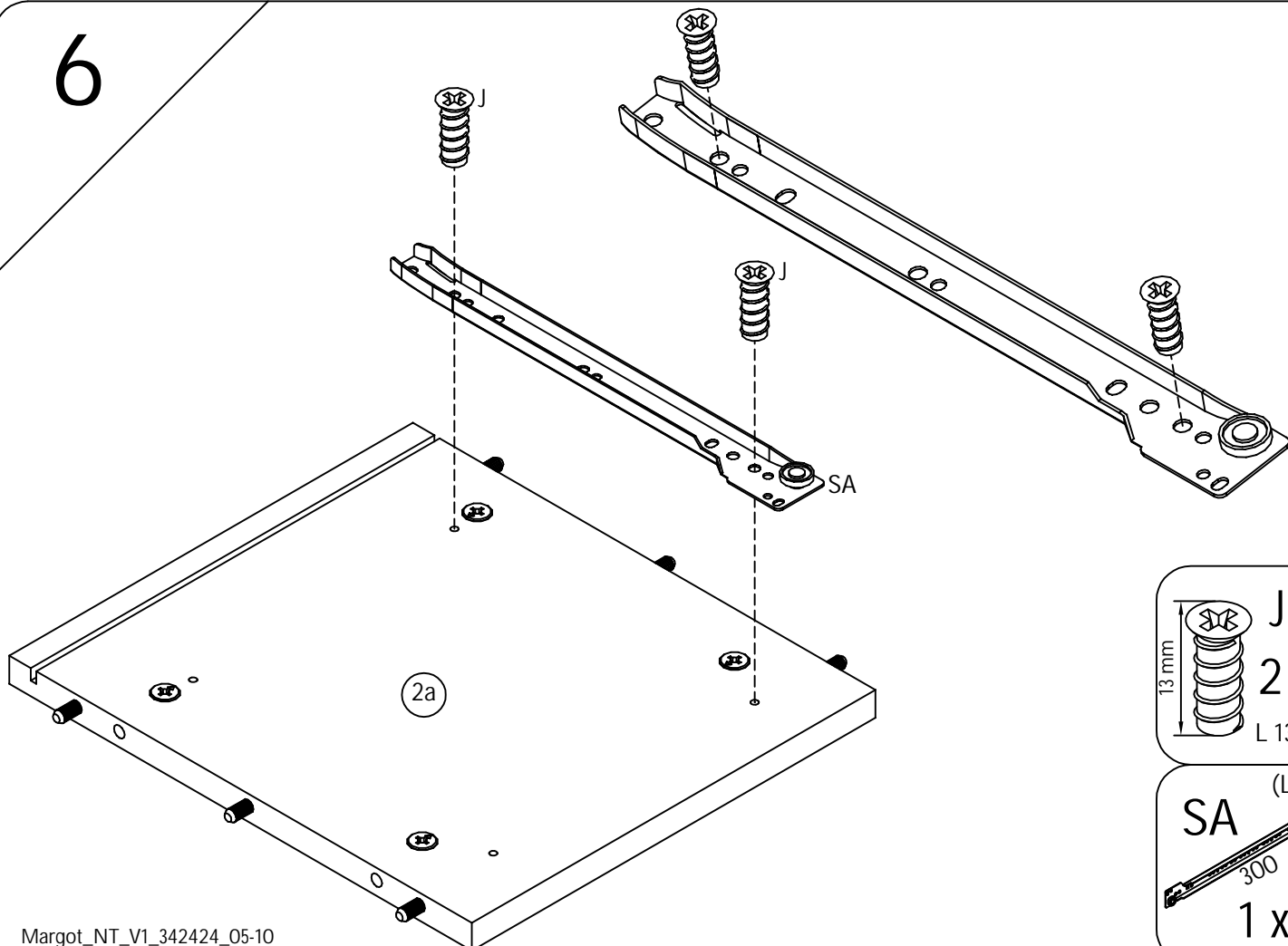

7

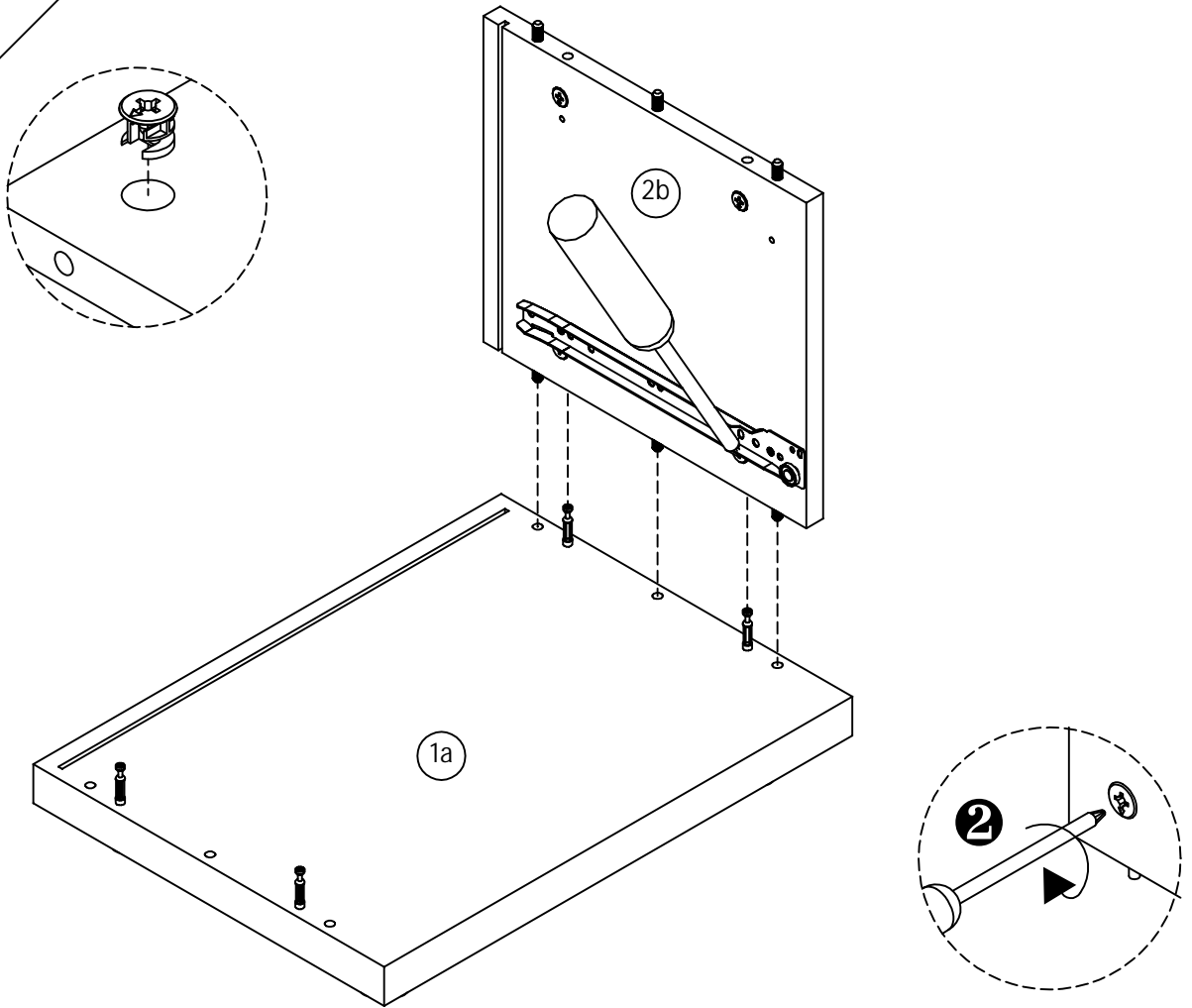

8

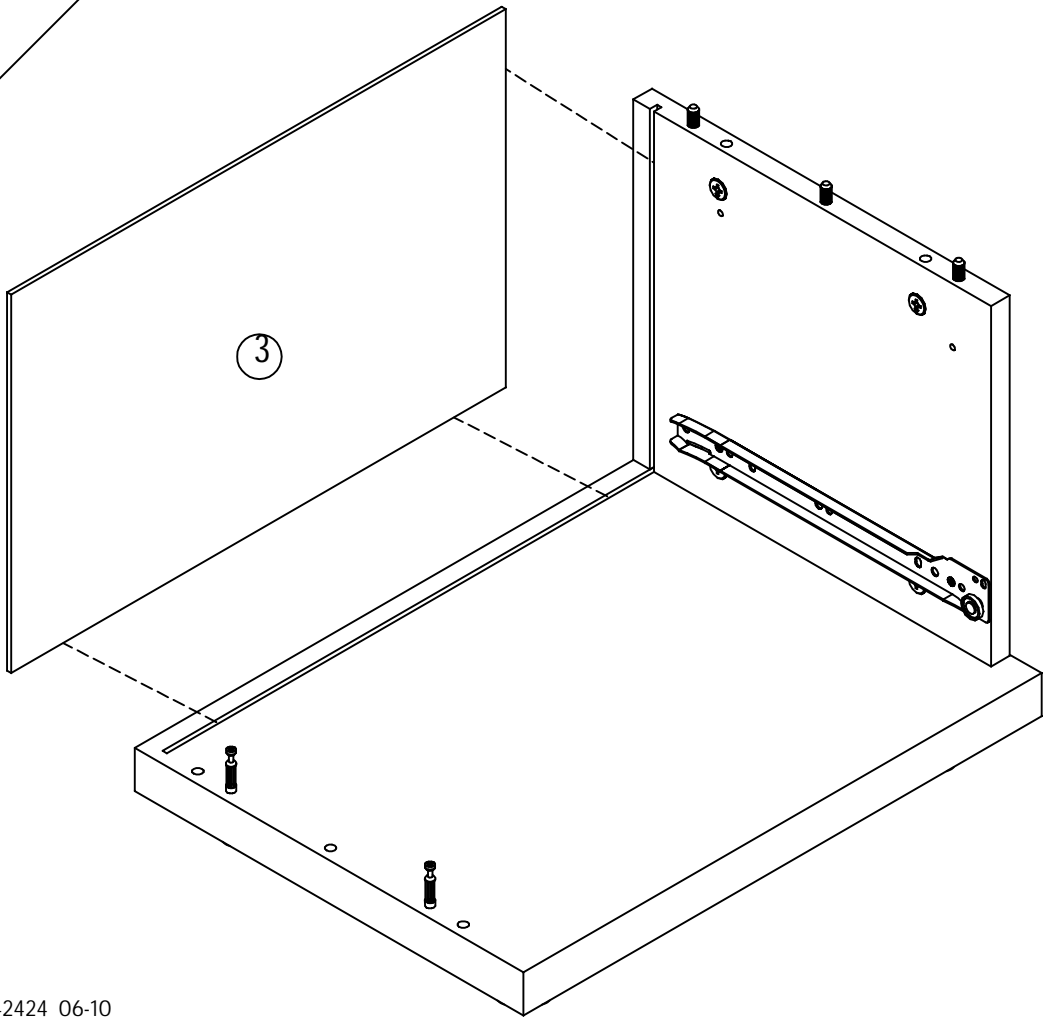

9

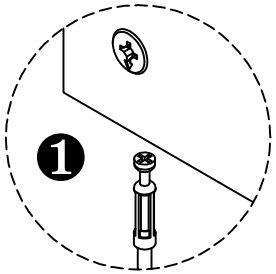
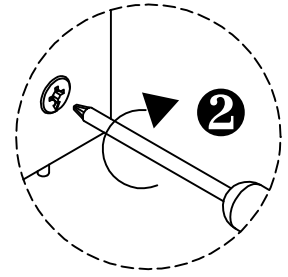
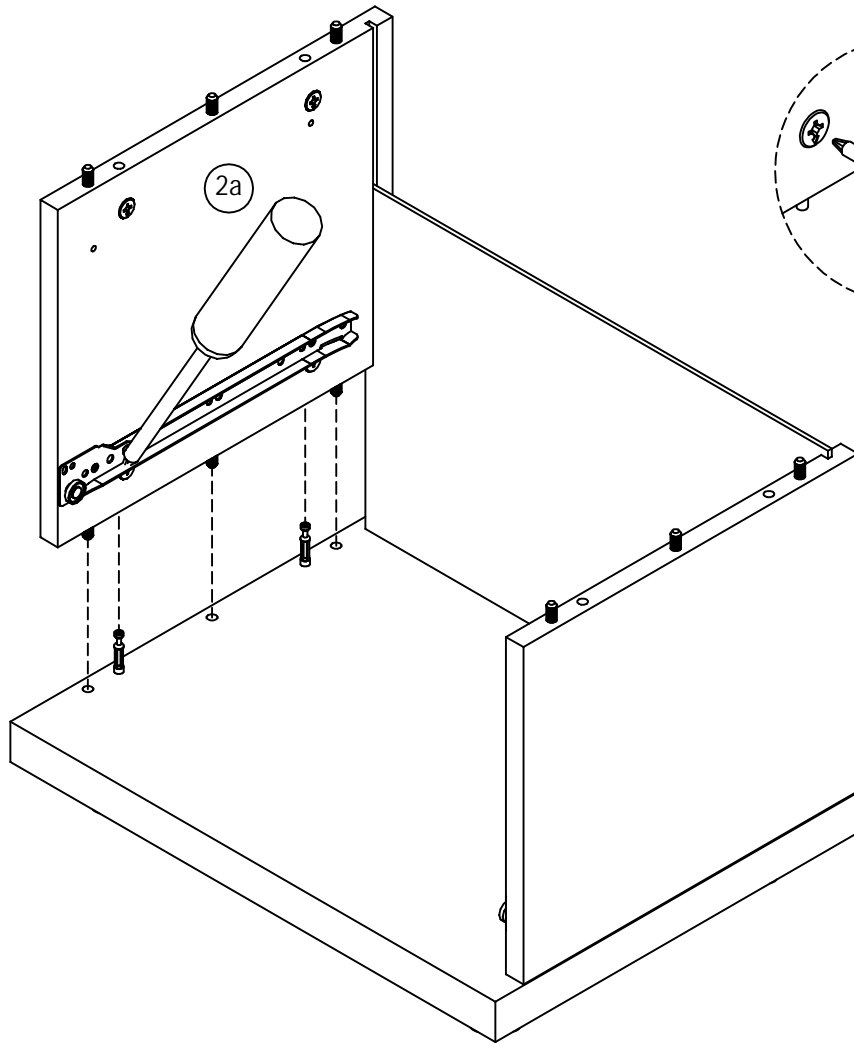

10

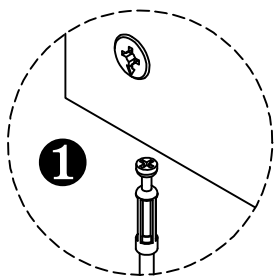
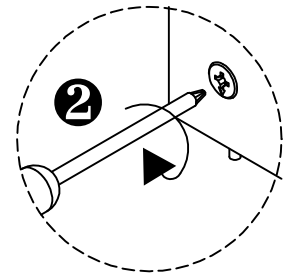
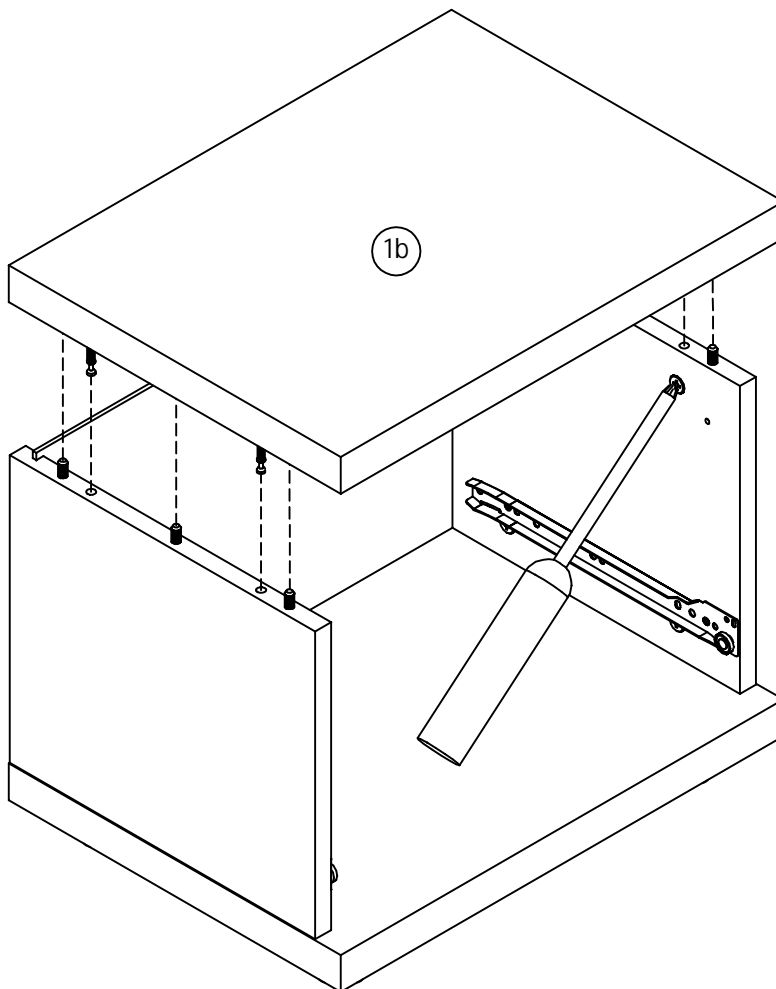

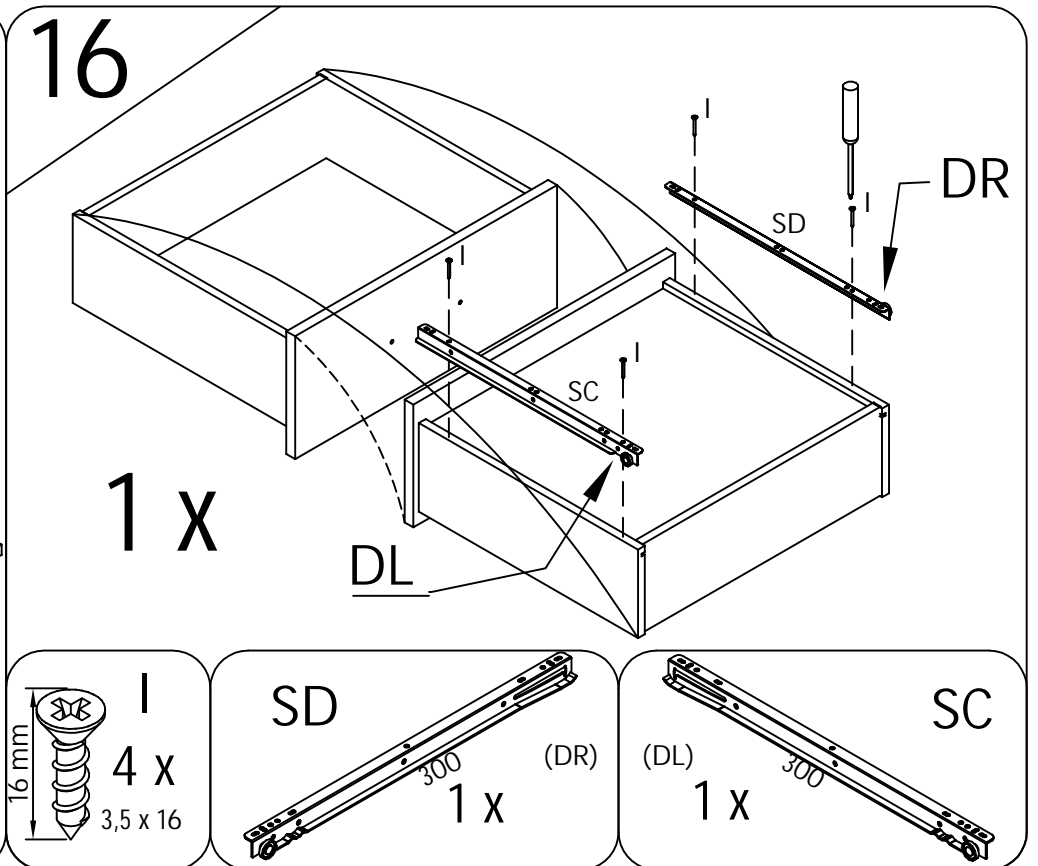
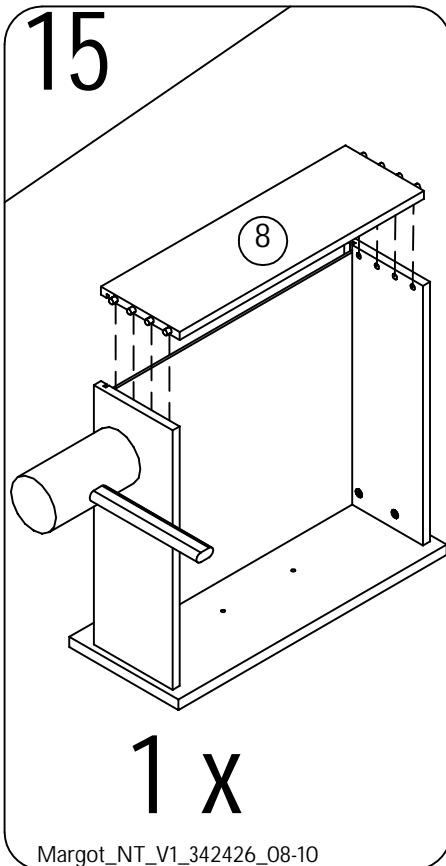
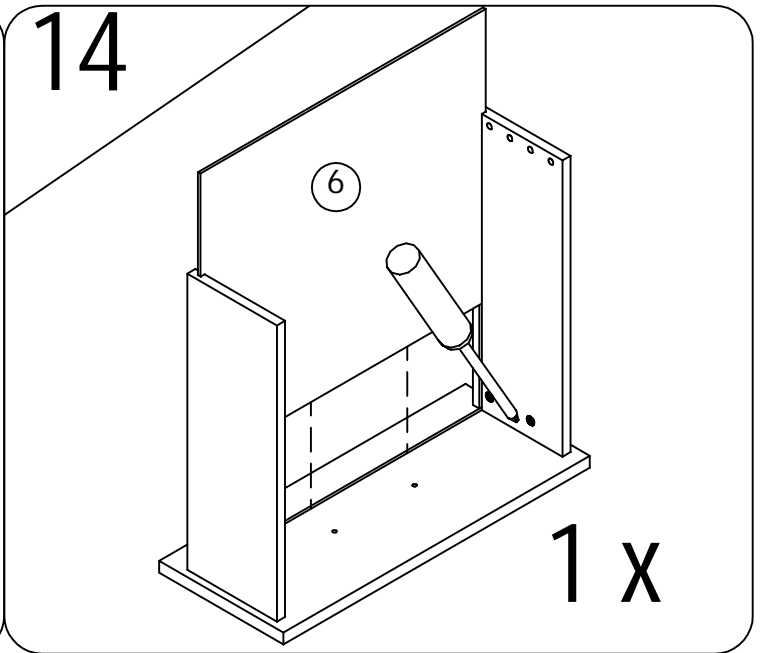
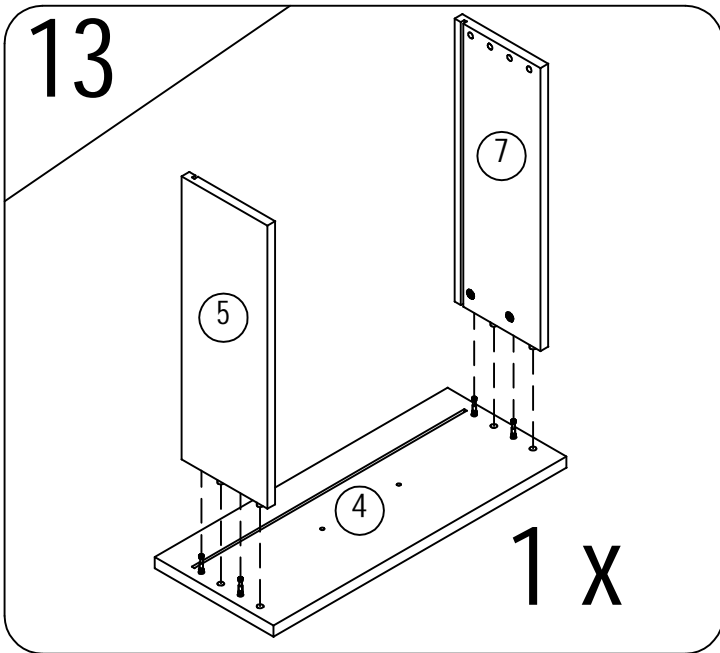
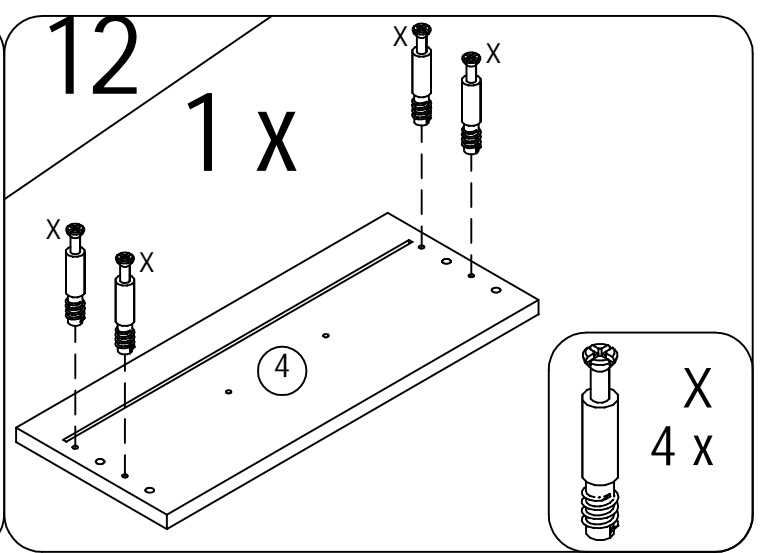
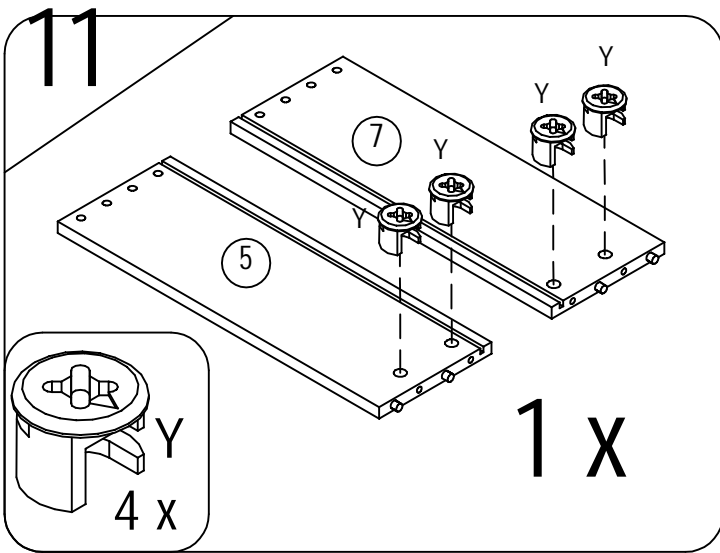



17

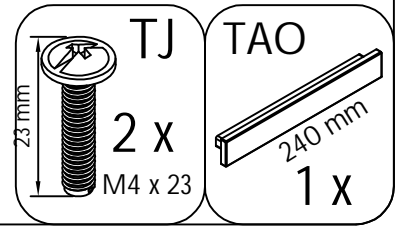
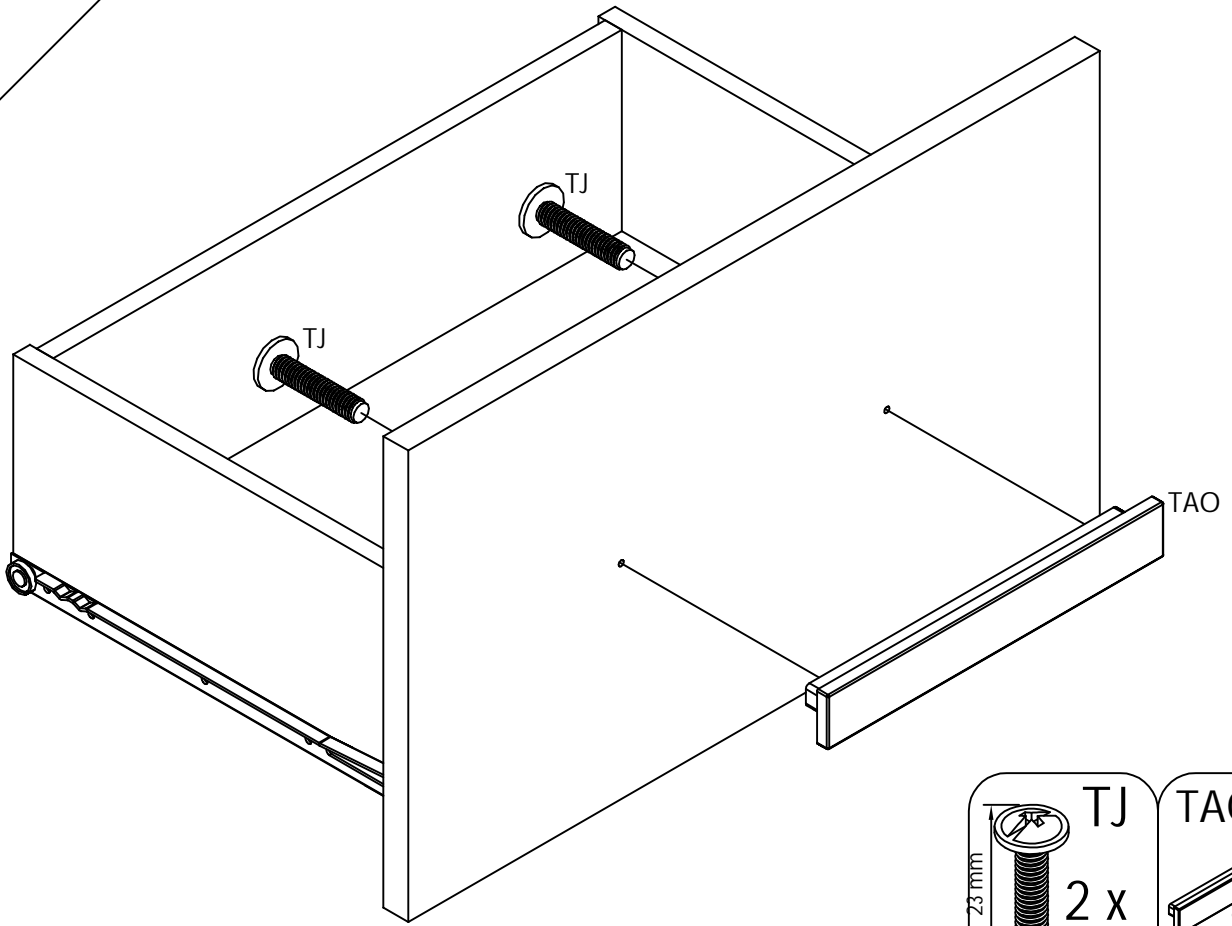

18

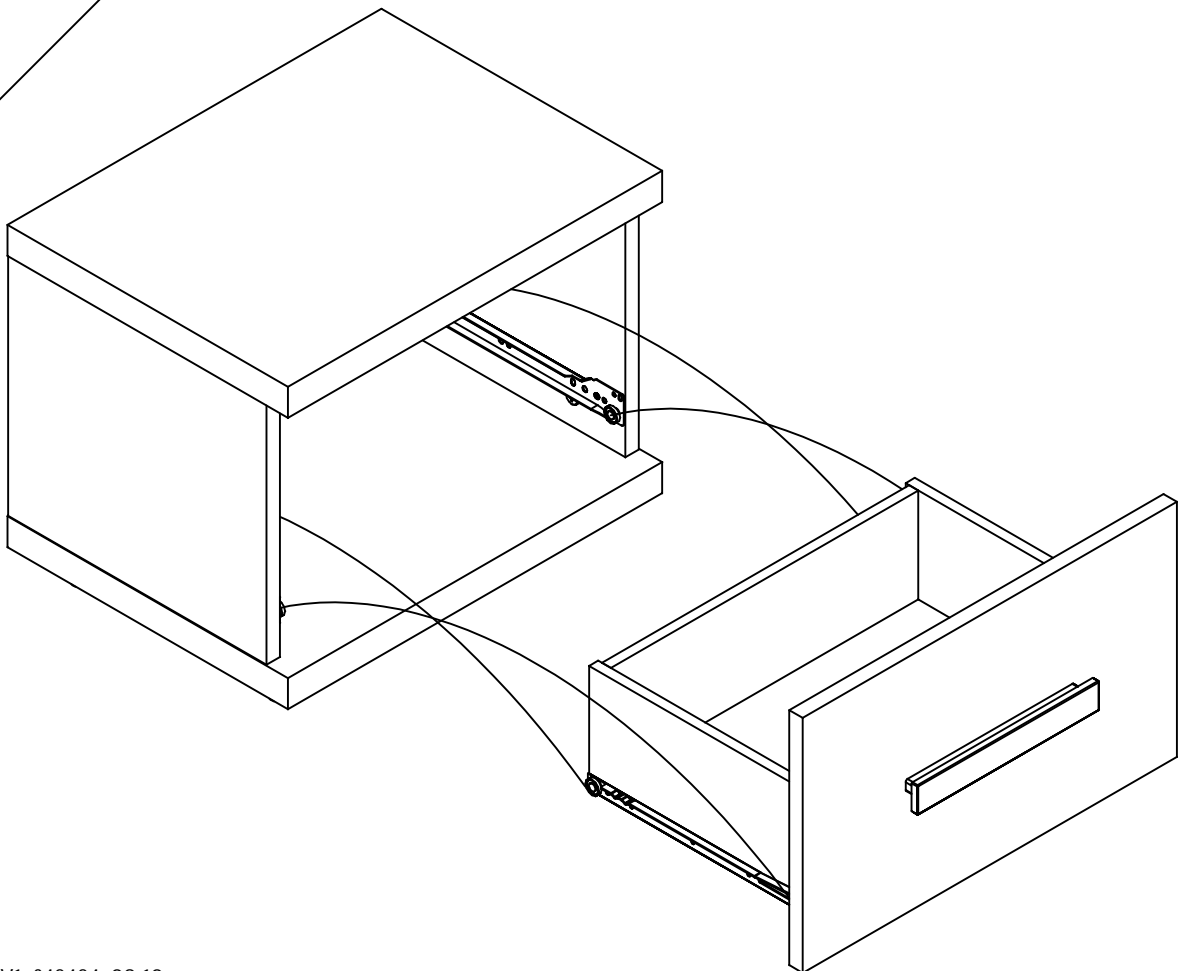

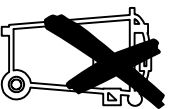
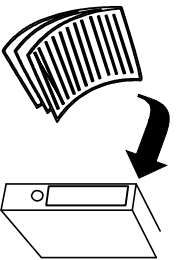
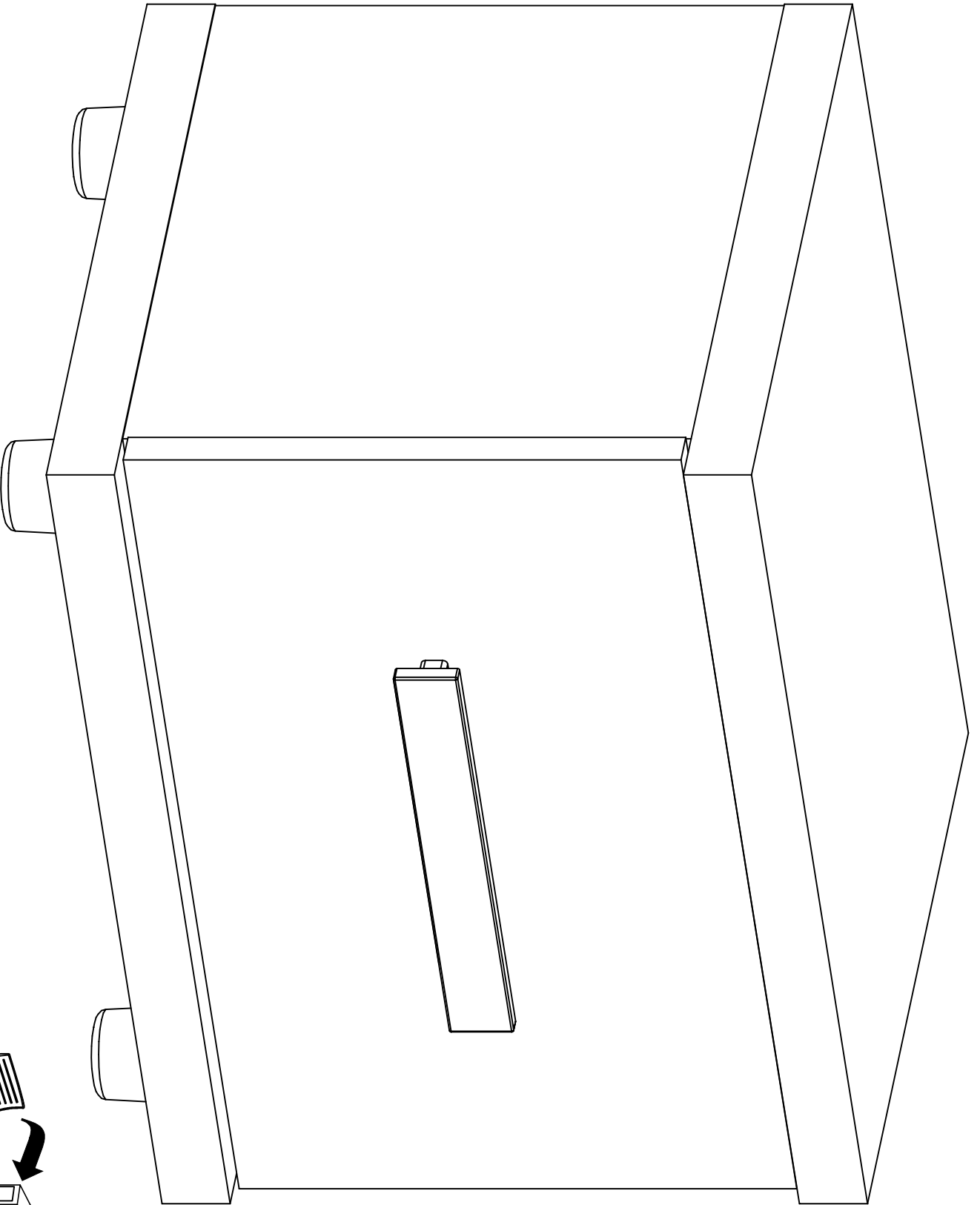

# Onderhoud - Entretien - Maintenance

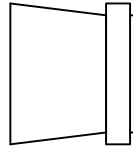

**NL**  
Oplosmiddel  
Reinigingsmiddel  
Verdunner  
Chemische Producten  
Boenwas

**FR**  
Solvant  
Detergent  
Diluant  
Produits chimiques  
Cirage

**GB**  
Solvent  
Cleaner  
Thinner  
Chemical Products  
Wax

**NL**

**Algemene Informatie :** Voor tafels geldt geen hete pannen, theeglazen en waxinelichtjes op de ondergrond plaatsen. Gebruik hiervoor altijd een onderzetter. Het meubel leegmaken en niet verslepen op de vloer bij eventuele verplaatsing.

**Onderhoud:** Met licht vochtige doek reinigen hierna direct droog wrijven. Vocht op het bovenblad direct opnemen. De meubels zijn niet voor vochtige ruimten bestemd. Gebruik nooit een schuurpons, schuurmiddel, amoniak, oplosmiddel, reinigingsmiddel, verdunner, chemische producten, boenwas of producten als Pledge was of dergelijke. Montage tekening opbergen.

**Service na verkoop:** Voor Service na verkoop, ga naar uw leverancier met deze montage handleiding.

**Garantie:** Het niet naleven van deze onderhoudsvoorschriften doet de garantie met onmiddellijke ingang verloren gaan.

**FR**

**L'information générale:** Ne mettez jamais des casseroles chaudes, des verres à thé sur la surface des tables. Veuillez utiliser des sous verres. Videz le meuble avant tout déplacement/ Portez le meuble et non pas le pousser sur le sol !

**Entretien:** utilisez un chiffon légèrement humide et sèche aussitôt. Toute trace de liquide doit être enlevé immédiatement. Les meubles ne sont pas adaptés aux pièces humides. N'utilisez jamais des éponges abrasives, amoniak, solvant, détergent, diluant, produits chimiques ou cirage ou des produits d'entretien comme Pledge etc... . Notice de montage à conserver.

**Service après-vente :** Pour tout service après-vente, rendez vous au magasin avec cette notice.

**Garantie:** Nous vous informons qu'en cas de non respect aux prescriptions sus - mentionnés que la garantie expire immédiatement.

**GB**

**General information :** Do never put hot items on the table tops ! Empty furniture before moving and do not drag the furniture over the floor.

**Maintenance :** Clean with slightly wet moistened cloth, wipe dry immediately. Wipe off wetness at once. Not suited for humid locations. Never use Solvent, cleaner, thinner, chemical products or wax. Retain manual instruction.

**For the after sales :** For the after sales, go back to the shop with this assembly instructions.

**Guarantee :** Attention in case of non respect to the above prescriptions the warranty expires immediately.

## **Dienst na verkoop**

Beste klant,

Wij danken u voor de aankoop van dit meubel.

Ondanks de zorg die wij besteden aan de productie en verpakking van onze meubelen, kan het voorkomen dat er iets ontbreekt of beschadigd is.

Is dit het geval vragen wij u om via bijgaand formulier uw DNV te melden aan de winkel waar u uw meubel heeft aangekocht.

Bij schade vragen wij u ook om volgende:

- 1) een foto van het complete meubel(onderdeel)
- 2) een detailfoto van het probleem

Op die manier kunnen wij u zo vlug mogelijk helpen om uw probleem op te lossen.

Met vriendelijke groet,

---

## **Service après vente**

Cher client,

Nous vous remercions pour l'achat de ce meuble.

Malgré tout les soins que nous consacrons à la production et le conditionnement de nos meubles, il est possible que quelque chose est manquant ou endommagé.

Si c'est le cas, nous vous demandons d'utiliser le formulaire ci-joint pour déclarer votre plainte au magasin où vous avez acheté vos meubles.

En cas de dommages, nous vous demandons également de prendre les photos suivants et de nous les envoyer:

- 1) une photo du mobilier complet (partie)
- 2) une photo de détail du problème

De cette façon, nous pouvons vous aider le plus vite possible afin de résoudre votre problème.

Sincèrement,

## **FORMULIER DNV - FORMULAIRE SAV**

**Terug te sturen naar uw winkel**

**A renvoyer à votre magasin**

<b>DATUM./DATE :</b>	
<b>UW GEGEVENS / VOS DONNEES</b>	
<b>NAAM/NOM :</b>	
<b>ADRES/ADRESSE :</b>	
<b>E-MAIL:</b>	<b>TEL./GSM</b>

<b>GEGEVENS OVER HET PROBLEEM - DONNEES SUR LE PROBLEME</b>	
<b>Datum aankoop / Date d'achat:</b>	
<b>Naam model en meubelonderdeel Nom modèle et partie du meuble</b>	
<b>Onderdeelnr. of colli nr. (zie het montageplan) N° de pièce ou coli (voir le plan de montage)</b>	
<b>Kleur of stof Couleur ou tissu</b>	
<b>Digitale foto's in bijlage Photos digitales en annexe</b>	<b>JA/OUI <input type="checkbox"/> - NEE/NON <input type="checkbox"/></b>

<b><u>Gedetailleerde omschrijving van het probleem :</u></b> <b><u>Description détaillée du problème:</u></b>
--