

SANDRA II COMMODE

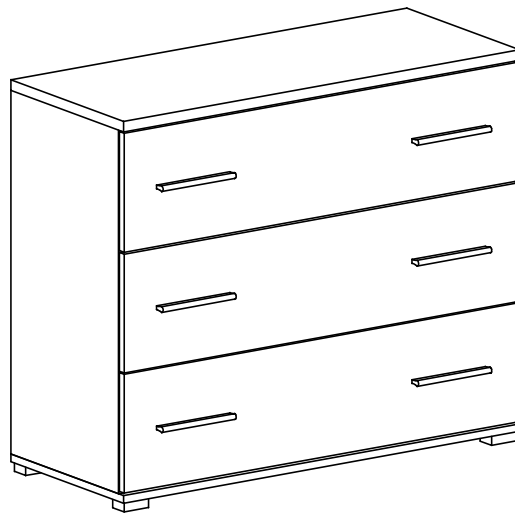

(D) Montageanleitung

(NL) Handleiding voor de montage

(TR) Montaj talimatı

(F) Notice de montage

(CZ) Montážní návod

(HU) Szerelési útmutató

(GB) Assembly instructions

(PL) Instrukcja montażu

(RU) Инструкция по монтажу

(IT) Istruzioni di montaggio

(SK) Návod na montáž

(RO) Instrucțiuni de montaj

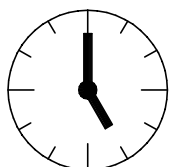
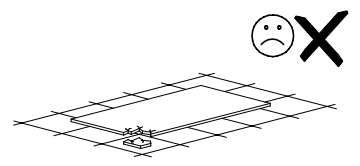
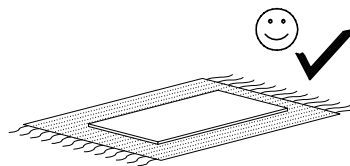
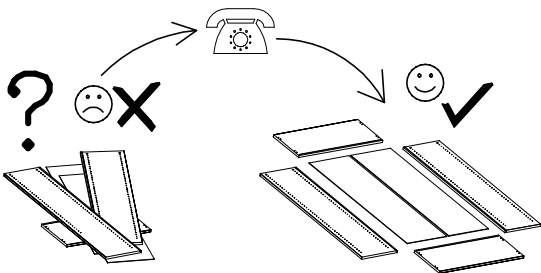
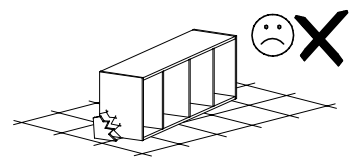
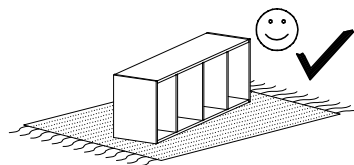
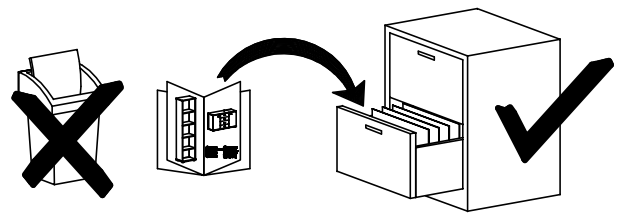
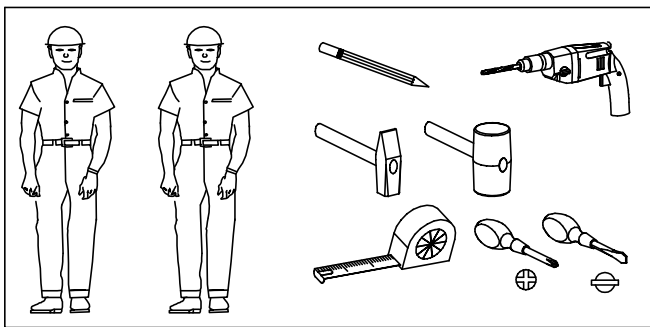

1,5h

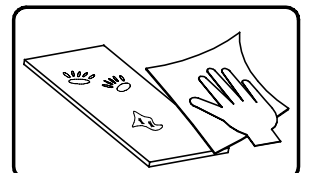
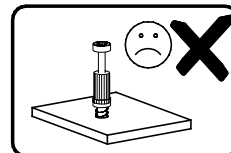
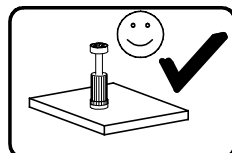

Name • Nom • Nome • Naam • Nazwa • Jméno
• Názov • Név • Denumire • Isim • Название

Nr • No • N° • Номер • Č • Sz

Typ • Type • Tip • Típus • Tipo • Tun

SANDRA II

COMMODE

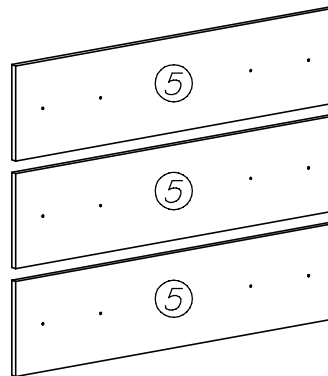
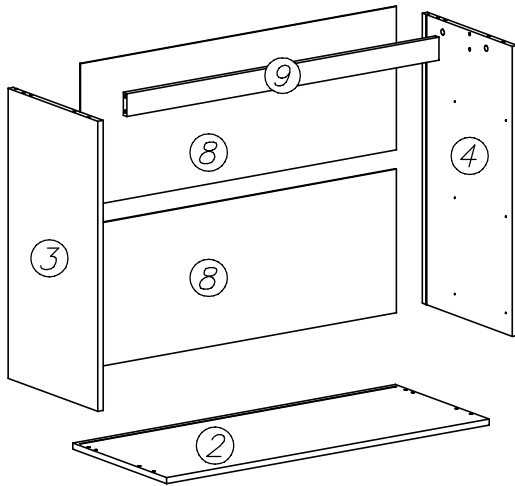
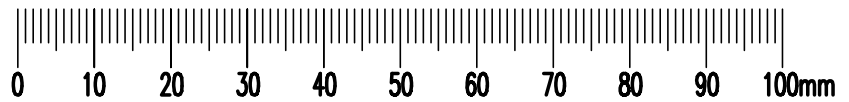
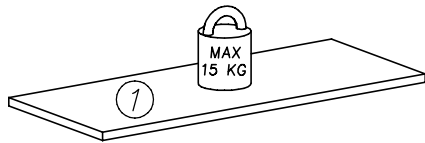
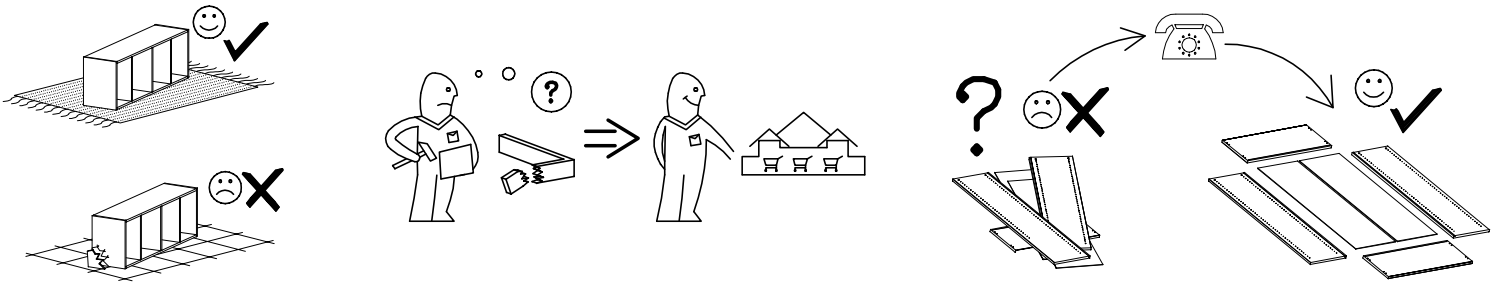

nr	L[mm]	B[mm]	T[mm]	Menge	Colli
1	975	396	22	1	1/1
2	975	396	16	1	1/1
3	759	378	16	1	1/1
4	759	378	16	1	1/1
5	969	248	16	3	1/1
6	892	140	12	3	1/1
7	902	301	3	3	1/1
8	954	385	3	2	1/1
9	942	60	16	1	1/1
10	300	100	12	3	1/1
11	300	100	12	3	1/1

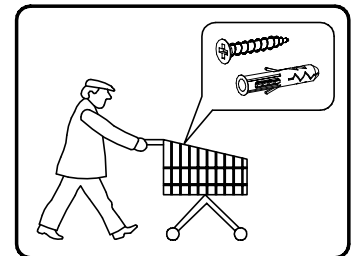
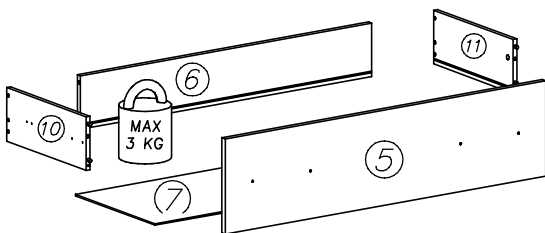

M11 x...(1)	S1 941mm x...(1)	E24 160mm x...(6)	K4 ø12x10 x...(6)		
G8 4x30 x...(12)	G12 4x25 x...(8)	P15 x...(4)	M8 300mm x...(3)	A6 ø7x40 x...(12)	
K10 x...(10)	G34 3,5x16 x...(8)	K1 ø15x12 x...(4)	B1 ø8x35 x...(14)	H23 H35-300mm x...(3)	G20 5x11 x...(24)
A1 ø7x50 x...(4)	I7 x...(4)	W2 x...(1)	I1 x...(8)	W1 GLUE LEM. LEPILO. LM x...(3)	



A

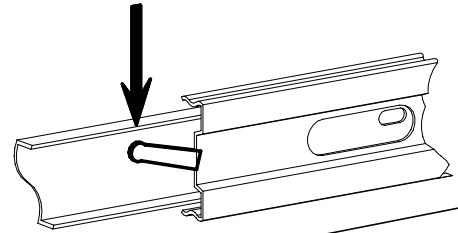
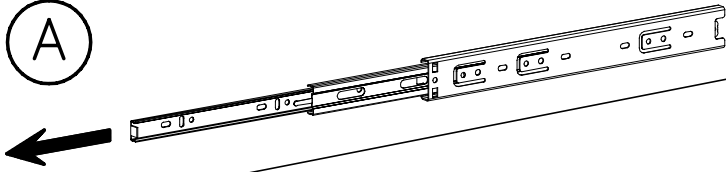

B

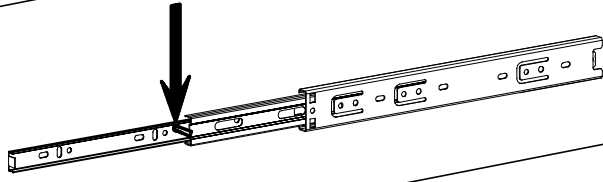

C

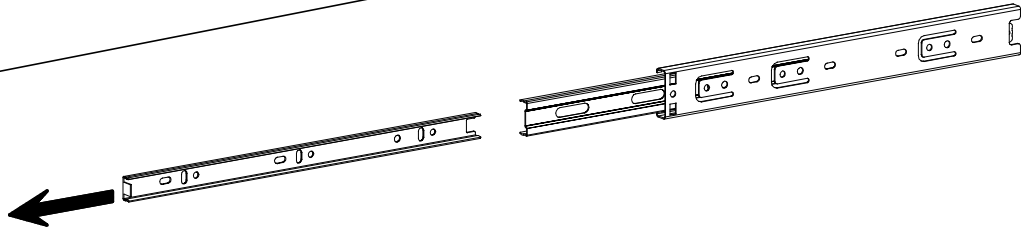

I G20

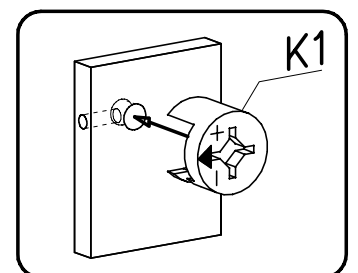
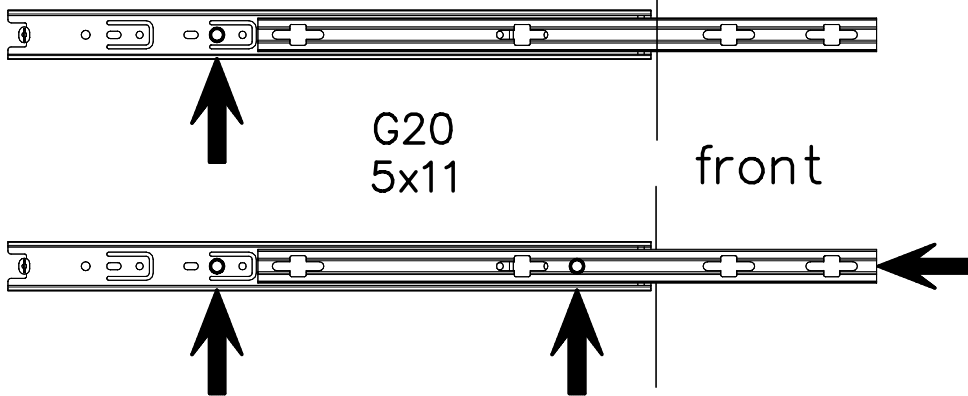
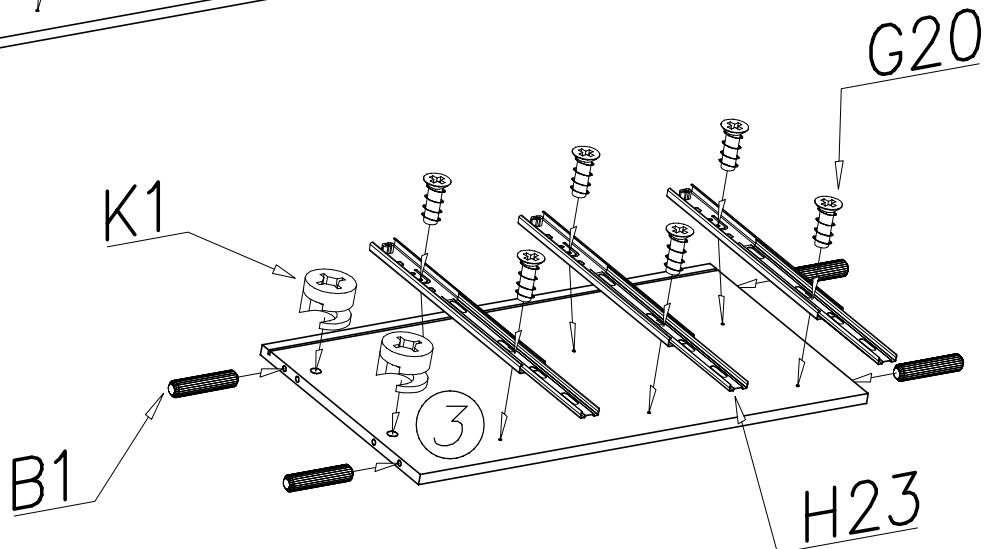
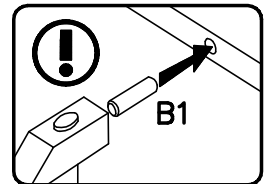
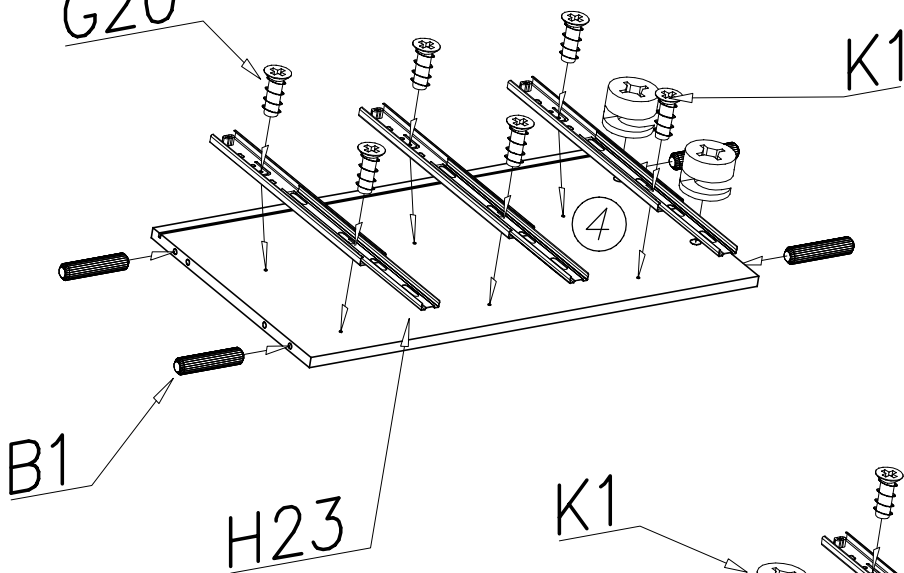

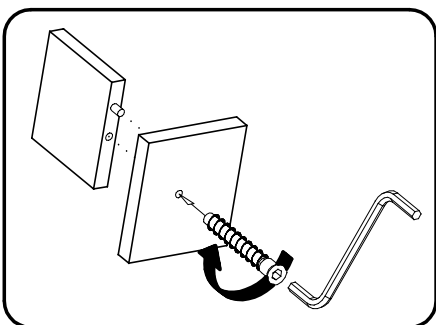
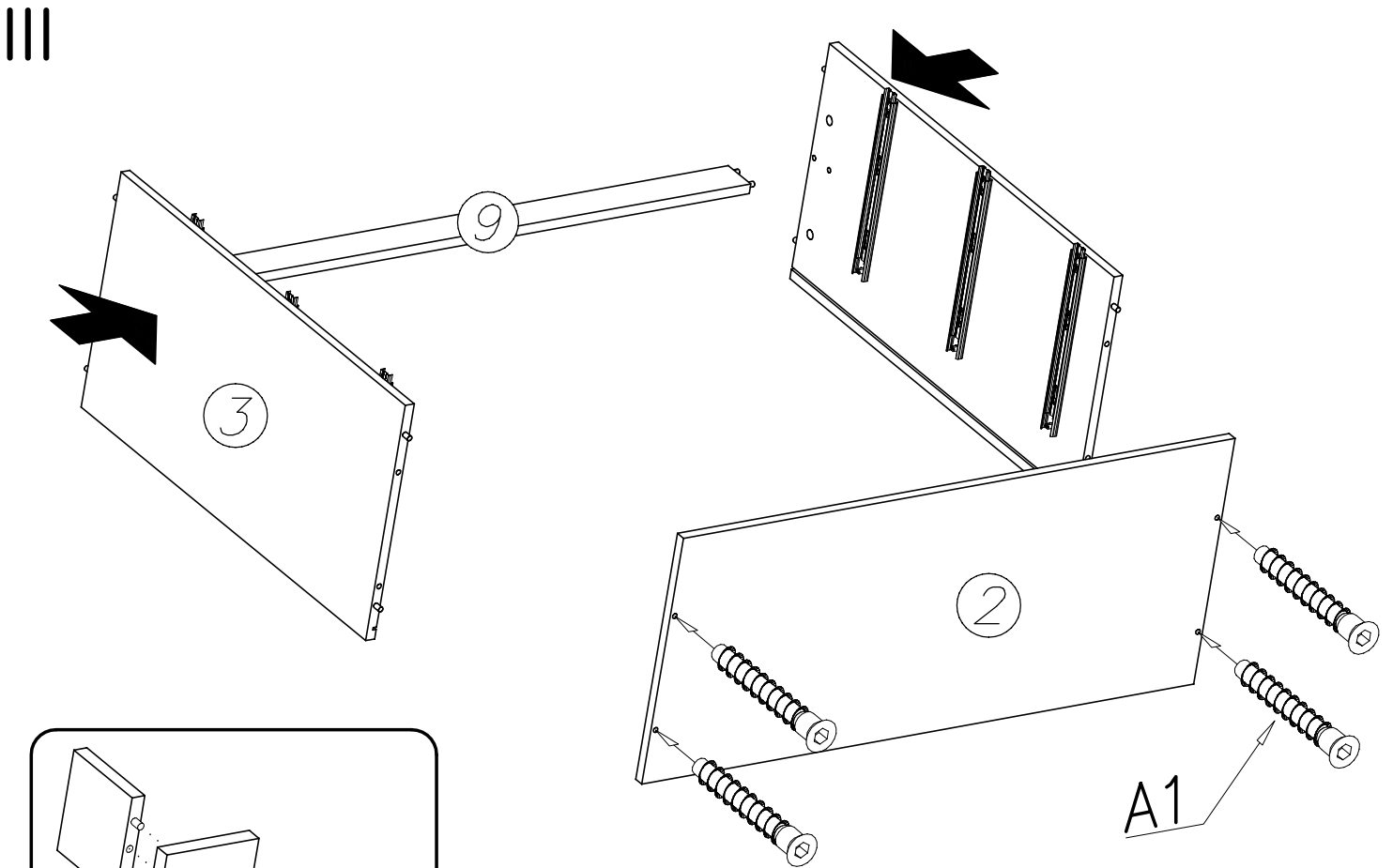
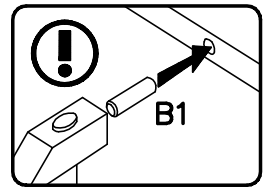
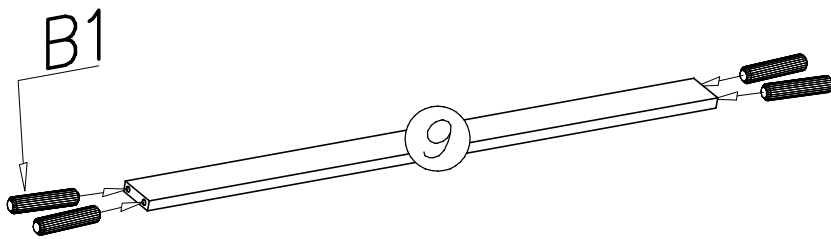
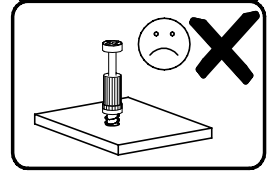
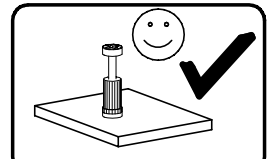
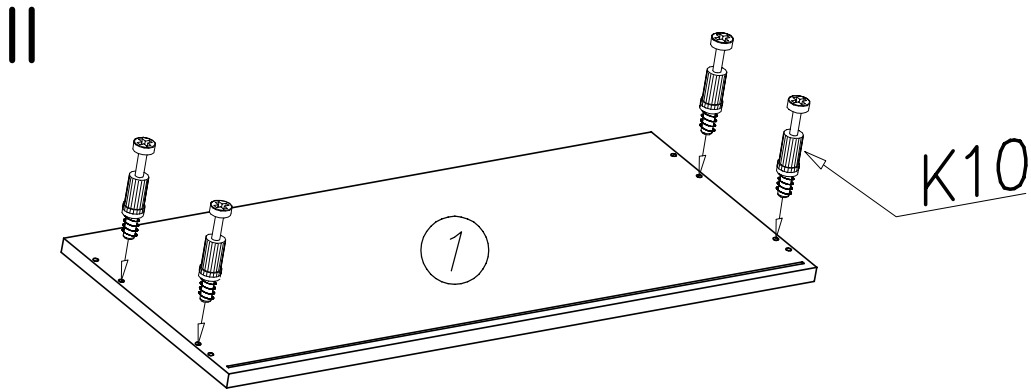



IV

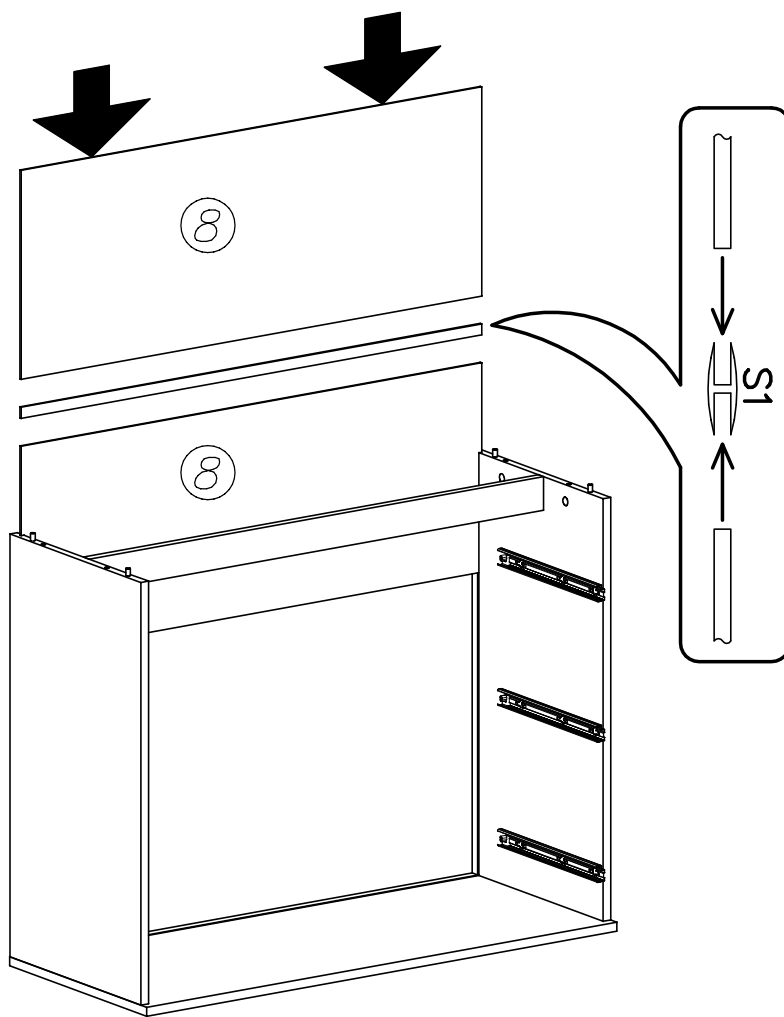

V

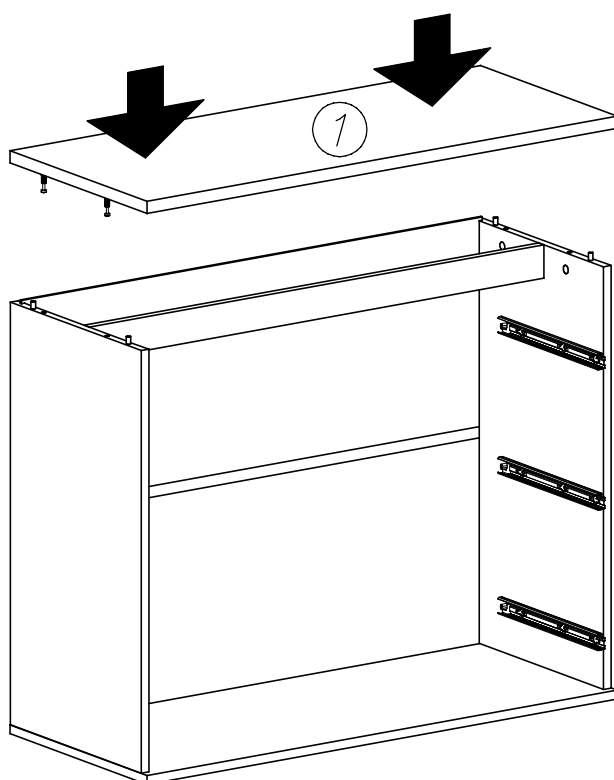
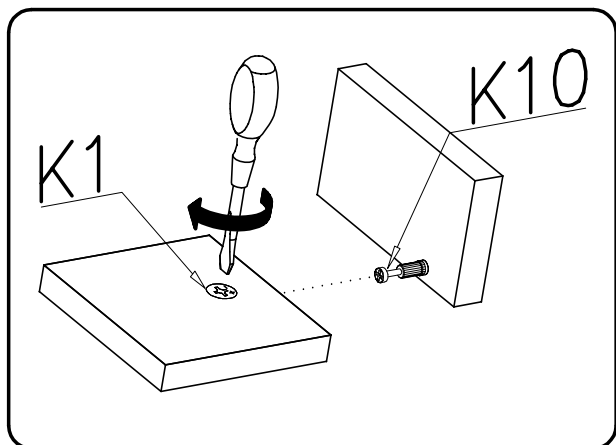



VI

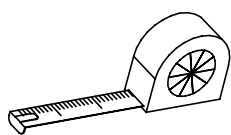

A=B

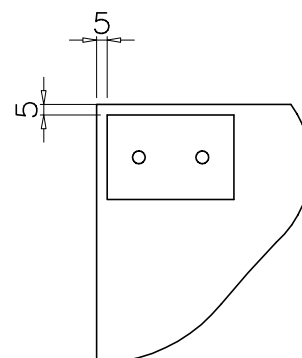
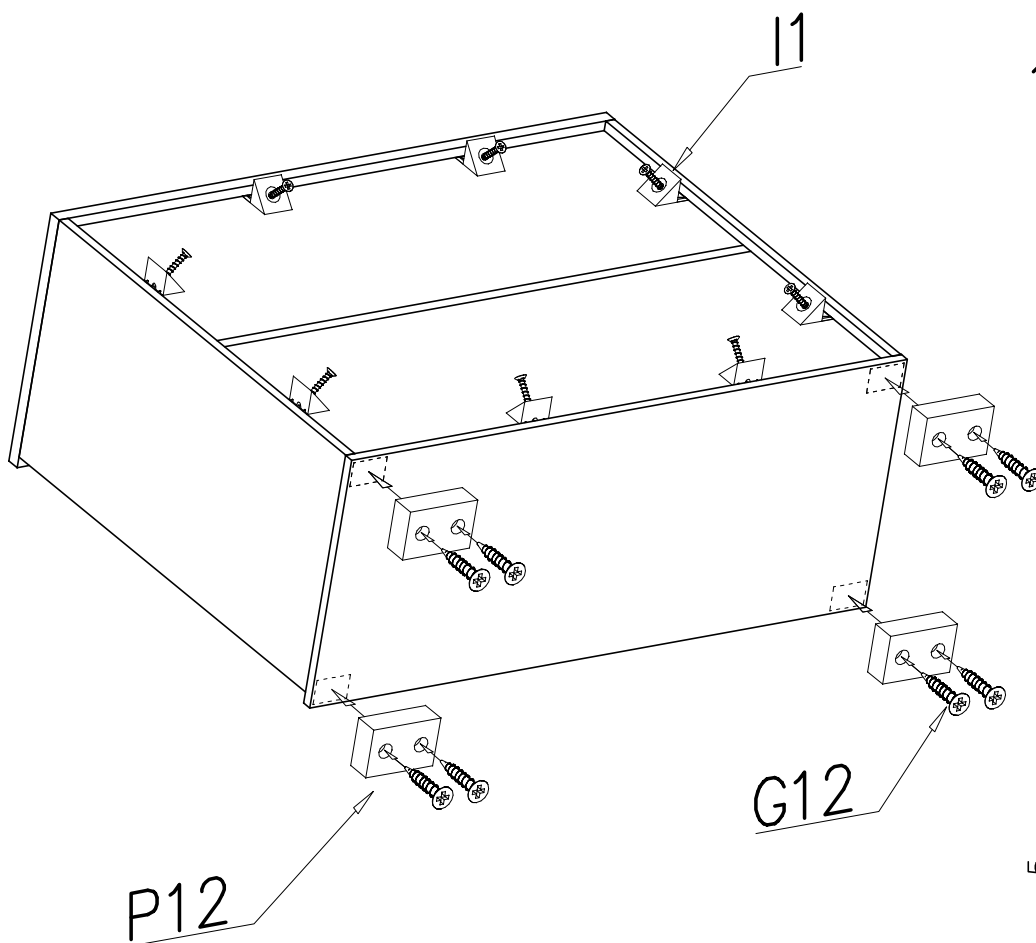
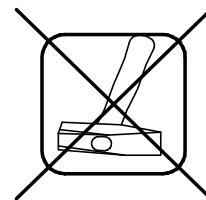
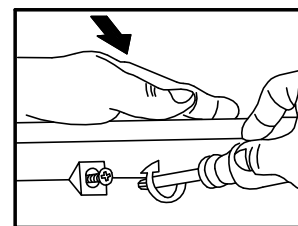
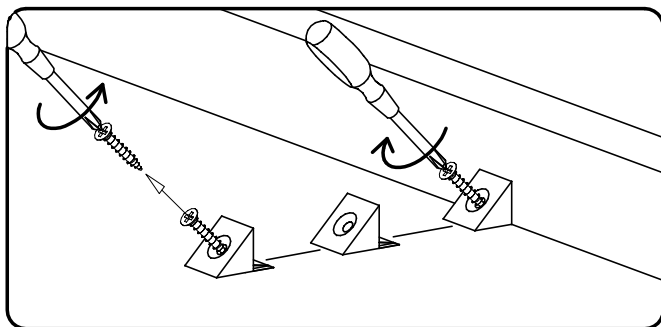
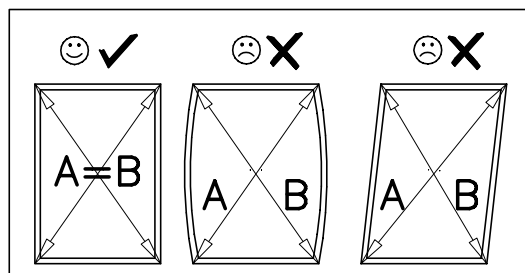



VII

3x

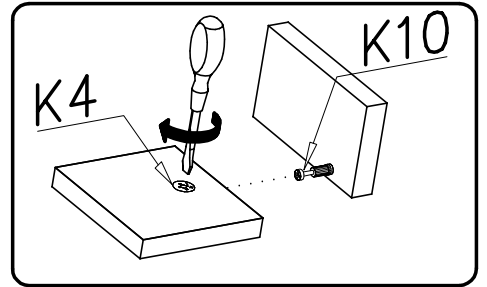
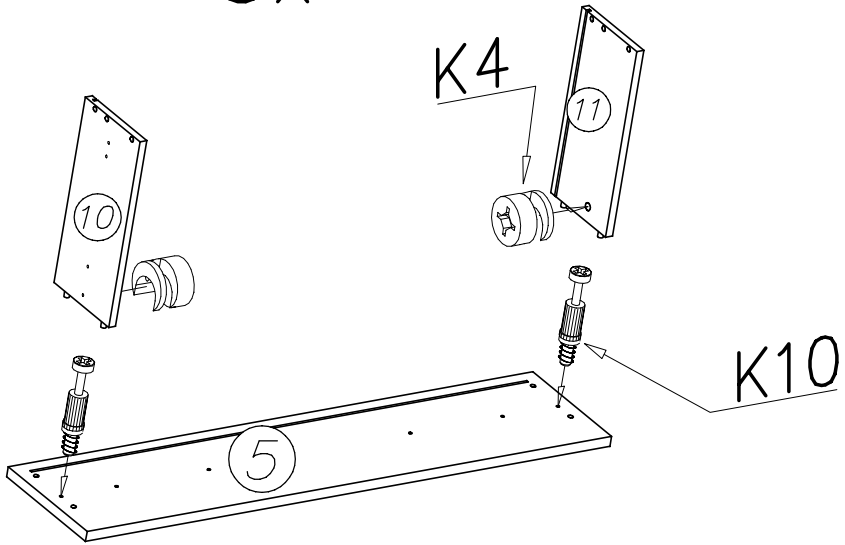

3x

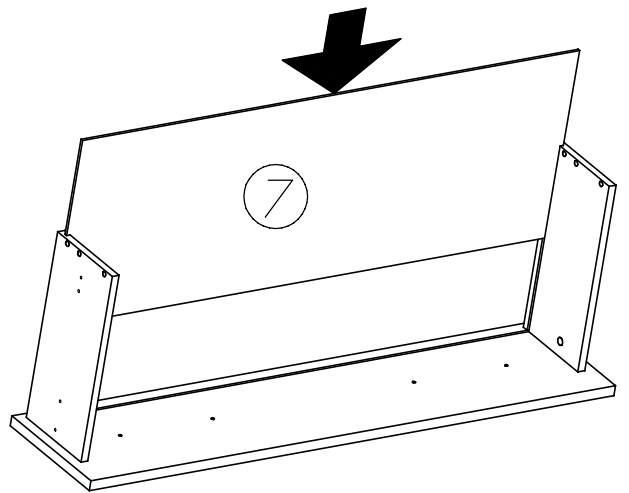

A6

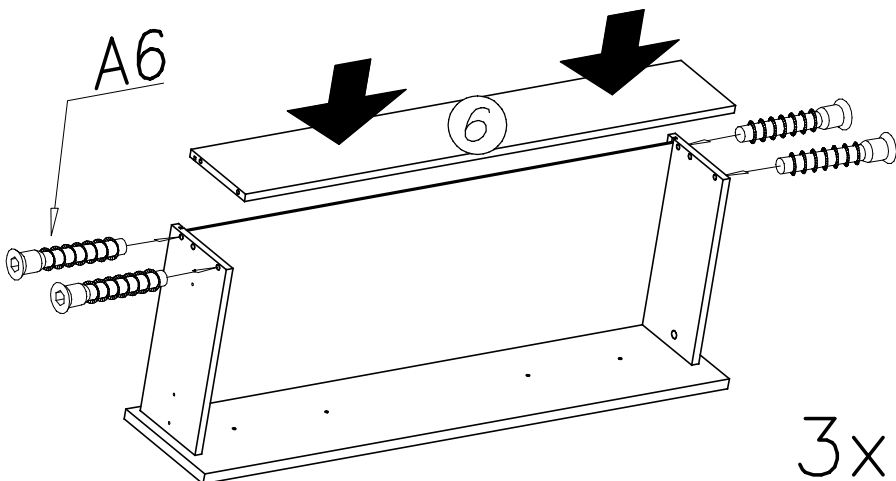

3x



VIII

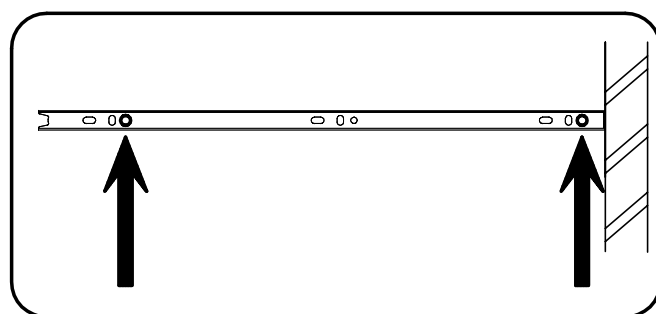
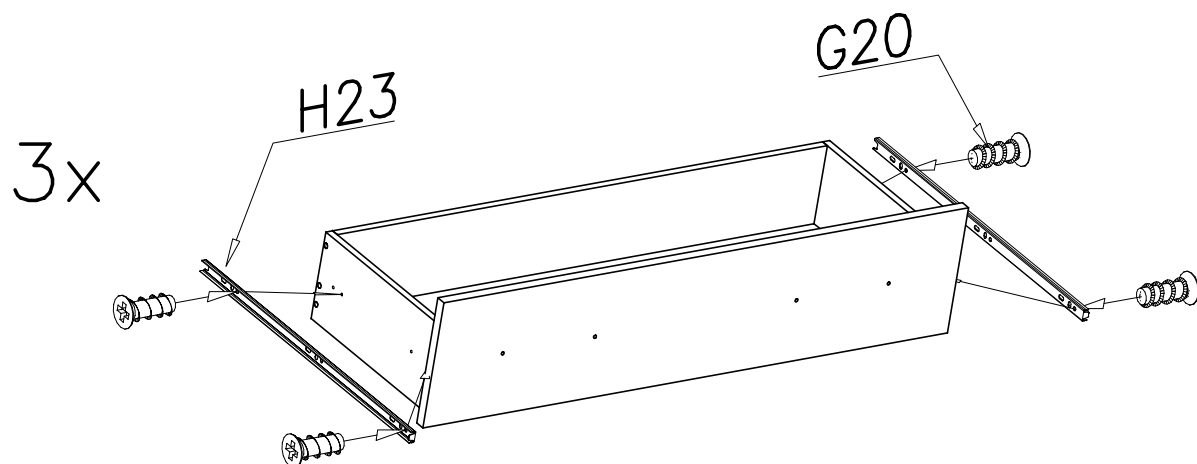

3x

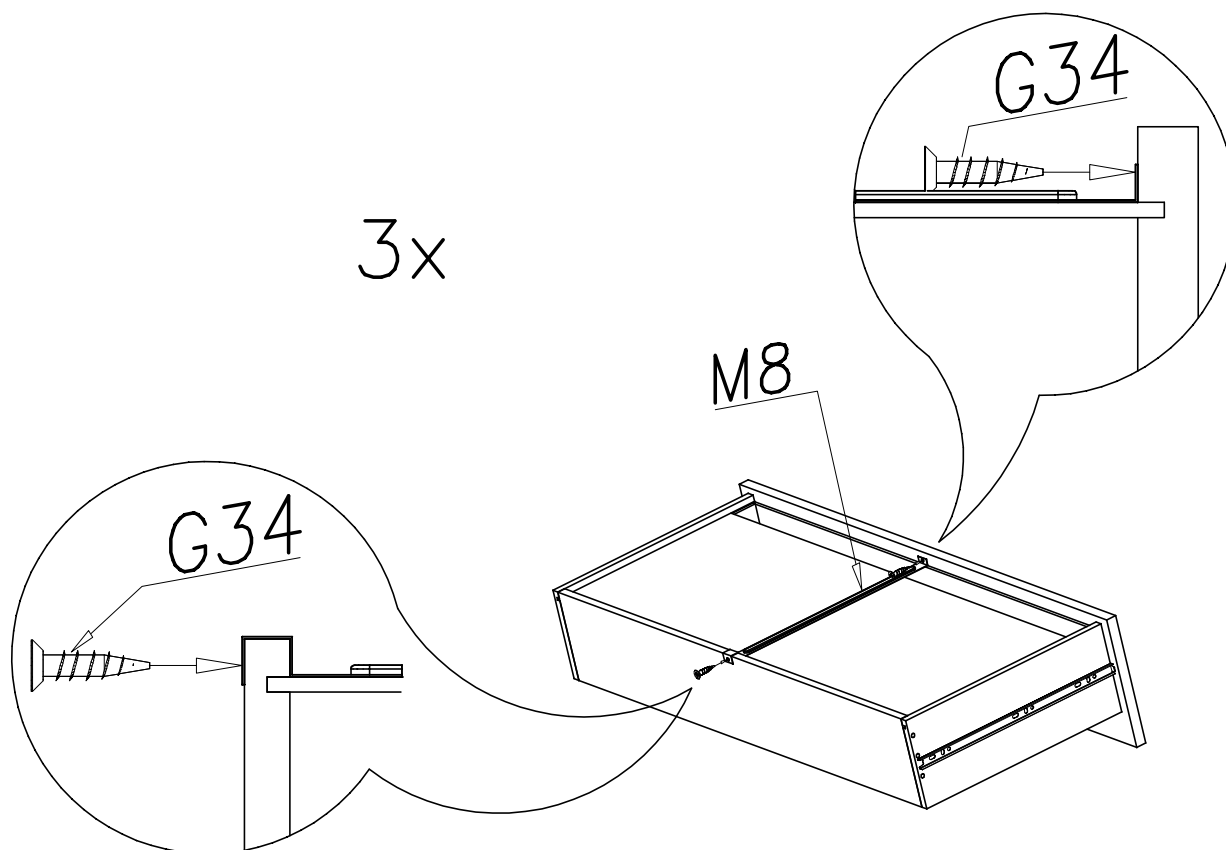



IX

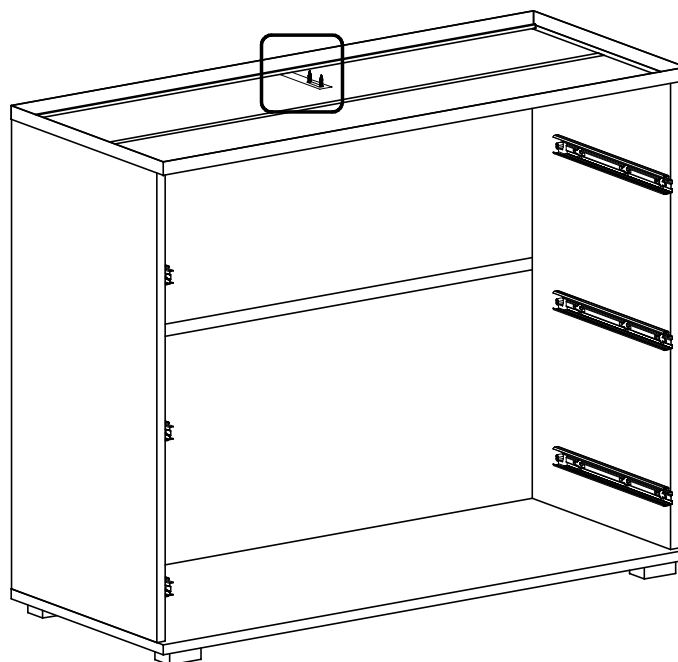
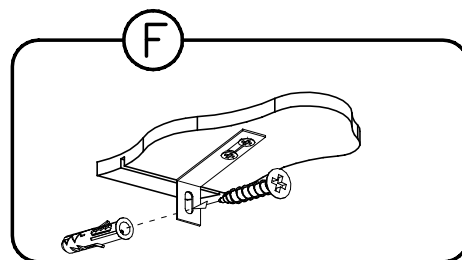
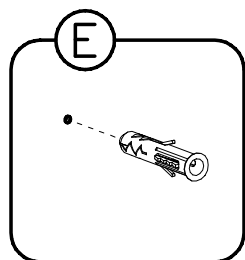
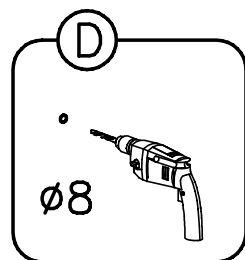
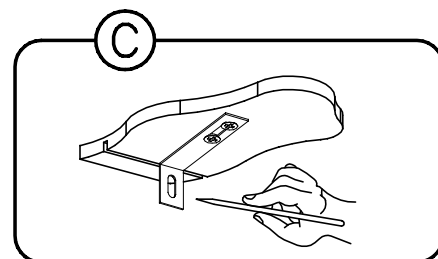
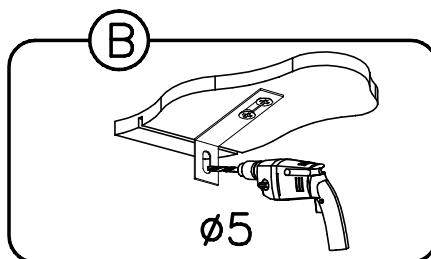
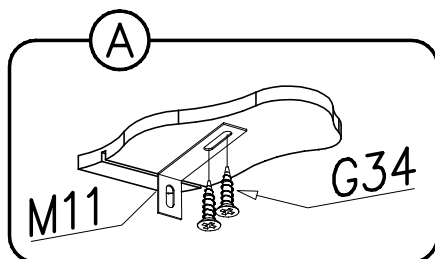
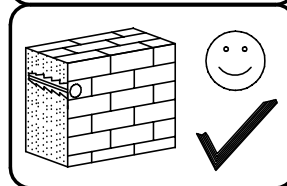
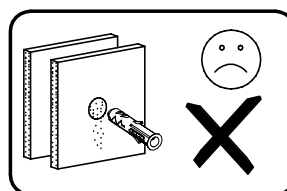
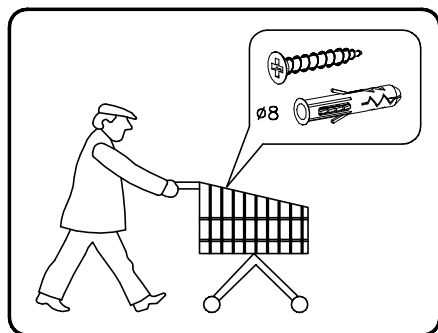



X

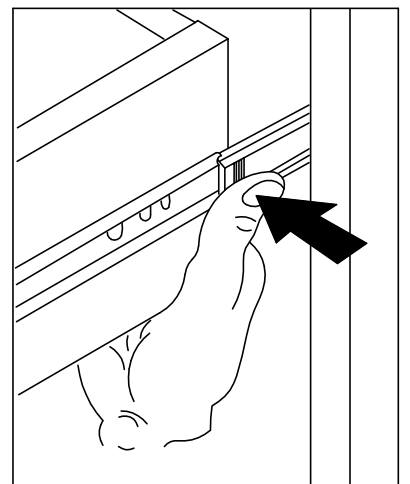
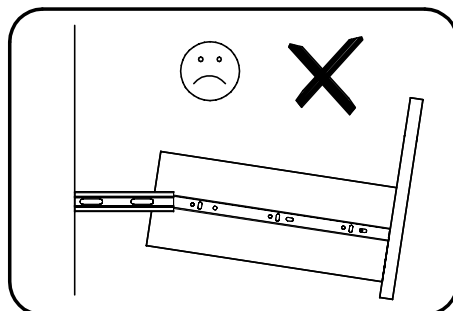
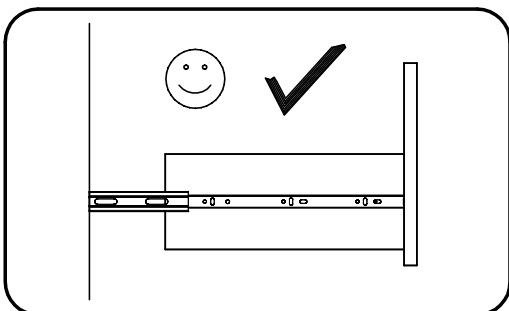
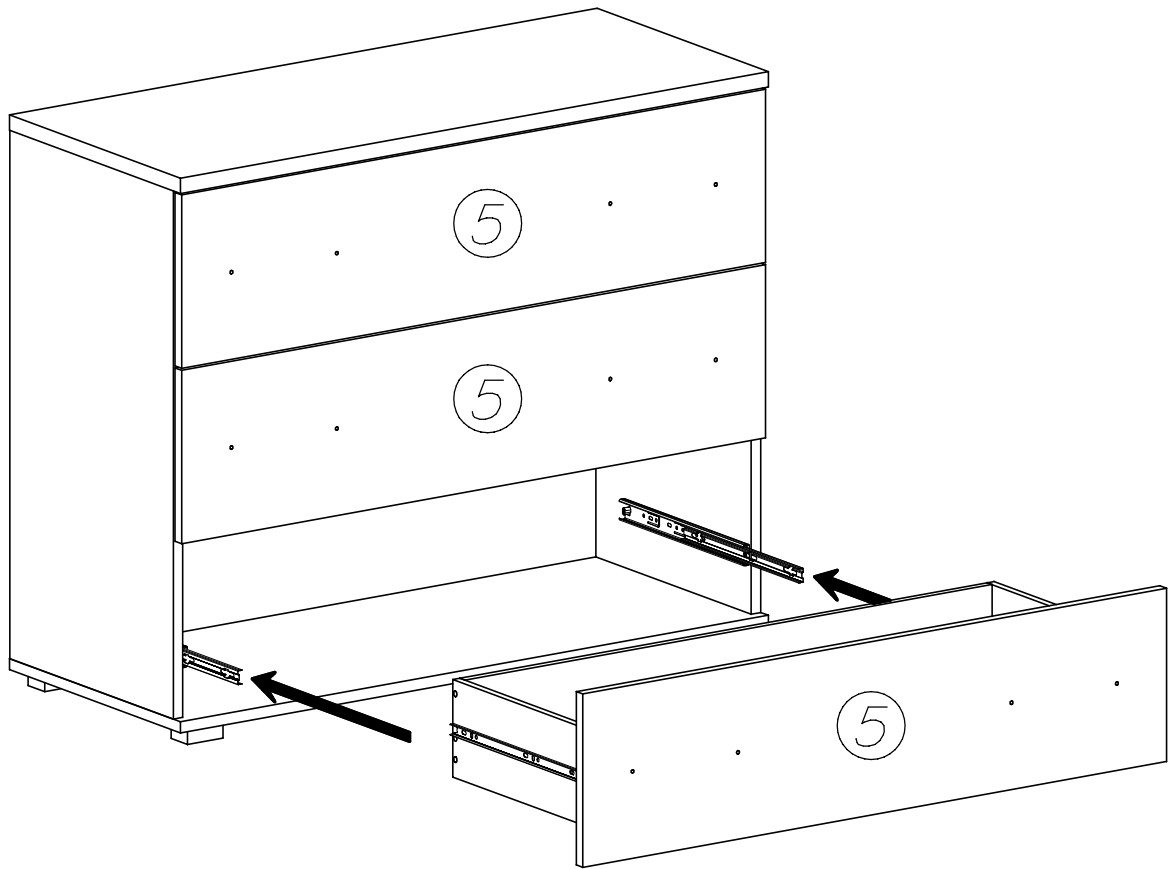
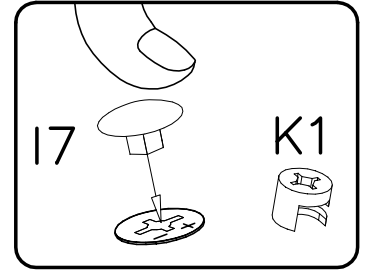
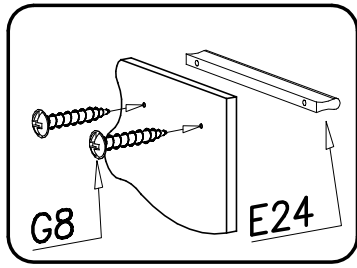



Achtung • Opgelet • Uwaga • Dikkat • Вниманіе •
Attention • Upozorneni • Figyelem • Allenzione • Atentie



D	Überschreiten Sie die angegebenen Maximalbelastungen nicht. Andernfalls kann das Möbelstück beschädigt oder zerstört werden.
GB	Do not exceed the maximum loads specified. Otherwise, the furniture may sustain damage or be irreparably damaged.
NL	Overschrijd de aangegeven maximale belastingen niet. Anders kan het meubelstuk worden beschadigd of vernield.
PL	Nie wolno przekraczać podanych maksymalnych wartości obciążenia. W innym przypadku można mebel uszkodzić lub zniszczyć.
TR	Belirtilen azami yuk degerini asmayiniz, aksi taktirde mobilya parçasi zarar gorebilir veya kullanilamaz hale gelebilir.
RU	Не допускается превышение указанных максимальных нагрузок. В противном случае возможно повреждение или разрушение мебели.
FR	Ne dépassez pas les charges maximum indiquées. Sinon, le meuble peut être endommagé ou détruit.
CZ	Nepřekračujte uvedená maximální zatížení. V opačném případě může dojít k poškození nebo zničení nábytku.
HU	Tartsa be az engedélyezett maximális terhelhetőséget/teljesítményt. Különböző a bútor és annak alkatrészei megsérülhetnek, tönkremehetnek.
IT	Non superare il carico massimo indicato. Altrimenti il mobile rischia di rovinarsi o frantumarsi.
RO	Nu depasiti sollicitarile maxime specificate. Altfel puteti sa deteriorati sau sa distrugeti piesa de mobilier.
SK	Neprekročte uvedené maximálne zaťaženia. V opačnom prípade sa môže nábytok poškodiť alebo zničiť.

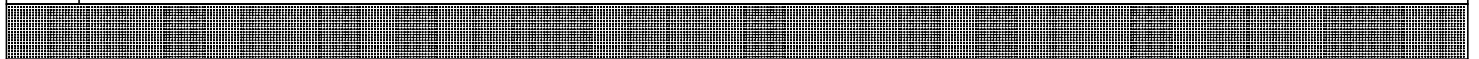

D	Die Befestigung des Möbelstückes an der Wand muss von einer fachkundigen Person vorgenommen werden, da für die Montage an die Wand angepasste Dübel erforderlich sind.
GB	A qualified professional is required when mounting furniture to the wall since dowels corresponding to the wall are required for this.
NL	Een vakkundige persoon dient het meubelstuk aan de muur te bevestigen; voor de montage aan de muur zijn immers aangepaste pluggen vereist.
PL	Mocowanie mebla do ściany mogą przeprowadzić wyłącznie wykwalifikowane osoby, z uwagi na zastosowanie odpowiednio dopasowanych kołków do rodzaju ściany.
TR	Mobilya parçasının duvara sabitlenmesi, duvar montajı için özel uyarılanmış dübeller gerektirdiğinden bu iş sadece bu konuda uzman bir kişi tarafından gerçekleştirilmelidir.
RU	Поскольку для монтажа на стене необходимо использовать специальные дюбели, мебель должна быть закреплена на стене квалифицированным персоналом.
FR	La fixation du meuble contre le mur doit être effectuée par une personne compétente car, pour le montage mural, il faut utiliser des chevilles adaptées.
CZ	Montáž nábytku na stěnu musí provést odborník, protože k montáži na stěnu jsou zapotřebí upravené hmoždinky.
HU	A bútorelemek falra rögzítését szakembernek kell végeznie, mert a rögzítéshez megfelelő tiplit kell használni.
IT	Il fissaggio del mobile alla parete deve essere eseguito esperte, dato che occorrono tasselli adeguati.
RO	Fixarea la perete a piesei de mobilier se realizeaza numai de catre personal competent, deoarece montajul de perete necesita dibluri adecvate.
SK	Upevnenie nábytku na stenu musí vykonať odborník, nakoľko sú pre montáž na stenu potrebné vhodné hmoždinky.

