

finori GmbH
 Straßäcker 2
 D - 96253 Untersiemau

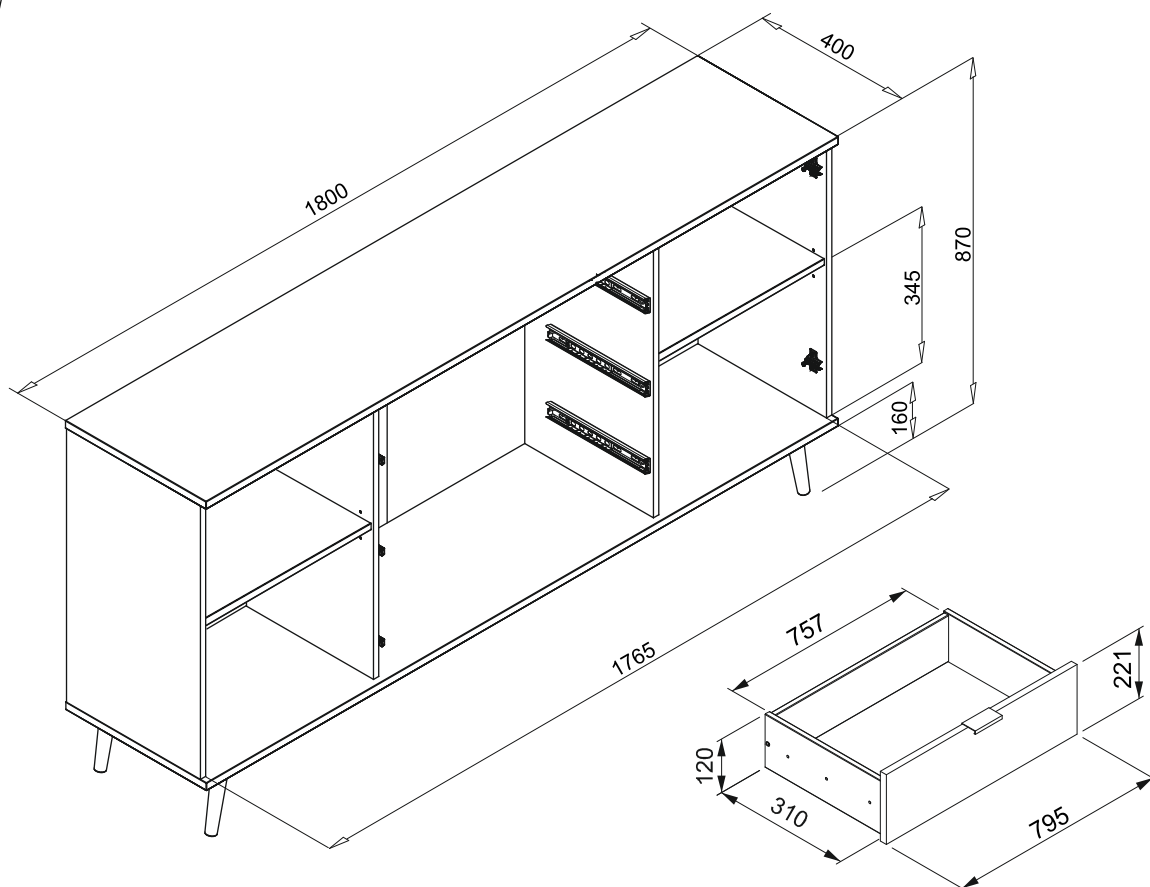

FR

**Pensez à
 donner ou recycler.**

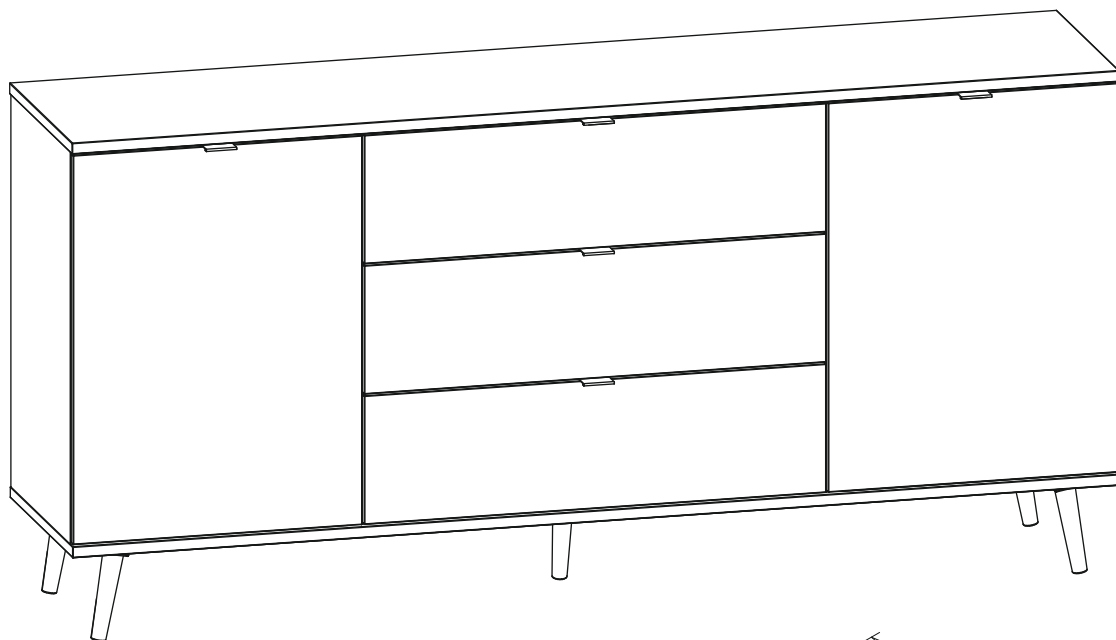

Association

ou



Magasin

ou



Déchèterie

<https://quefairedemesdechets.fr>



- Ⓓ Befolgen Sie stets die Anleitung des Herstellers!
- ⒸⒺ Please generally follow the manufacturer's instructions!
- ⒻⒼ Suivez toujours les instructions du fabricant!
- ⒼⒹ Volg steeds de handleiding van de producent!
- ⒺⒶ Siga siempre las instrucciones del fabricante!
- ⒶⒻ Stale przestrzegaj instrukcji producenta!

- ⒶⒶ Всегда следуйте инструкции производителя!
- ⒶⒶ Seguire sempre le istruzioni del produttore!
- ⒶⒶ Mindig tartsa be a gyártó utasításait!
- ⒶⒶ Siga sempre as instruções do fabricante!
- ⒶⒶ Vždy dodržujte pokyny výrobce!



- Ⓓ Verwenden Sie zur Reinigung nur ein feuchtes Tuch!
- ⒸⒺ Please only clean with a damp cloth!
- ⒻⒼ N'utilisez qu'un chiffon humide pour le nettoyage!
- ⒼⒹ Gebruik voor de reiniging enkel een vochtige doek!
- ⒺⒶ Para limpiar utilice sólo un paño húmedo!
- ⒶⒻ Do czyszczenia używaj wilgotnej szmatki!

- ⒶⒶ Для очистки используйте только влажную ткань!
- ⒶⒶ Per la pulizia, utilizzare solo un panno umido!
- ⒶⒶ A tisztításhoz elegendő egy nedves kendő használatát!
- ⒶⒶ Para a limpeza use apenas um pano húmido!
- ⒶⒶ Pro čištění používejte pouze vlhký hadřík!

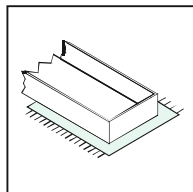

- Ⓓ Bauen Sie das Produkt auf einer Unterlage auf!
- ⒸⒺ Please mount the product on a bottom support!
- ⒻⒼ Montez le produit sur une base!
- ⒼⒹ Monteer het product op een basis!
- ⒺⒶ Monte el producto sobre una base!
- ⒶⒻ Rozkładaj produkt na podkładce!

- ⒶⒶ Собирайте изделие на подстилке!
- ⒶⒶ Montare il prodotto su un supporto!
- ⒶⒶ Az összeszereléskor helyezzen a termék alá megfelelő alátétet!
- ⒶⒶ Monte o produto numa superfície plana!
- ⒶⒶ Výrobek smontujte na pevném podkladu!

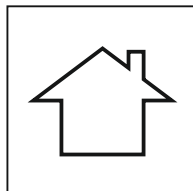

- Ⓓ Verwenden Sie das Produkt nur in Innenräumen!
- ⒸⒺ Please exclusively use the product indoors!
- ⒻⒼ N'utilisez le produit qu'à l'intérieur!
- ⒼⒹ Gebruik het product enkel binnenshuis!
- ⒺⒶ Utilice el producto sólo en interiores!
- ⒶⒻ Używaj produkt tylko w pomieszczeniach wewnętrznych!

- ⒶⒶ Используйте изделие только во внутренних помещениях!
- ⒶⒶ Utilizzare il prodotto solo in ambienti interni!
- ⒶⒶ A termék csak bel terekben használható!
- ⒶⒶ Use o produto apenas no interior!
- ⒶⒶ Používejte výrobek pouze uvnitř!

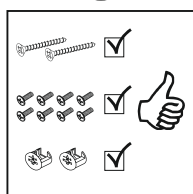

- Ⓓ Legen Sie die Beschläge zusammen und prüfen Sie die Vollständigkeit!
- ⒸⒺ Please join the fittings and verify their completeness!
- ⒻⒼ Pliez les raccords ensemble et vérifiez qu'ils sont complets!
- ⒼⒹ Leg de onderdelen samen en controleer de volledigheid!
- ⒺⒶ Junte los accesorios y compruebe que están todos!
- ⒶⒻ Rozlož poszczególne części i sprawdź kompletność!

- ⒶⒶ Положите фурнитуру в одно место и проверьте комплектность!
- ⒶⒶ Mettere insieme le guarnizioni e verificarne la completezza!
- ⒶⒶ Állítsa össze a sarokvasakat, és ellenőrizze, hogy épek-e!
- ⒶⒶ Coloque os encaixes juntos e verifique se estão completos!
- ⒶⒶ Složte armatury a zkontrolujte úplnost!

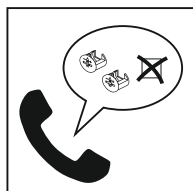

- Ⓓ Bei fehlenden Teilen kontaktieren Sie den Hersteller!
- ⒸⒺ If parts are missing, please turn to the manufacturer!
- ⒻⒼ En cas de pièces manquantes, veuillez contacter le fabricant!
- ⒼⒹ Contacteer de fabrikant als er onderdelen ontbreken!
- ⒺⒶ En el caso de que falten piezas, póngase en contacto con el fabricante!
- ⒶⒻ W razie braku części skontaktuj się z producentem!

- ⒶⒶ При отсутствии каких-либо частей обратитесь к производителю!
- ⒶⒶ In caso di pezzi mancanti, contattare il produttore!
- ⒶⒶ Ha hiányozna valamelyik elem, lépjen kapcsolatba a gyártóval!
- ⒶⒶ Em caso de peças em falta, entre em contato com o fabricante!
- ⒶⒶ Pro chybějící díly kontaktujte výrobce!

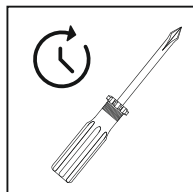

- Ⓓ Ziehen Sie die Schrauben nach einiger Zeit des Gebrauchs erneut fest!
- ⒸⒺ Please re-tighten the screws after having used the product for a while!
- ⒻⒼ Resserrer les vis après un certain temps d'utilisation!
- ⒼⒹ Draai de schroeven na een zekere gebruikstijd opnieuw vast!
- ⒺⒶ Asegure de nuevo los tornillos tras usarlo durante un tiempo!
- ⒶⒻ Po pewnym czasie użytkowania ponownie dokręć śruby!

- ⒶⒶ Спустя некоторое время использования подкрутите гайки!
- ⒶⒶ Stringere nuovamente le viti dopo un certo periodo di utilizzo!
- ⒶⒶ A használat során némi idő elteltével húzza meg újra a csavarokat!
- ⒶⒶ Reaperte os parafusos após algum tempo de uso!
- ⒶⒶ Po určité době používání šrouby znovu utáhněte!

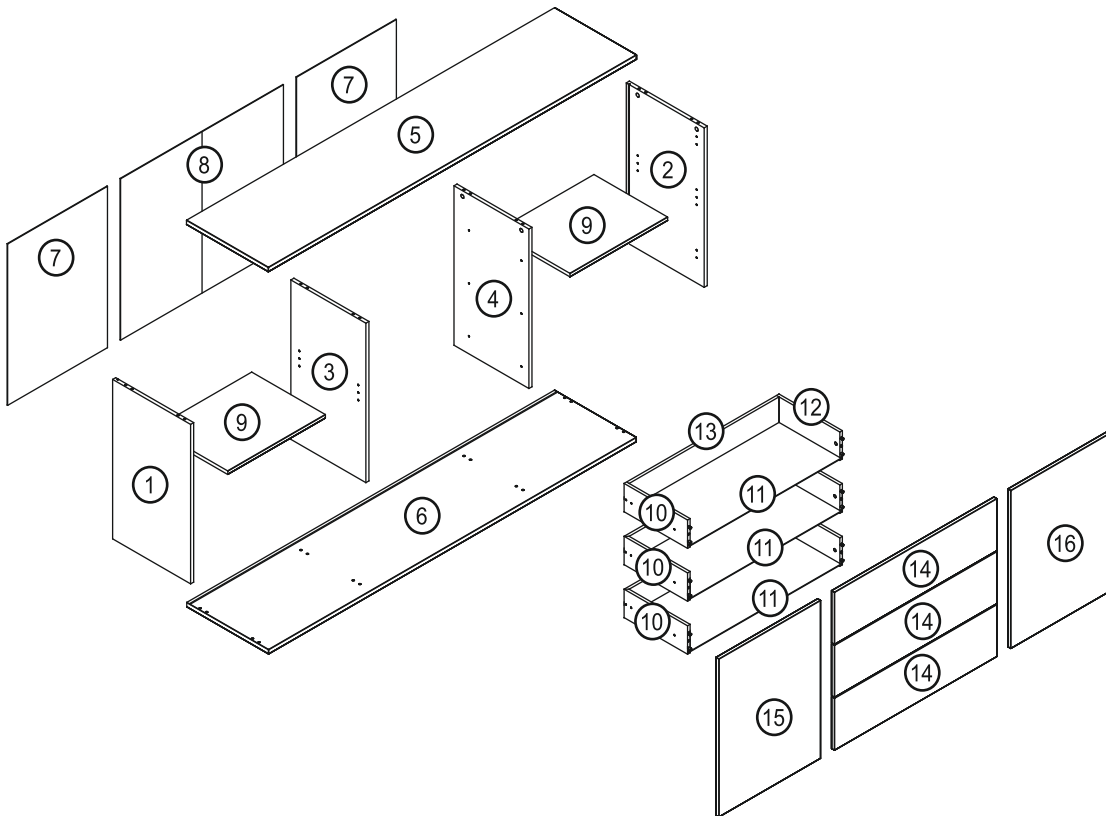
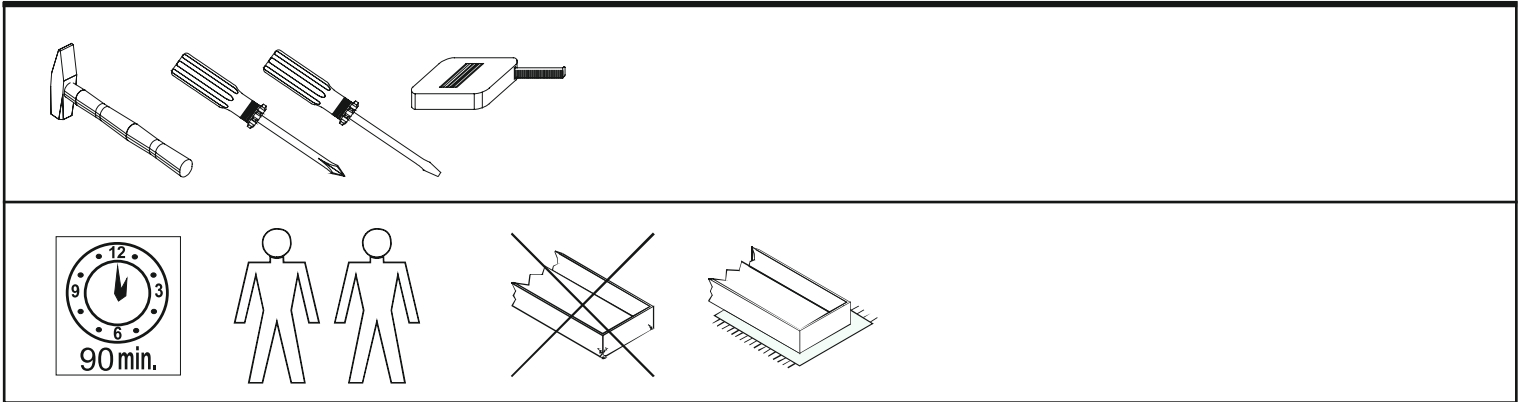

Dimensions / Abmessung in mm/		
①	1	675 x 382 x 16
②	1	675 x 382 x 16
③	1	675 x 364 x 16
④	1	675 x 364 x 16
⑤	1	1800 x 400 x 18
⑥	1	1800 x 400 x 18
⑦	2	685 x 489 x 2,5
⑧	1	685 x 796 x 2,5
⑨	2	478 x 359 x 16
⑩	3	310 x 120 x 16
⑪	3	735 x 315 x 2,5
⑫	3	310 x 120 x 16
⑬	3	725 x 105 x 16
⑭	3	795 x 221 x 16
⑮	1	669 x 496 x 16
⑯	1	669 x 496 x 16

BOX 1	5, 6, 10, 12, 13, 14
BOX 2	1, 2, 3, 4, 7, 8, 9, 11, 15, 16



BOX 1	✓
BOX 2	

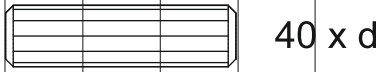

40 x d

6 x v



14 x b

14 x a

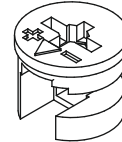

14 x c

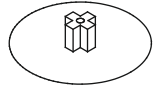

14 x e

12 x m

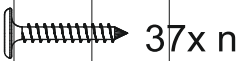
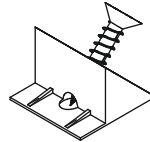

37 x n

8 x f

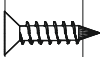
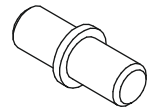

54 x d10

5 x j58

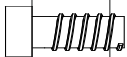
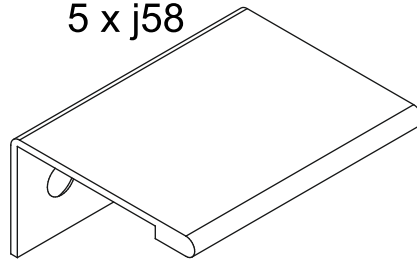

8 x d5

5 x q

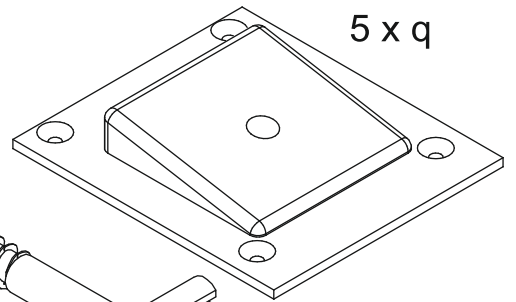

1 x p

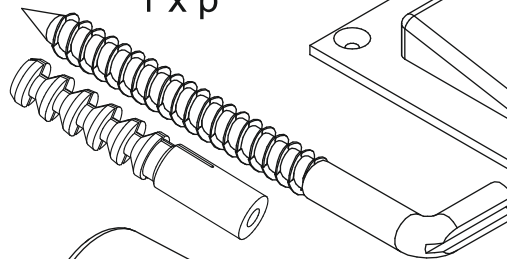

8 x u

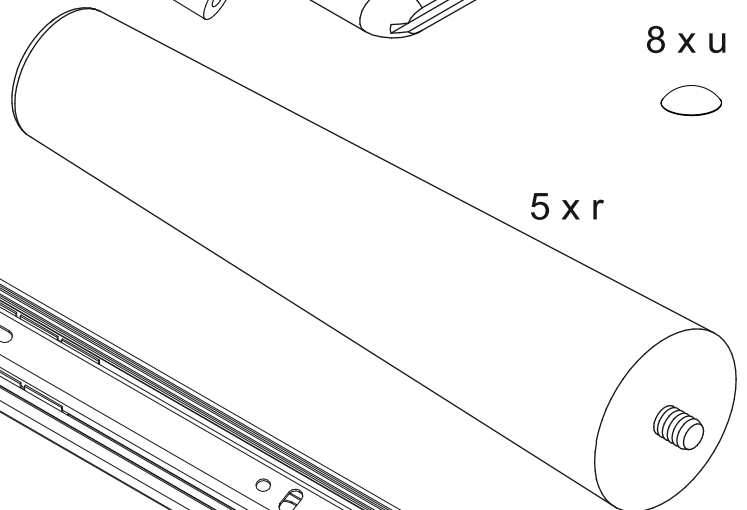

4 x j

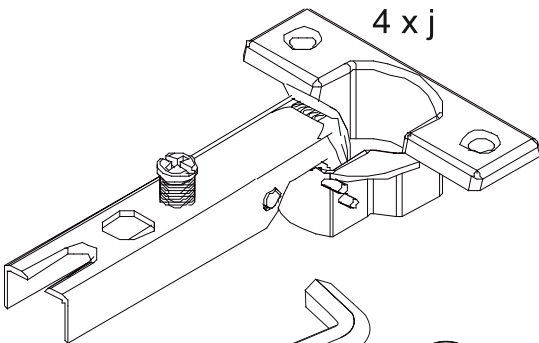

5 x r

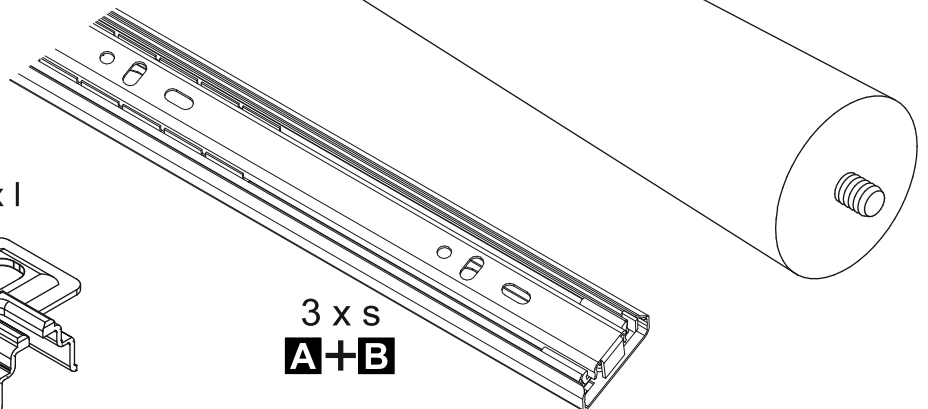

4 x l

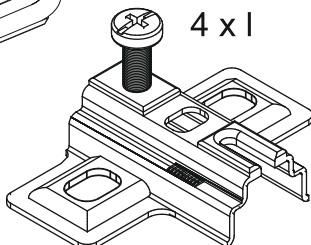





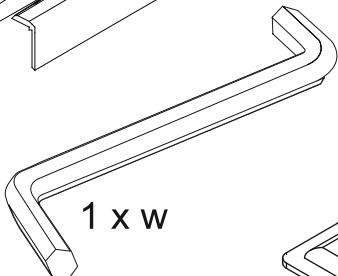

3 x s

A+B

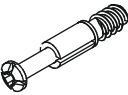
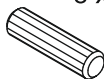
1 x w

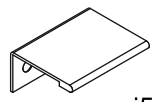

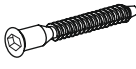
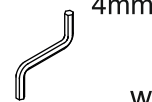

A **3 x**

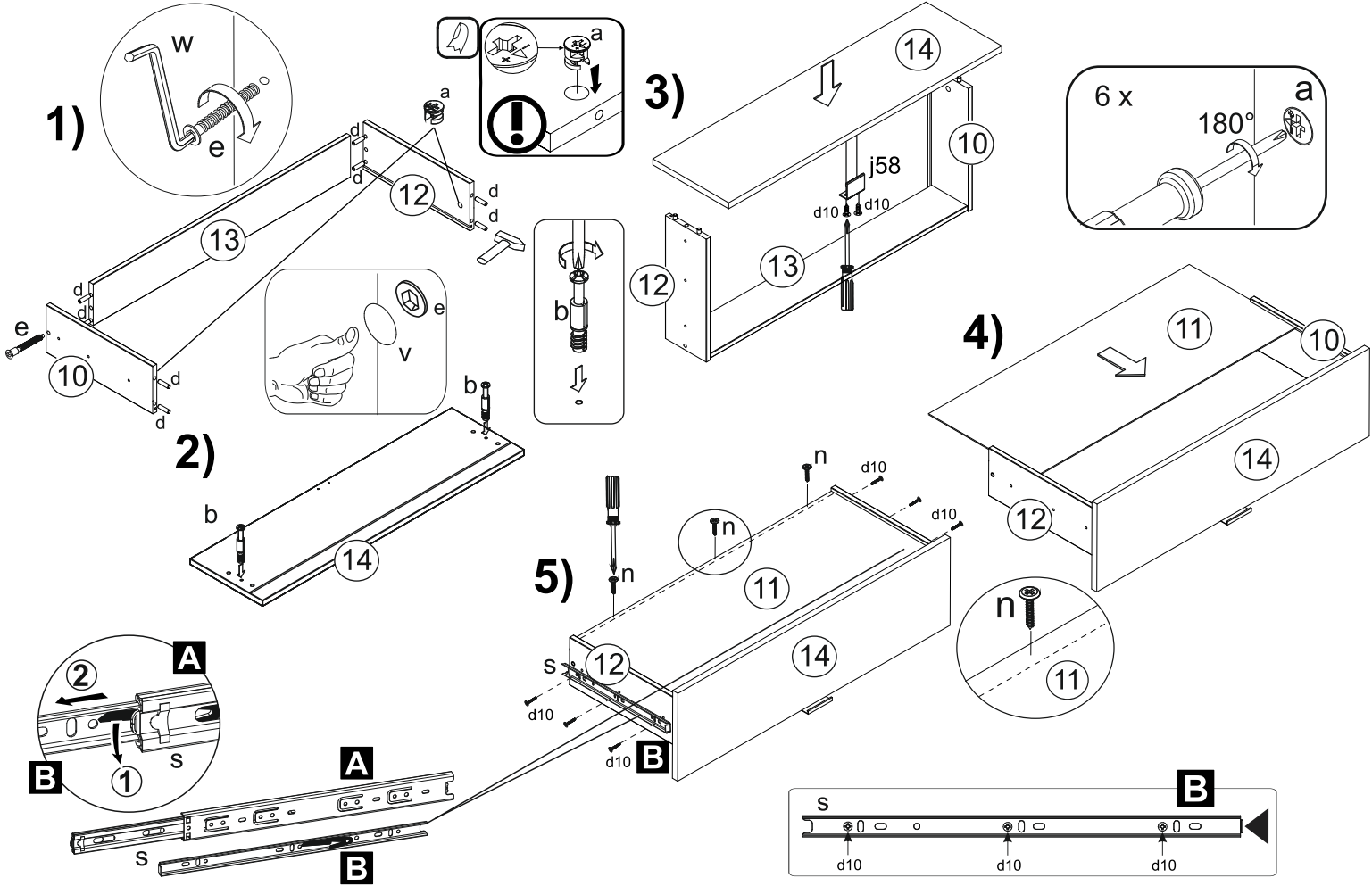
6 x  b	24 x  d	300 mm 6 x  A+B s	24x  d10	3 x  j58
9 x  n	6 x  a	6 x  v	6 x  e	1 x  w

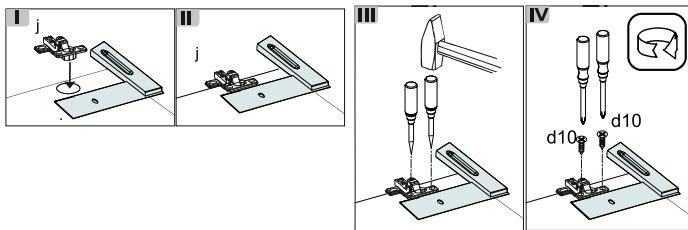

B

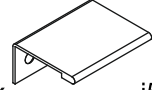
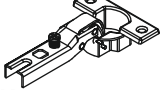

12x  d10	2 x  j58	4 x  j
-----------------------------------------------------------------------------------------------------	------------------------------------------------------------------------------------------------------	----------------------------------------------------------------------------------------------------

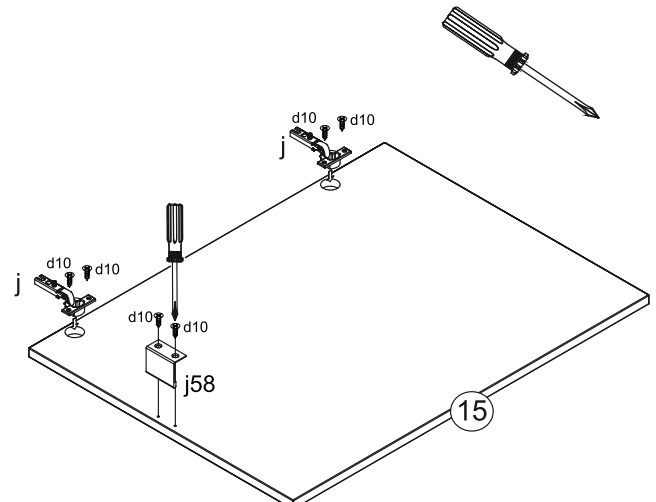
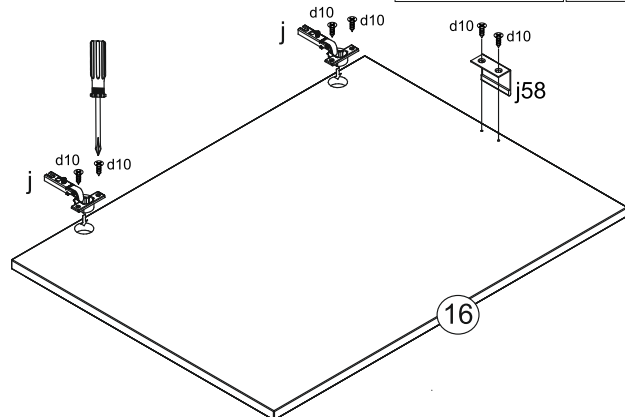

C

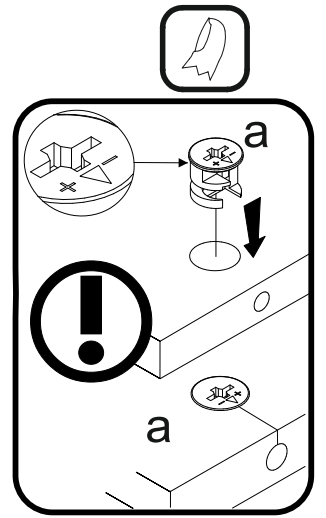
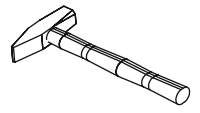
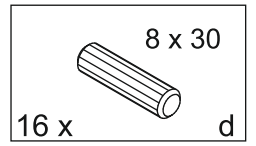
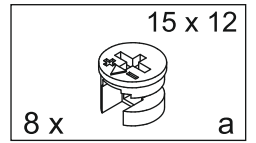
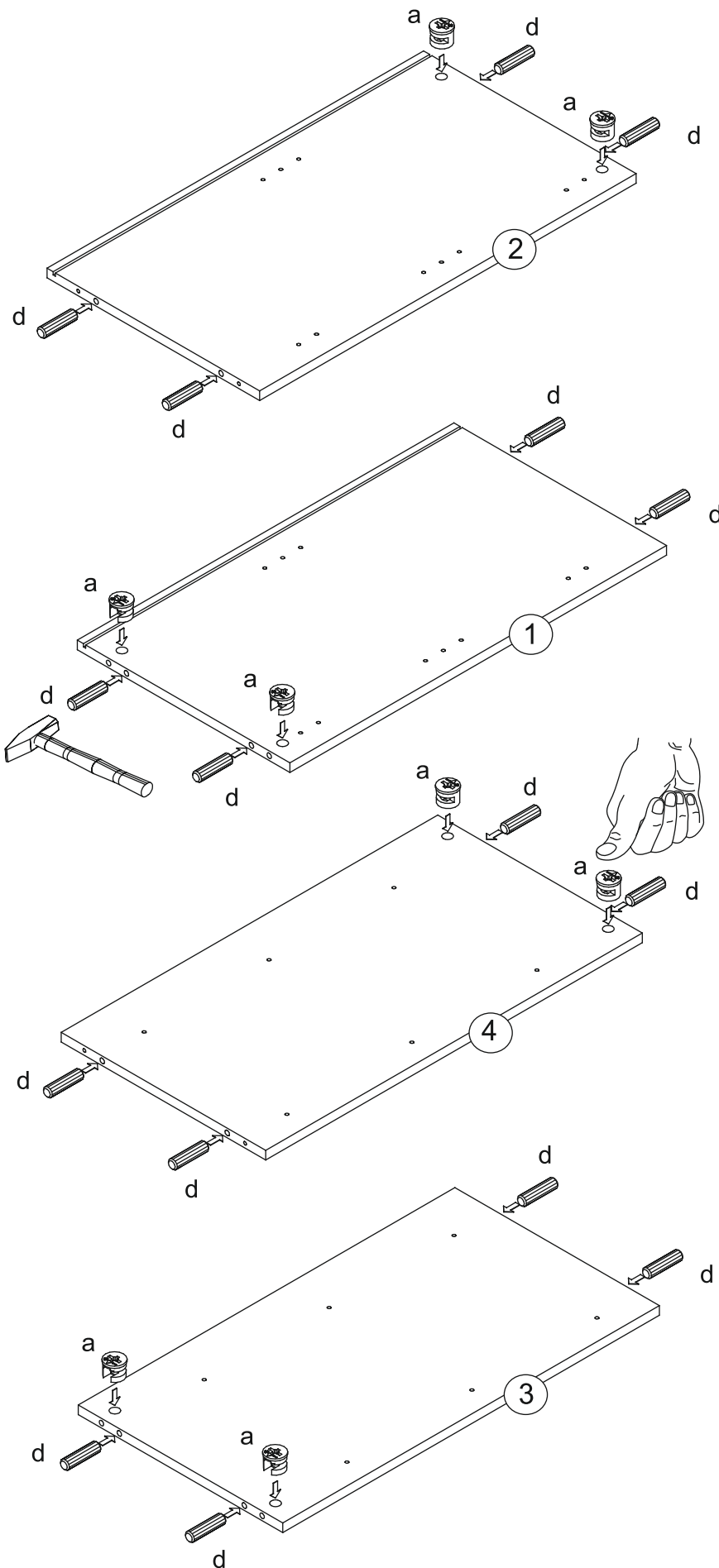

D

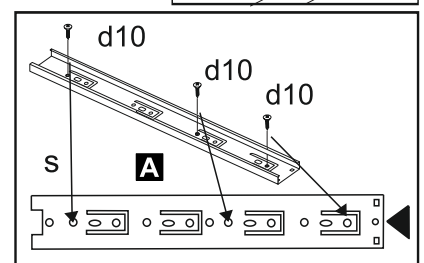
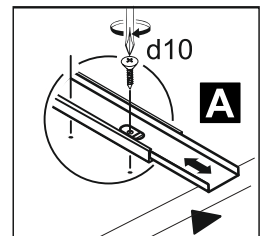
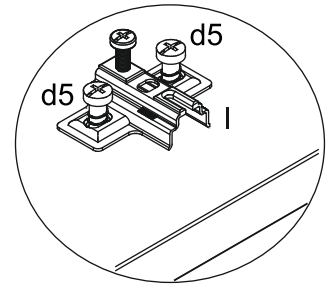
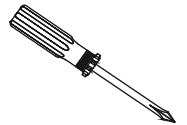
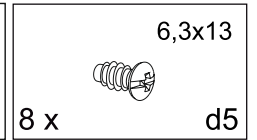
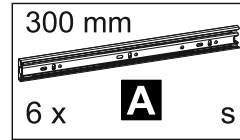
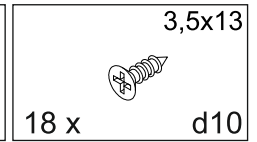
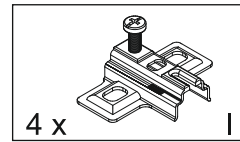
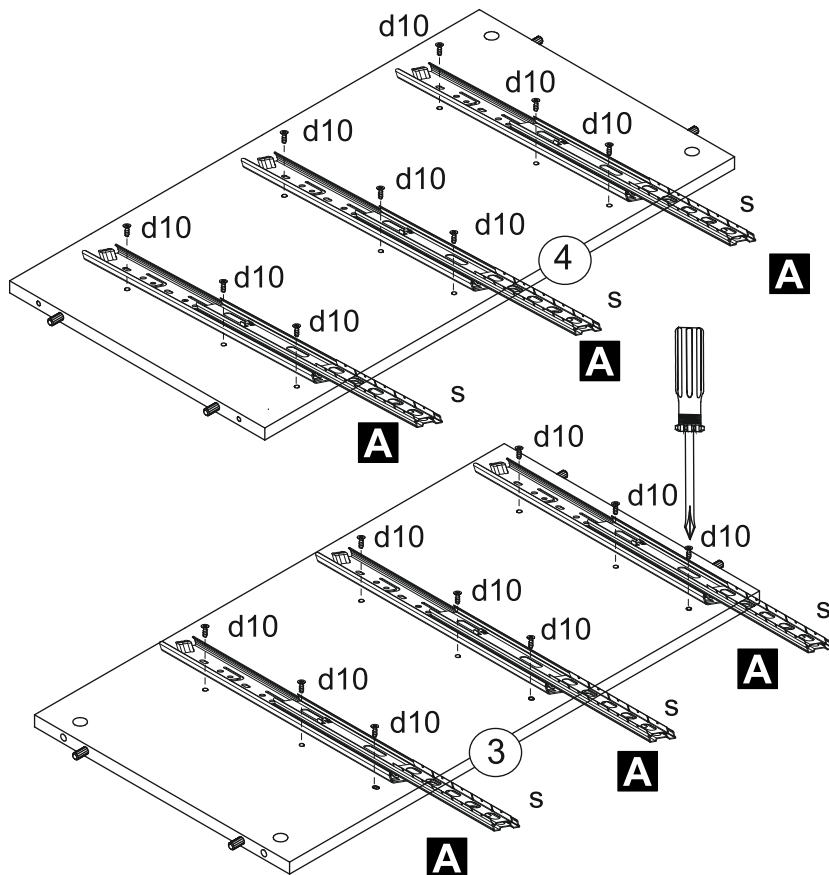
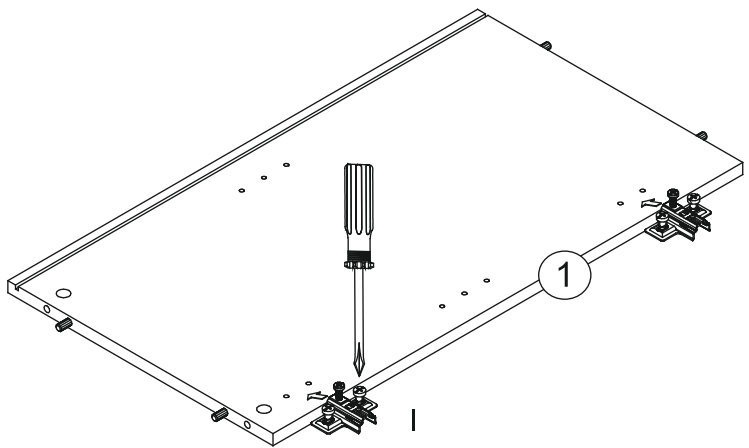
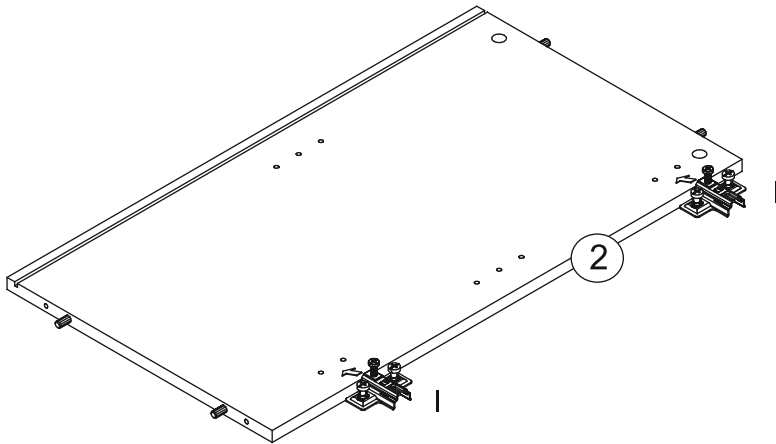

E

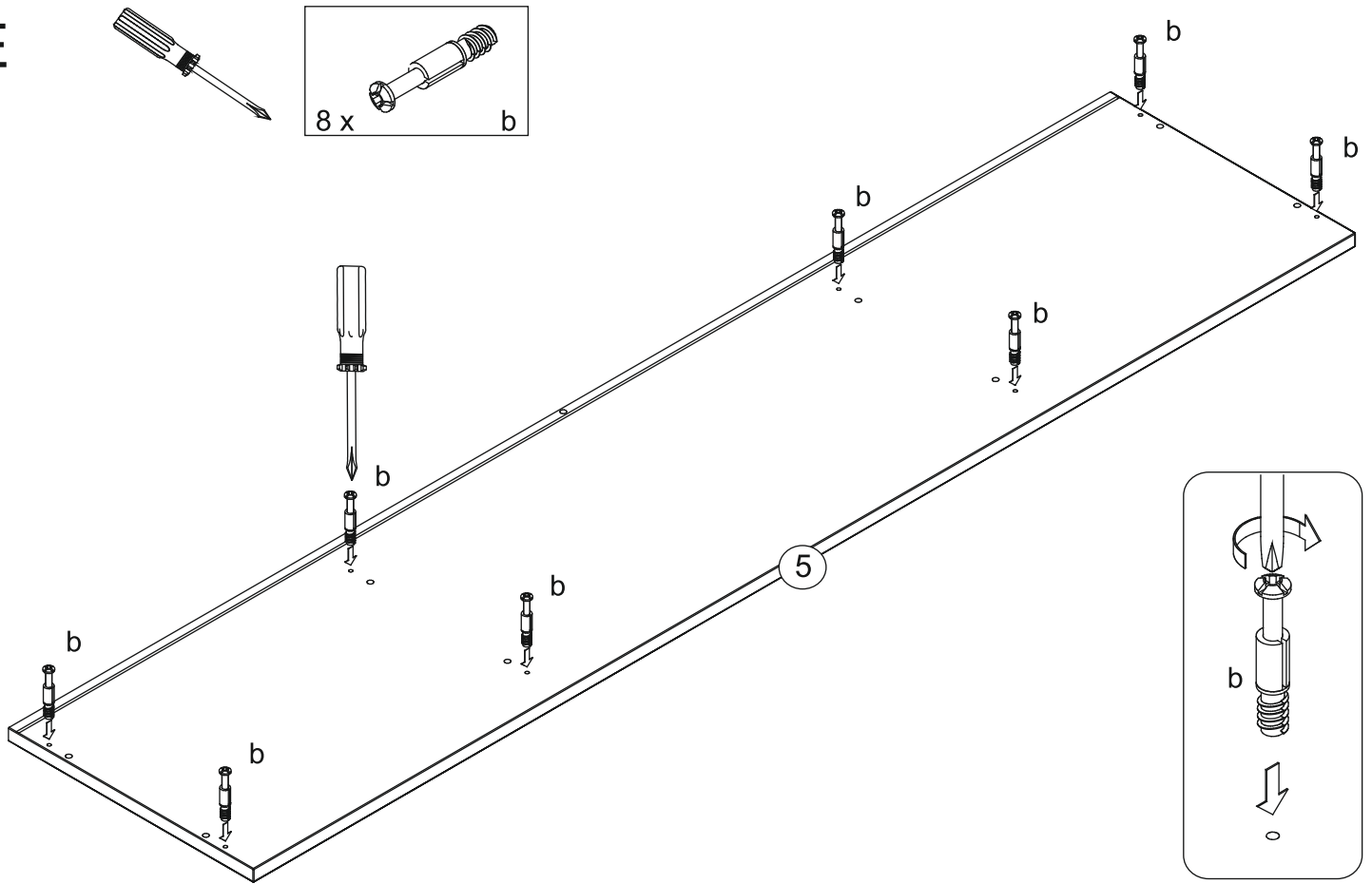

F

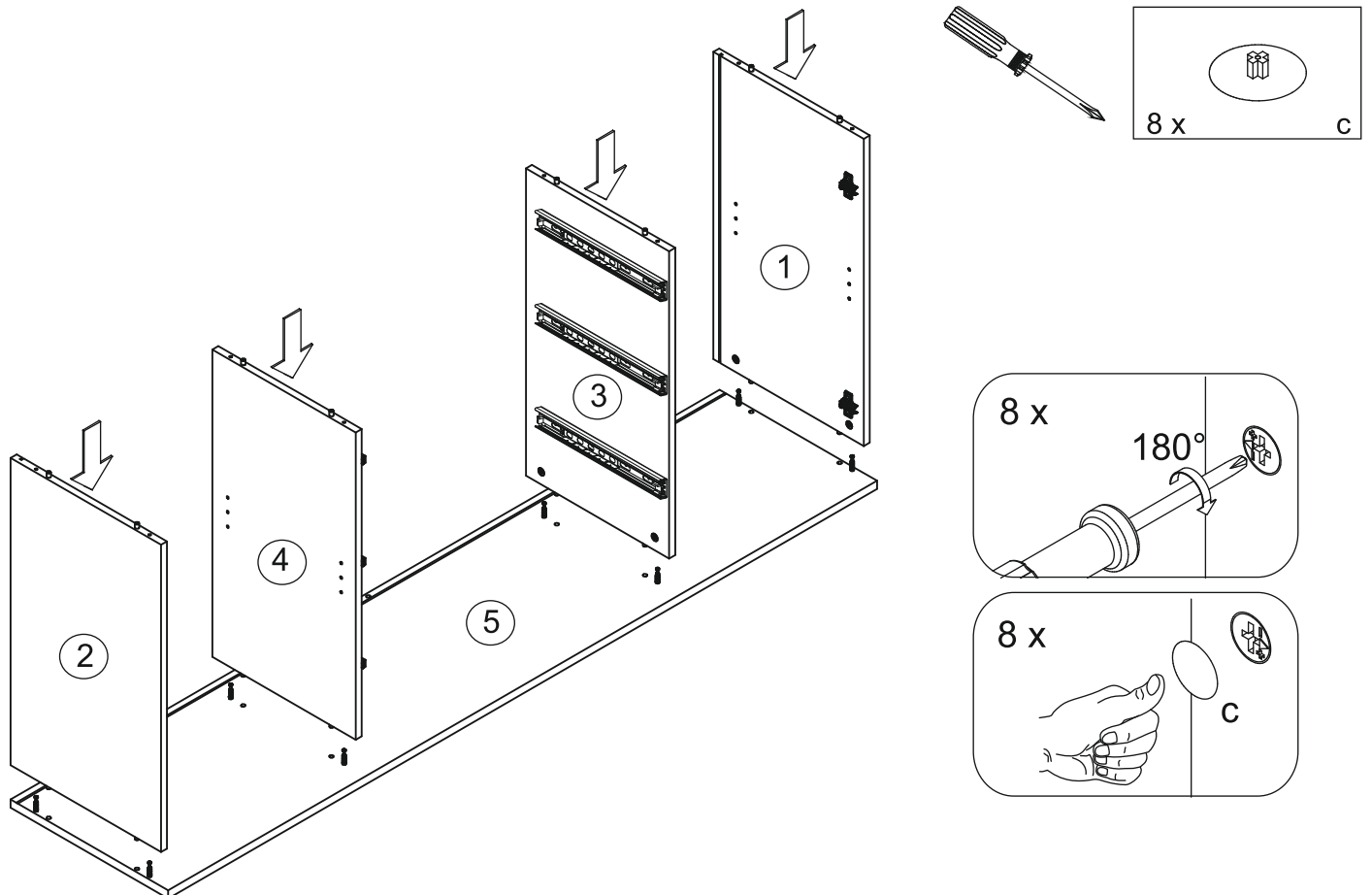

G

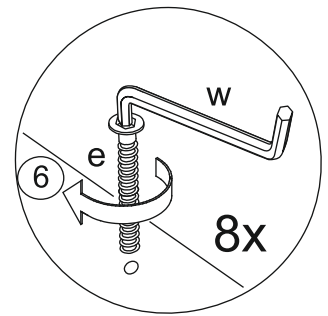
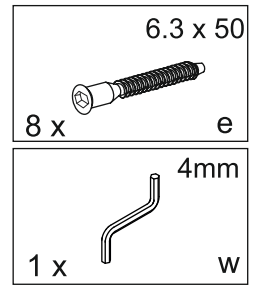
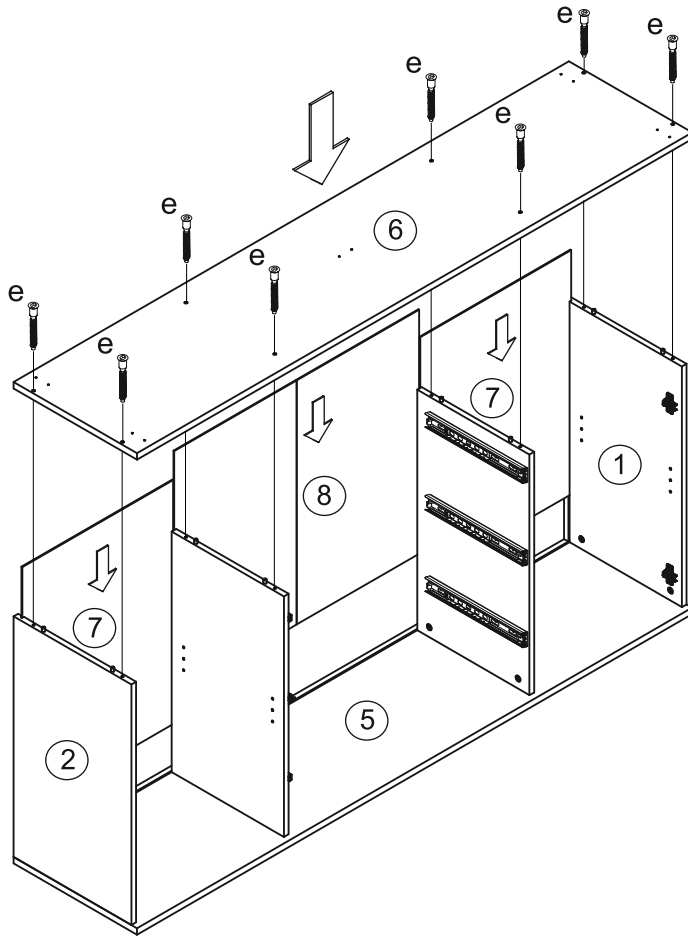

H

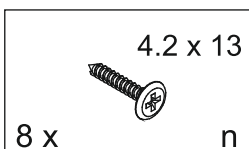
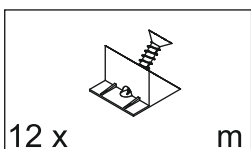
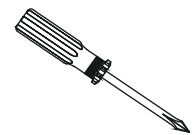
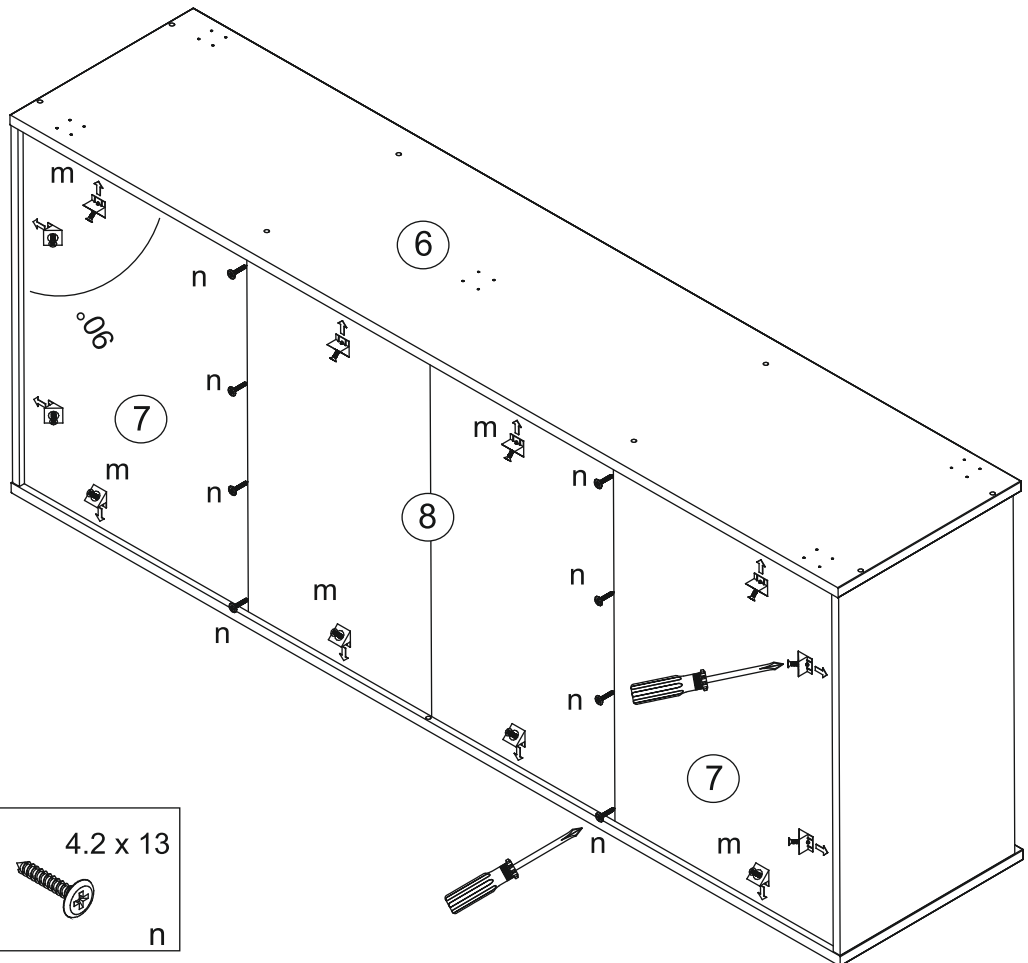

I

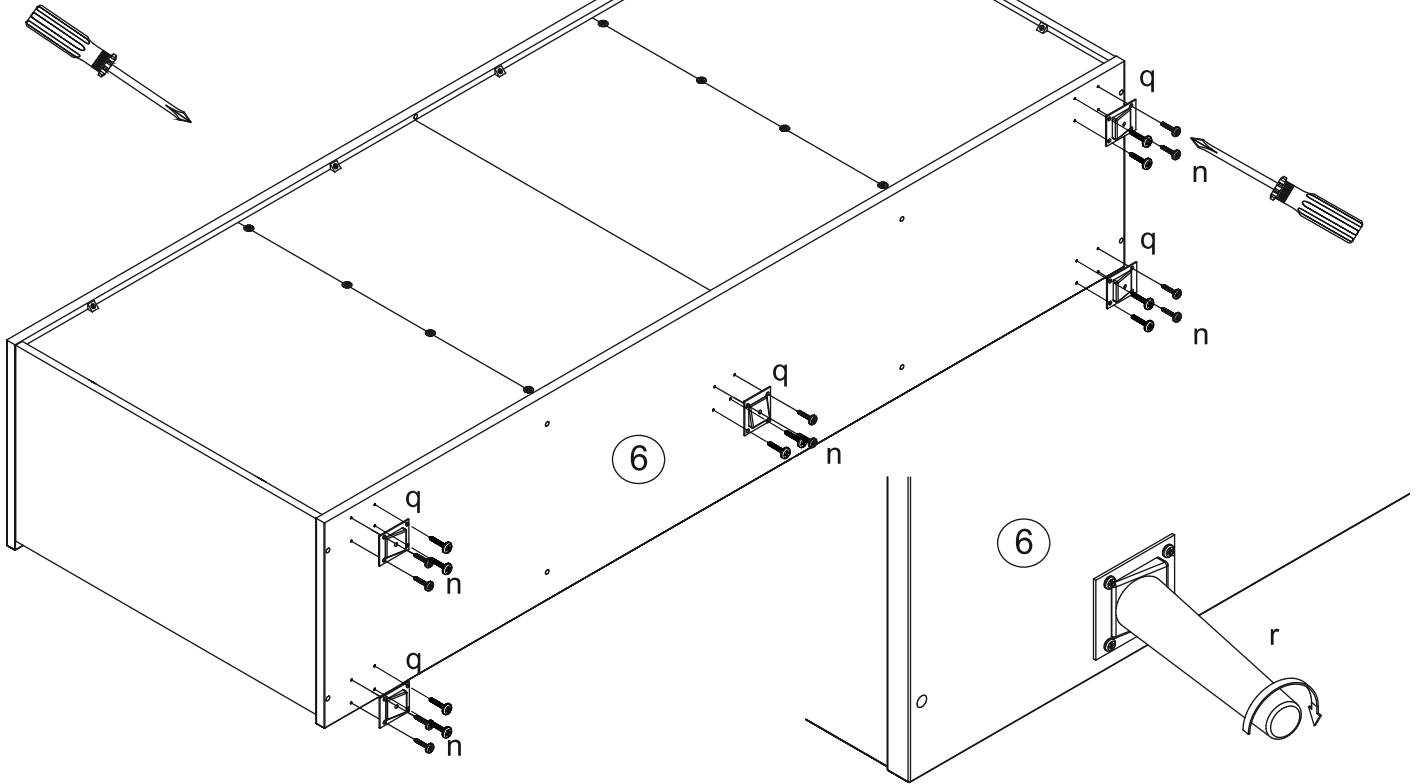
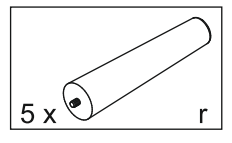
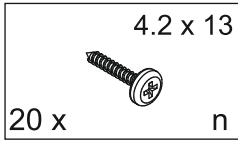
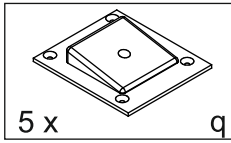

J

Le meuble doit être fixé au mur!
 Das Möbel muss an der Wand befestigt werden!
 This unit must be secured to a wall
 using suitable fixing (not supplied)

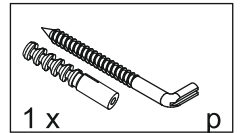

***Attention!**

Veillez-vous informer sur le type de cheville et vis approprié à la nature de votre mur.

***Achtung!**

Ivforuier ev Sie sih Àor der Wavduovtage uer das ge eigvete Movtageuaterial für Ihre Wavd!

***Caution!**

Please ivforu yourself aout uovtvg uaterial suiteale for your Áall efore uovtvg.

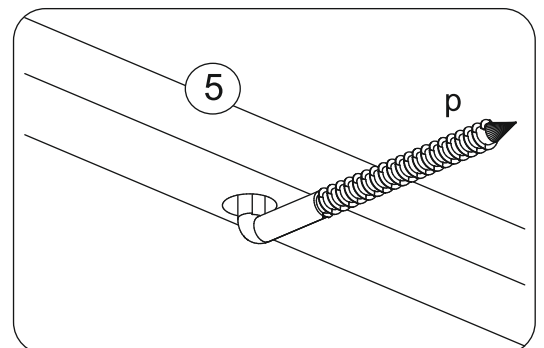
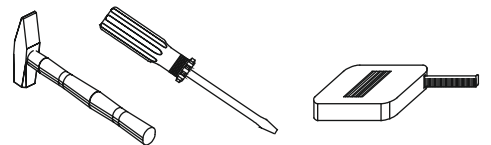
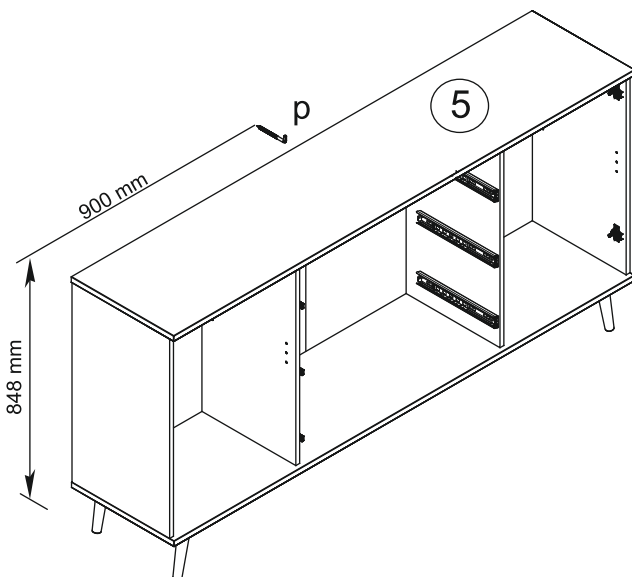

K

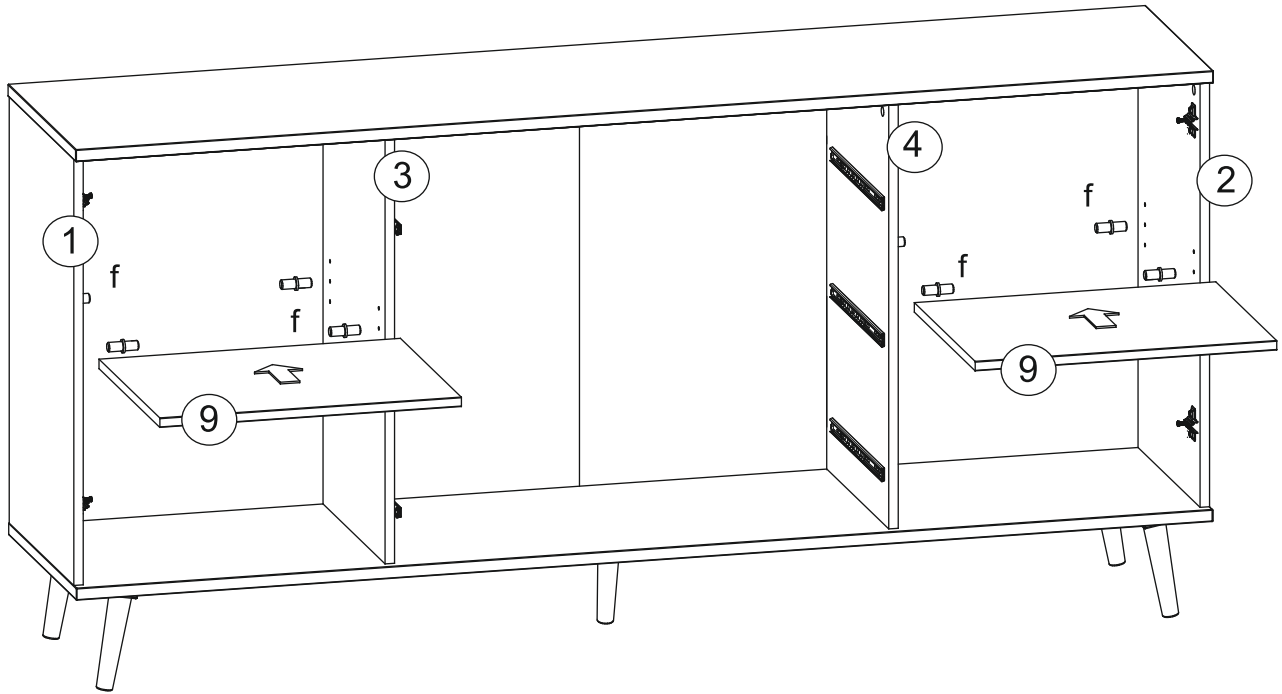
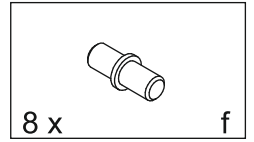

L

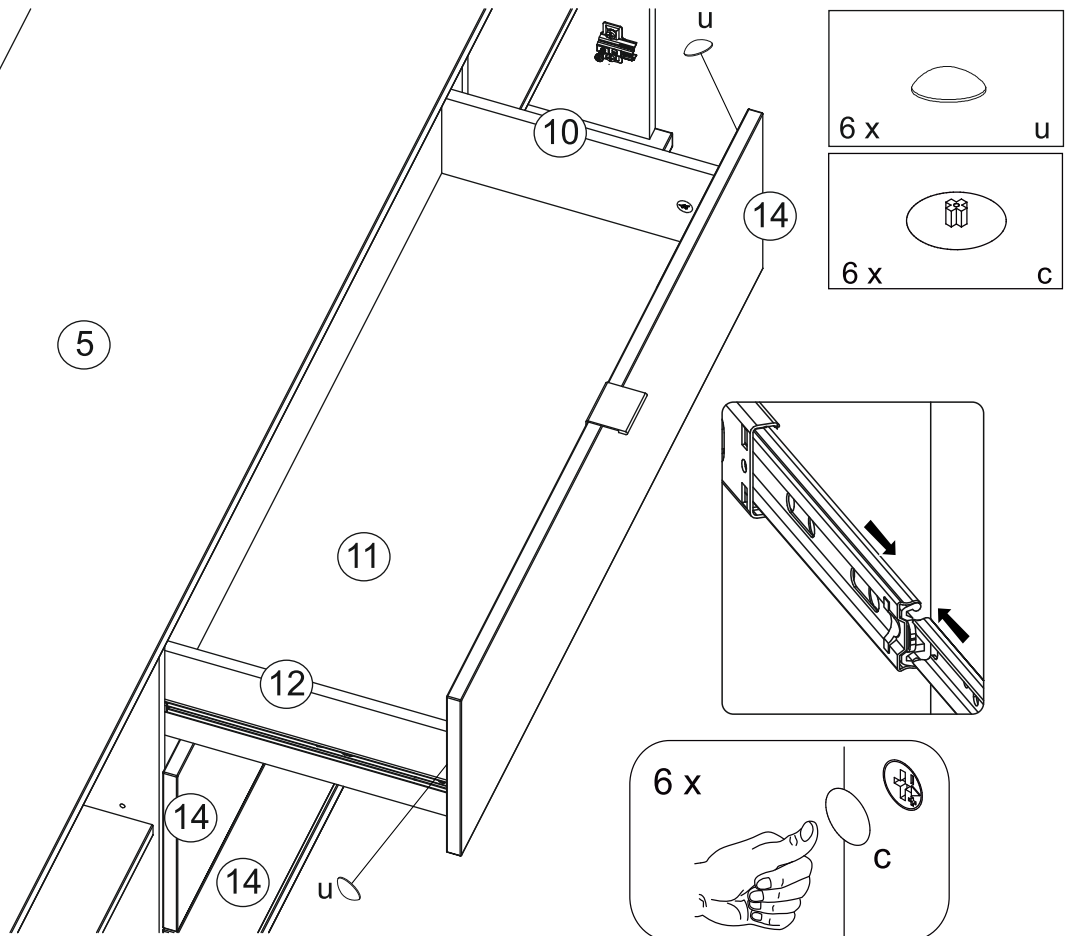

M

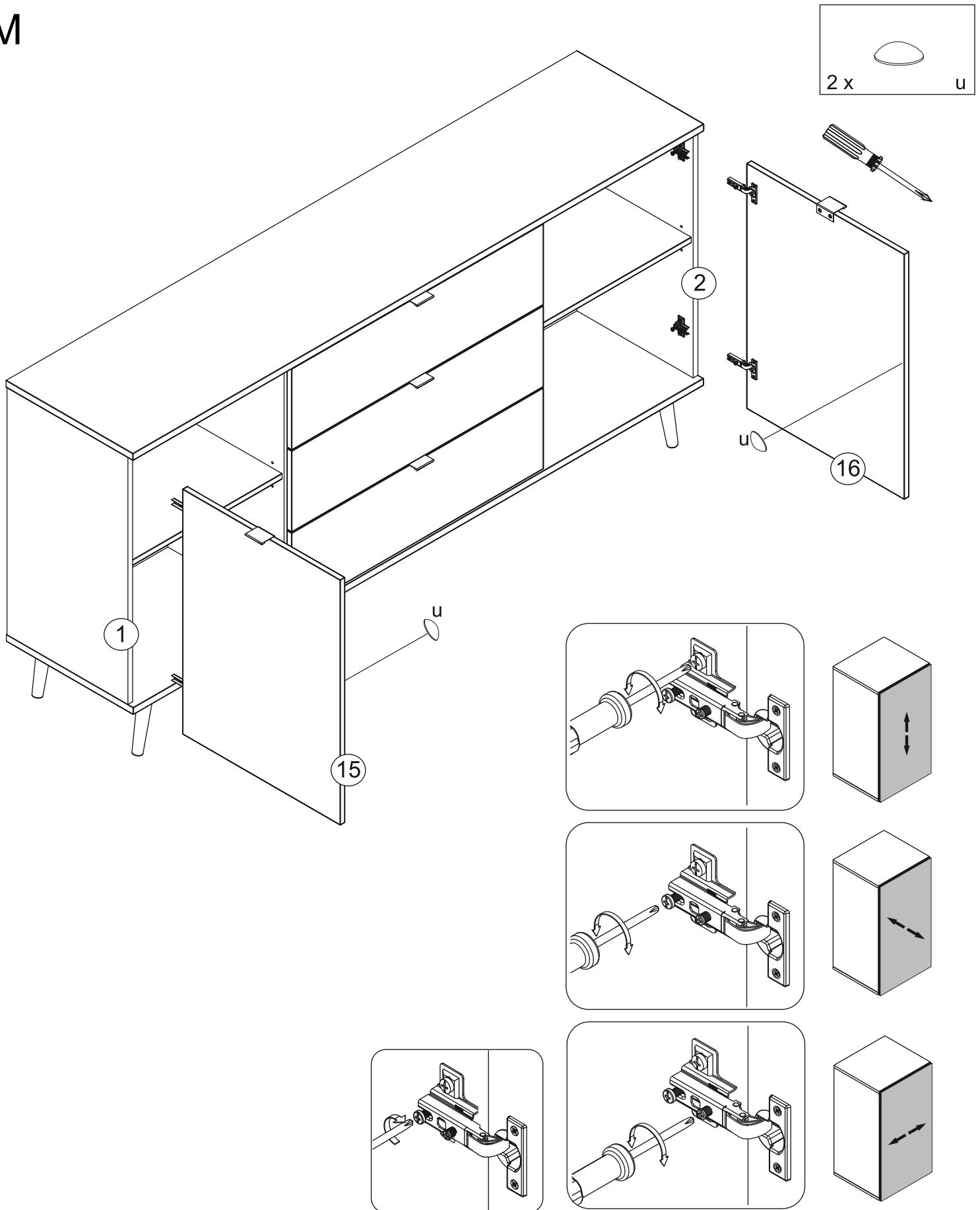



- Ⓓ Das Möbel muss an der Wand befestigt werden!
- Ⓖ Please ensure to mount the furniture to the wall!
- Ⓕ Les meubles doivent être fixés au mur!
- Ⓝ Het meubel moet aan de wand worden vastgemaakt!
- Ⓔ El mueble se tiene que fijar a la pared!
- Ⓟ Mebel należy przymocować do ściany!



- Ⓓ Informieren Sie sich vor der Wandmontage über das geeignete Montagematerial!
- Ⓖ Please get informed on suitable assembly materials before commencing the wall-mounting!
- Ⓕ Renseignez-vous sur le matériel de montage approprié avant le montage mural!
- Ⓝ Informeer u voor de wandmontage over het geschikte montagematerieel!
- Ⓔ Infórmese antes del montaje en la pared del material apropiado de montaje!
- Ⓟ Przed montażem na ścianie upewnij się, jaki jest potrzebny właściwy materiał montażowy!



- Ⓓ Beschaffen Sie sich das angemessene Material zur Wandbefestigung!
- Ⓖ Please obtain suitable wall-mounting materials!
- Ⓕ Procurez-vous le matériel approprié pour le montage mural!
- Ⓝ Verschaf u het adequate materieel voor de wandbevestiging!
- Ⓔ Procúrese el material adecuado para la fijación a la pared!
- Ⓟ Zakup odpowiedni materiał do przymocowania na ścianie!



- Ⓓ Lassen Sie die Wandbefestigung von einer fachkundigen Person vornehmen!
- Ⓖ Ensure all wall-mounting is carried out by competent personnel!
- Ⓕ Faites effectuer le montage mural par une personne compétente!
- Ⓝ Laat de wandbevestiging door een professional uitvoeren!
- Ⓔ Deje que la fijación a la pared la haga un profesional!
- Ⓟ Zleć przymocowanie do ściany odpowiednio doświadczonej osobie!

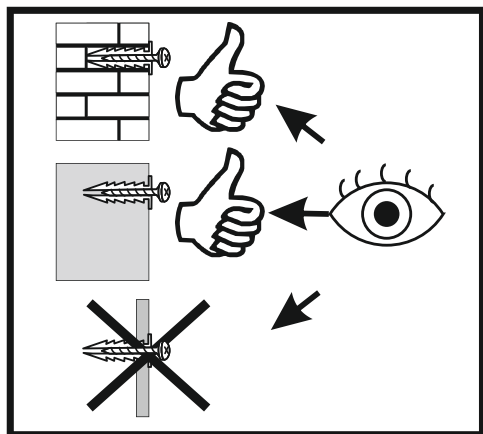

- Ⓡ Мебель должна крепиться к стене!
- Ⓙ Il mobile deve essere fissato alla parete!
- Ⓜ A bútor a falon rögzítendő!
- Ⓟ O móvel tem que ser fixado na parede!
- Ⓒ Nábytek musí být připevněn ke stěně!

- Ⓡ Перед тем, как крепить мебель к стене, получите информацию о подходящем крепежном материале!
- Ⓙ Prima del fissaggio alla parete, informarsi sul materiale di montaggio adatto!
- Ⓜ A falra szerelés előtt tájékozódjon, hogy ehhez milyen szerelőanyagok szükségesek!
- Ⓟ Antes da montagem na parede, informe-se sobre o material de montagem adequado!
- Ⓒ Informujte se o vhodném montážním materiálu před montáží na stěnu!

- Ⓡ Приобретите соответствующий материал для крепления к стене!
- Ⓙ Procurarsi il materiale opportuno per il fissaggio alla parete!
- Ⓜ Szerezze be a falra szereléshez szükséges, megfelelő anyagokat!
- Ⓟ Obtenha o material adequado para a montagem na parede!
- Ⓒ Opatřte si vhodný materiál pro montáž na stěnu!

- Ⓡ Поручите выполнение работ по креплению к стене специалисту!
- Ⓙ Far effettuare il fissaggio alla parete ad un esperto!
- Ⓜ A bútor falra rögzítését végeztesse ehhez értő személlyel!
- Ⓟ A montagem na parede deve ser executada por uma pessoa competente!
- Ⓒ Montáž na stěnu nechte provést odborně způsobilou osobou!

