

The instructions shall be headed:
**IMPORTANT - READ CAREFULLY -
RETAIN FOR FUTURE REFERENCE**

ASSEMBLY INSTRUCTION 89540

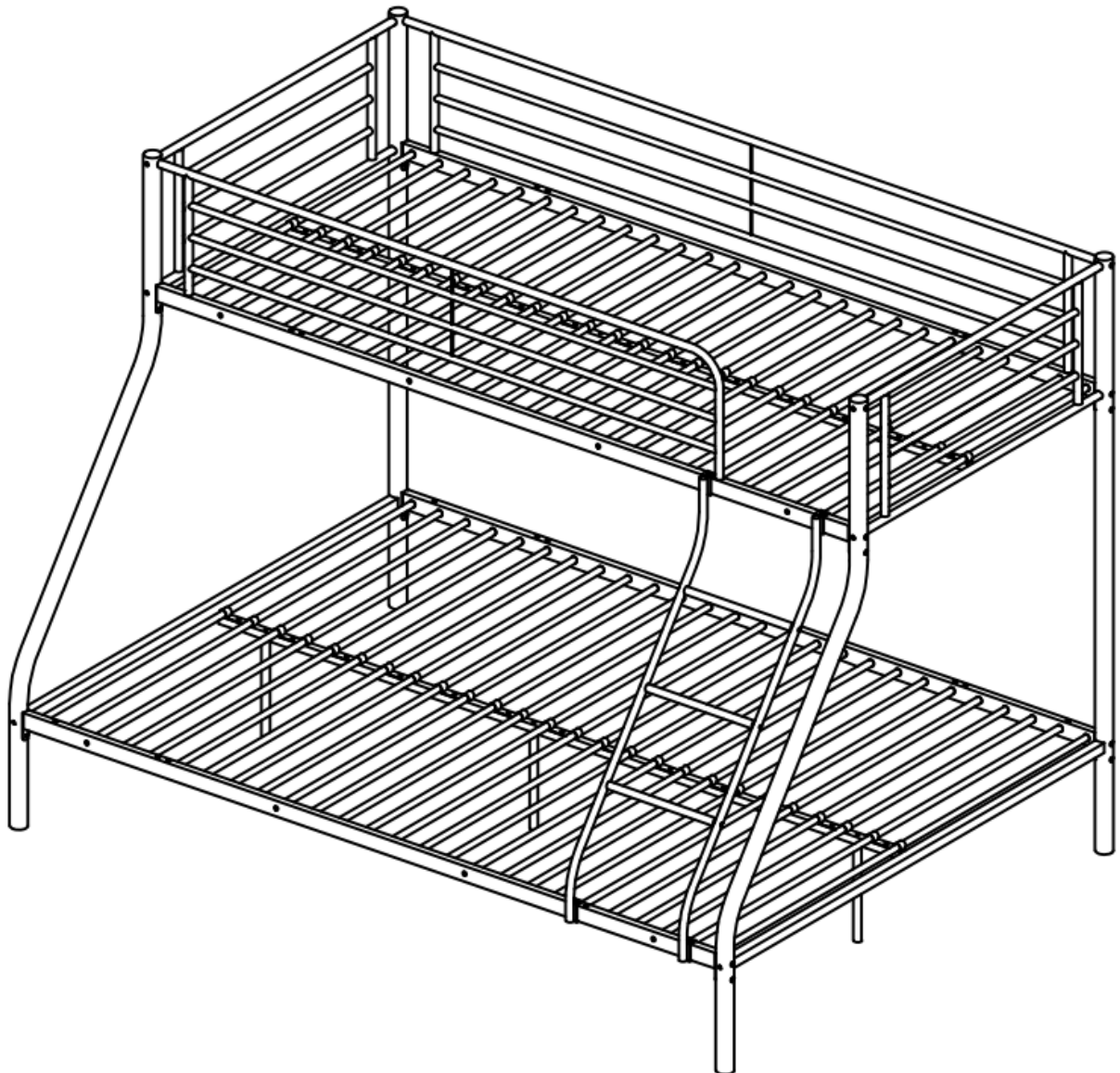

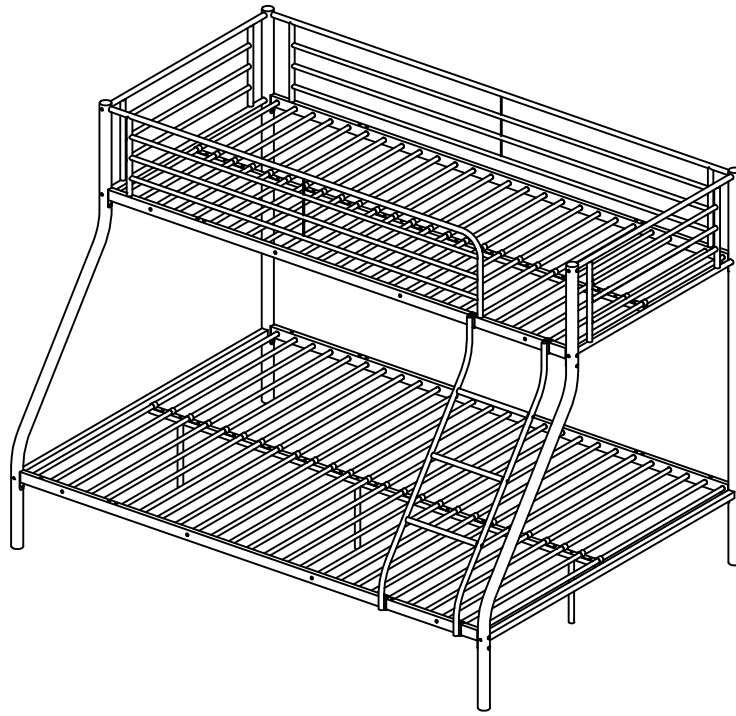

①-2pcs



②-2pcs

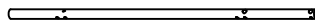

③-2pcs



④-2pcs

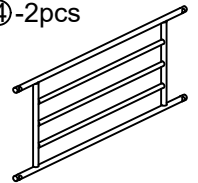

⑤-4pcs

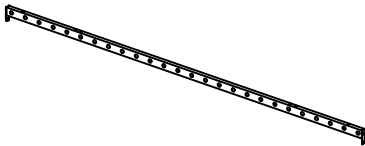

⑥-4pcs

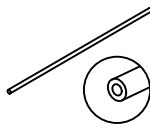

⑦-22pcs

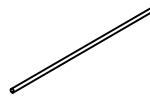

⑧-4pcs

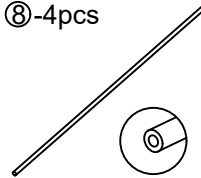

⑨-22pcs

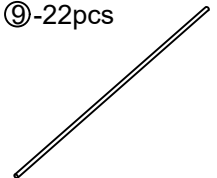

⑩-2pcs



⑪-1pc

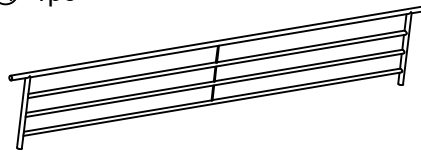

⑫-1pc

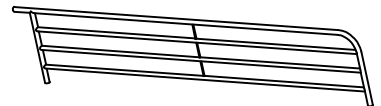

⑬-3pcs



⑭-2pcs

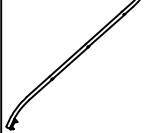

⑮-3pcs

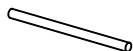

⑯-26pcs

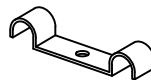

A-24pcs
M6x18



B-32pcs
M6x30



C-4pcs
M6x45



D-7pcs
M6x65



E-11pcs
M8x45



F-8pcs
M8x60

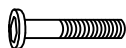

G-4pcs
M6x18



H-8pcs
M8x18



J-20pcs



K-4pcs



L-4pcs
Ø50



M-4pcs
Ø22



N-38pcs
Ø10



O-1pc
#4



P-2pcs
#5

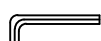

Q-1pc



R-4pcs
20x20



S-26pcs
M6



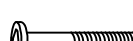

T-4pcs
M8x65

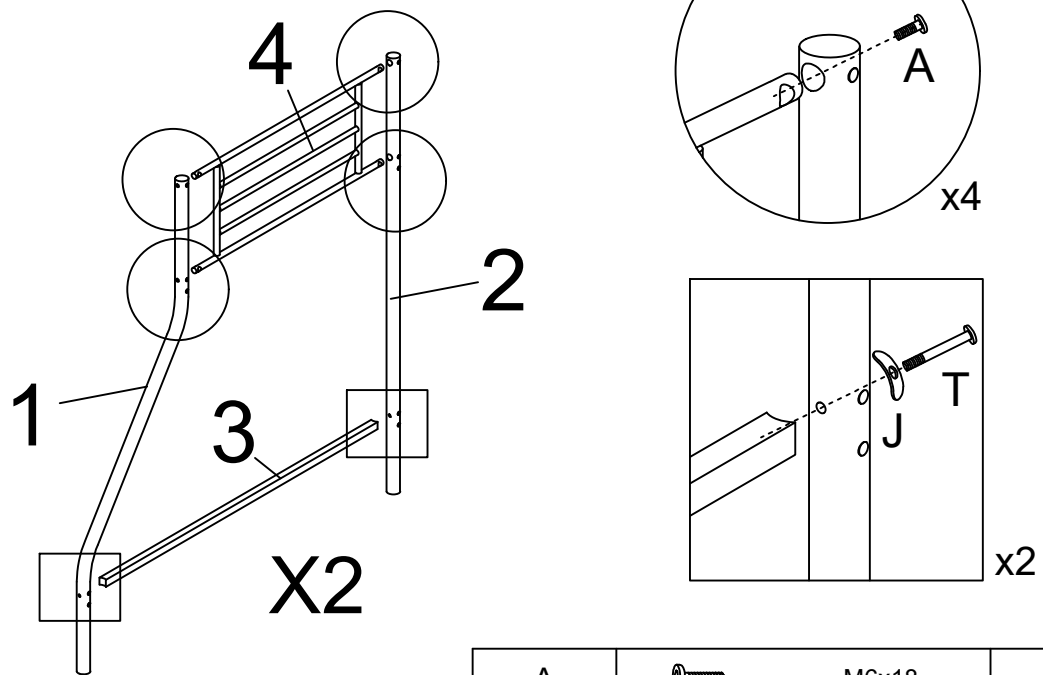

1

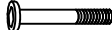

A		M6x18	8
J			4
T		M8x65	4

2

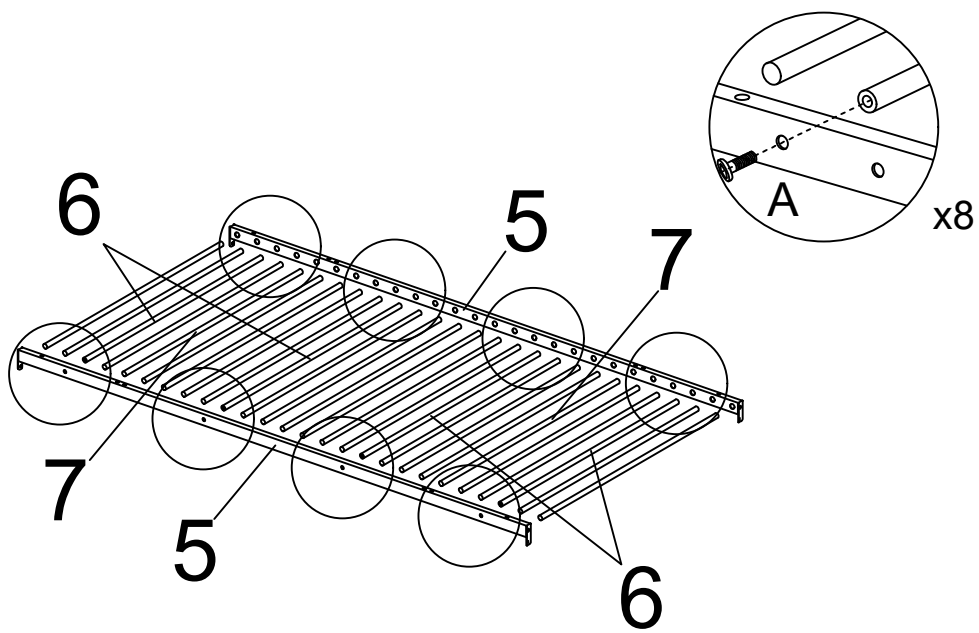

A		M6x18	8
---	---	-------	---

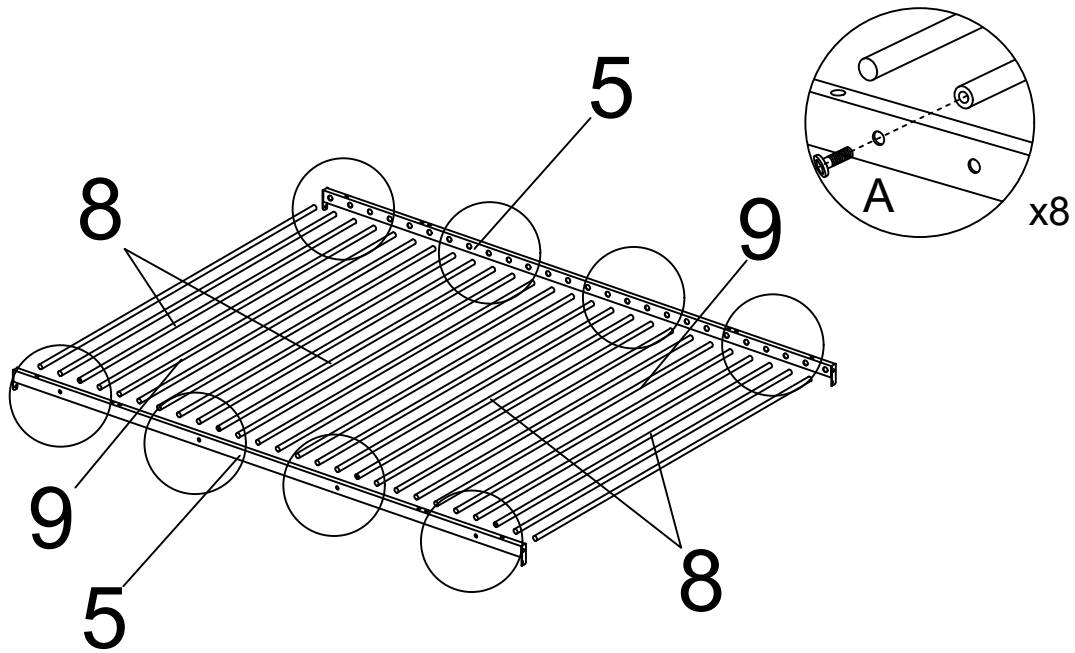

3



A		M6x18	8
---	---	-------	---

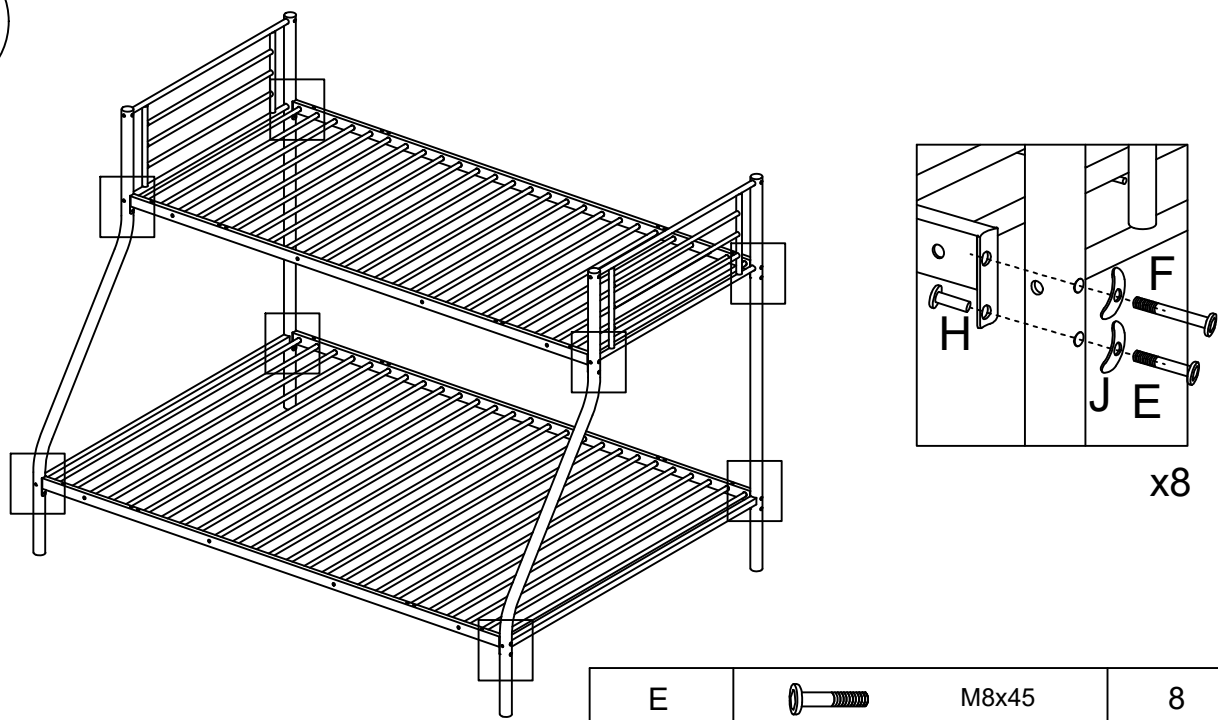

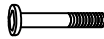
4



E		M8x45	8
F		M8x60	8
H		M8x18	8
J			16

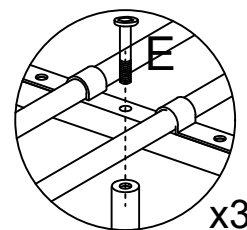
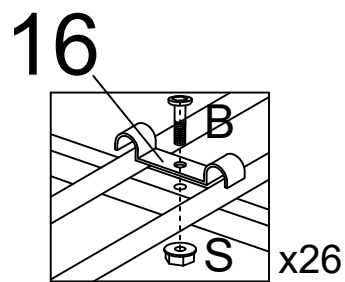
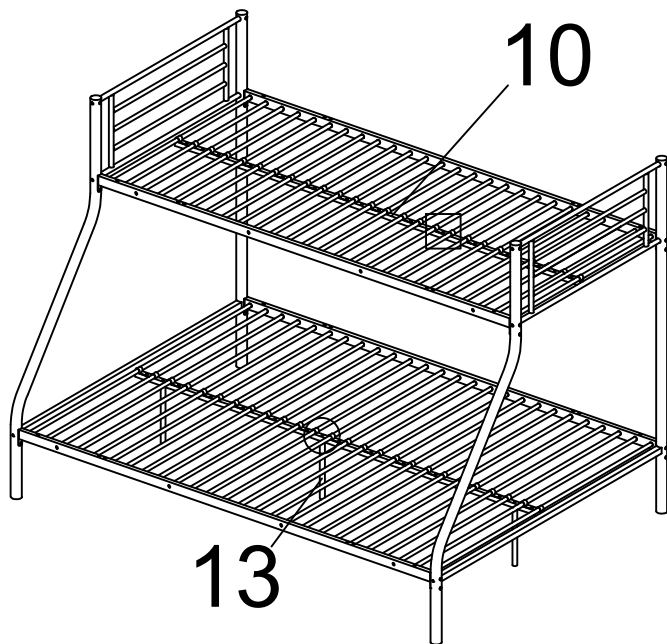

5

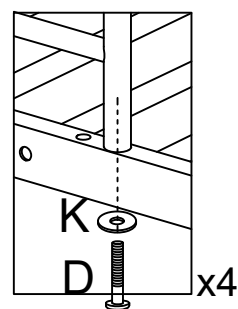
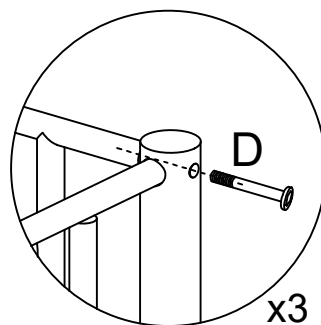
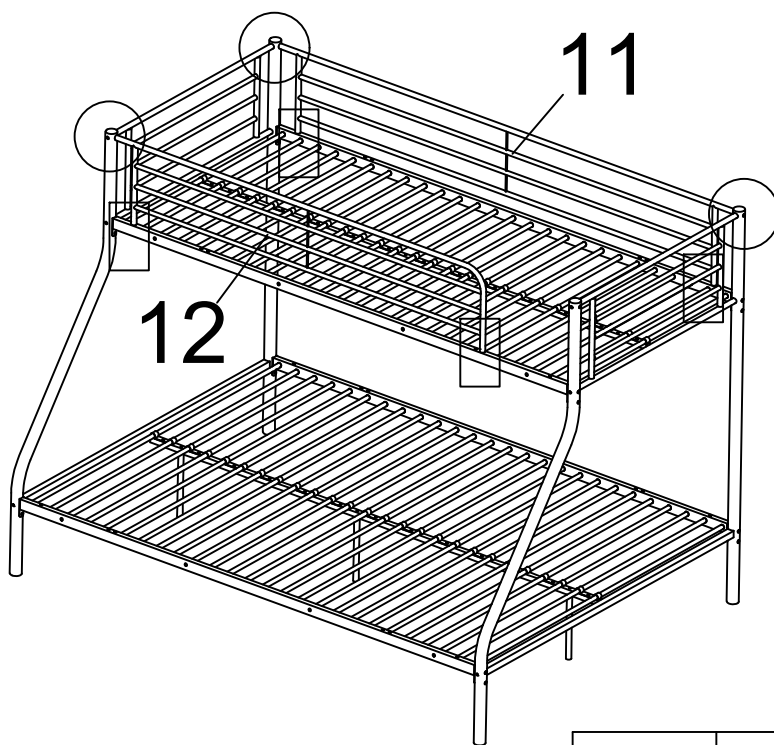

B		M6x30	26
E		M8x45	3
S		M6	26

6



D		M6x65	7
K			4



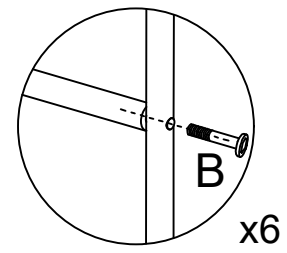
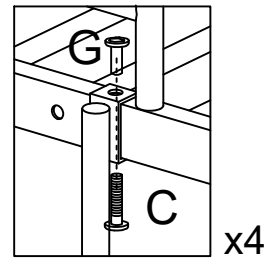
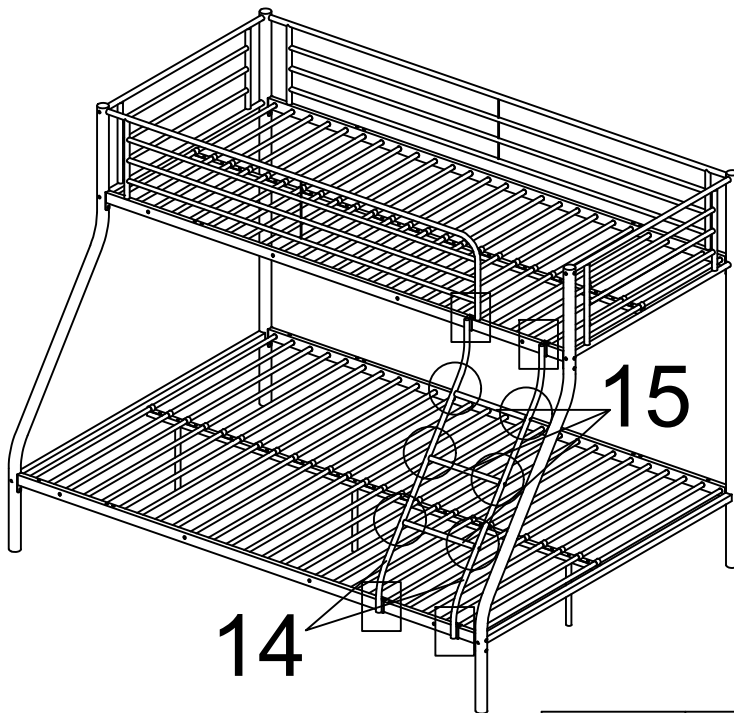

7

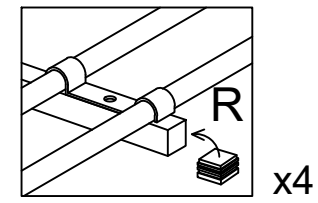
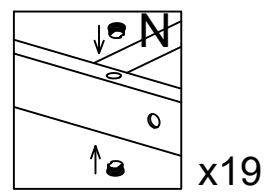
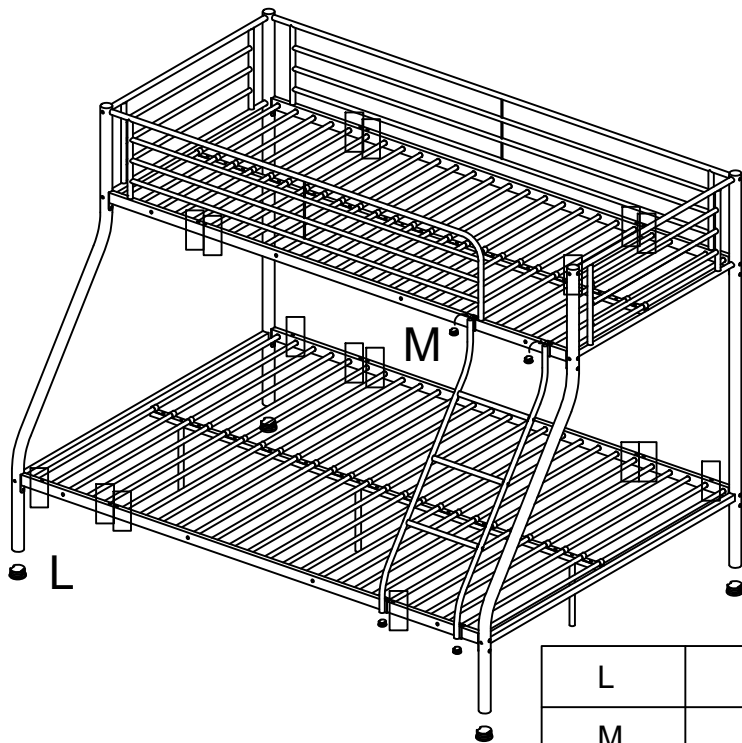

B		M6x30	6
C		M6x45	4
G		M6x18	4

8



L		Ø50	4
M		Ø22	4
N		Ø10	38
R		20x20	4

1 General warnings

Read all the instructions and warnings carefully before using this product. Failure to follow warnings and instructions can result in severe injury, death, or property damage. Before installation, check if all accessories are complete and without damage. If not, contact customer service. Keep these instructions in a safe place for future reference. Use this product with its original parts only. Rousseau cannot be held responsible in the event of damage or injury due to incorrect use of this product. The information contained in this manual is believed to be correct at the time of printing. However, Rousseau reserve the right to change or modify any of the specifications without notice or obligation to update existing units. Repairs should only be carried out by a specialist or a professional and experienced technician. Never attempt to repair the product yourself.

2 Warnings and personal safety

- Important - Read carefully - Keep for future reference.
- Warning: High beds and the upper bed of bunk beds are not suitable for children under six years due to the risk of injury from falls.
- Warning: Bunk beds and high beds can present a serious risk of injury from strangulation if not used correctly. Never attach or hang items to any part of the bunk bed that are not designed to be used with the bed, for example, but not limited to ropes, strings, cords, hooks, belts and bags.
- Warning: Children can become trapped between the bed and the wall, a roof pitch, the ceiling, adjoining pieces of furniture (e.g. cupboards) and the like. To avoid risk of serious injury the distance between the top safety barrier and the adjoining structure shall not exceed 75 mm or shall be more than 230 mm.
- Warning: Do not use the bunk bed/high bed if any structural part is broken or missing.
- It is essential that the manufacturer's instructions for assembly and use are followed.
- The recommended mattress size for this bed is 2000mm x 900 mm, with a maximum thickness of 175 mm.
- Mattresses must be aired to maintain a low humidity and to stop moisture building up in the bed and its surroundings.
- All fastenings on the bunk bed must be properly tightened and regularly checked. Retighten the fastenings if necessary.
- This product is in compliance with the European Safety Standard EN747-1,2:2012+A1:2015.
- The addition of a night light would greatly increase the safety of a child sleeping in the top bunk.
- Access the upper bed using the ladder only.

3 Avertissements généraux

Lire attentivement toutes les instructions et les avertissements avant d'utiliser ce produit. Le non-respect des avertissements et des instructions peut entraîner des blessures graves, la mort ou des dommages matériels. Avant l'installation, vérifier si tous les accessoires sont complets et sans dommage. Sinon, contacter le service à la clientèle. Garder ces instructions dans un endroit sûr pour une référence ultérieure. Utiliser ce produit uniquement avec ses pièces d'origine. Rousseau ne peut être tenu responsable en cas de dommages ou de blessures en raison de l'utilisation incorrecte de ce produit. Les informations contenues dans ce manuel sont jugées correctes au moment de l'impression. Cependant, Rousseau se réserve le droit de changer ou de modifier les spécifications sans

- s'ils ne sont pas utilisés correctement. Ne jamais attacher ni accrocher d'articles à une partie du lit superposé qui ne sont pas conçus pour être utilisés avec le lit, par exemple, mais sans s'y limiter, des cordes, des câbles, des crochets, des ceintures et des sacs.
- Avertissement : Les enfants peuvent être piégés entre le lit et le mur, un toit, le plafond, des meubles adjacents (p. ex. des placards) et similaires. Afin d'éviter tout risque de blessures graves, la distance entre la barrière de sécurité supérieure et la structure adjacente ne doit pas dépasser 75 mm ou doit être supérieure à 230 mm.
 - Avertissement : Ne pas utiliser le lit superposé / le lit haut si une partie structurelle est cassée ou manquante.
 - Il est essentiel que les instructions du fabricant concernant l'assemblage et l'utilisation soient suivies.

préavis ni obligation de mettre à jour les unités existantes.
Les réparations ne doivent être effectuées que par un spécialiste ou un technicien professionnel et expérimenté.
Ne jamais essayer de réparer le produit vous-même.

2 Avertissements et sécurité personnelle

- Important - Lire attentivement - Conserver pour référence ultérieure.
- Avertissement : les lits hauts et le lit supérieur de lits superposés ne sont pas adaptés aux enfants de moins de six ans en raison du risque de blessures causées par les chutes.
- Avertissement : les lits superposés et les lits hauts peuvent présenter un risque sérieux de blessures par strangulation

- La taille de matelas recommandée pour ce lit est de 2000mm x 900 mm, avec une épaisseur maximale de 175 mm.
- Les matelas doivent être ventilés pour maintenir une faible humidité et pour empêcher l'accumulation d'humidité dans le lit et ses environs.
- Toutes les attaches sur le lit superposé doivent être correctement serrées et vérifiées régulièrement. Resserrer les attaches si nécessaire.
- Ce produit est conforme à la norme européenne de sécurité EN747-1,2:2012+A1:2015.
- L'ajout d'une lumière de nuit augmentera considérablement la sécurité d'un enfant dormant dans le lit supérieur.
- Monter au lit supérieur en utilisant uniquement l'échelle.

NL Gebruikershandleiding

1 Algemene waarschuwingen

Lees alle instructies en waarschuwingen zorgvuldig door voordat u dit product gebruikt. Het niet opvolgen van waarschuwingen en instructies kan leiden tot ernstig letsel, overlijden of materiële schade. Controleer vóór de installatie of alle accessoires compleet zijn en niet beschadigd zijn. Zo niet,

een van de specificaties te wijzigen zonder voorafgaande kennisgeving of verplichting om bestaande eenheden te updaten. Reparaties mogen alleen uitgevoerd worden door een specialist of een professionele en ervaren technicus. Probeer het product nooit zelf te repareren.

neem dan contact op met de klantenservice. Bewaar deze instructies op een veilige plaats voor toekomstige verwijzing. Gebruik dit product alleen met originele onderdelen. Rousseau kan niet aansprakelijk worden gesteld bij schade of letsel door onjuist gebruik van dit product. De informatie die in deze handleiding is opgenomen wordt geacht correct te zijn op het moment van afdrucken. Rousseau behoudt echter het recht om

2 Waarschuwingen en persoonlijke veiligheid

- Belangrijk - Lees zorgvuldig - Bewaar voor toekomstige referentie.
- Waarschuwing: hoge bedden en de bovenste bedden van stapelbedden zijn niet geschikt voor kinderen jonger dan zes, vanwege het risico op letsel door vallen.
- Waarschuwing: stapelbedden en hoge bedden kunnen een aanzienlijk risico op verstikking zijn als ze niet correct worden gebruikt. Bevestig of hang nooit objecten aan het stapelbed die hier niet voor ontworpen zijn, zoals: touwen, koorden, haken, riemen en tassen.
- Waarschuwing: kinderen kunnen vast komen te zitten tussen het bed en de muur, een dakhelling, het plafond, aansluitende meubelen (bijv. kastjes) enzovoorts. Om het risico op ernstig letsel te vermijden mag de afstand tussen

de uiterste veiligheidsbarrière en het aansluitende meubelstuk niet minder zijn dan 75 mm en zal niet 230 mm overschrijden.

- Waarschuwing: gebruik het stapelbed/hoge bed niet als enig structureel onderdeel mist of gebroken is.
- Het is essentieel dat de fabrieksinstructies voor montage worden gebruikt en gevolgd.
- De aanbevolen matrasafmeting voor dit bed is 2000mm x 900 mm, met een maximale dikte van 175 mm.
- Matrassen moeten gelucht worden om een laag vochtigheidsgehalte te behouden en vochttopbouw in het bed en de omgeving te voorkomen.
- Alle bevestigingen op het stapelbed moeten naar behoren vastgedraaid worden en regelmatig worden gecontroleerd. Draai de bevestigingen opnieuw aan, indien nodig.
- Dit product voldoet aan de Europese Veiligheidsstandaard EN747-1,2: 2012+A1:2015.
- De toevoeging van een nachtlampje zou de veiligheid van een kind in het bovenste bed van een stapelbed aanzienlijk vergroten.
- Gebruik alleen de ladder om toegang te krijgen tot het bovenste bed.