

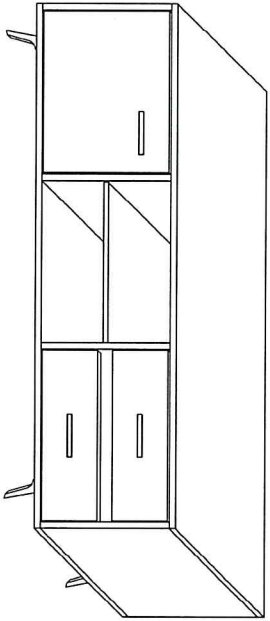

"SYSTEM WIVA" Meuble TV" WID-2"



NOTICE DE MONTAGE A CONSULTER AVANT TOUTE OPERATION D'ASSEMBLAGE
 Merci de vérifier la bonne conformité des pièces ainsi que la quantité.
 En cas d'éléments manquants ou endommagés, veuillez nous contacter le plus rapidement possible.

L'opération d'assemblage est à effectuer sur une surface propre et sec (couverture). Les dommages causés par un montage incorrect et le non-respect de la séquence d'assemblage ne peut faire l'objet de contestation.

Dans le cas où l'une des chevilles en bois qui sortait du trou sur une longueur supérieure à 10 mm ne devrait pas être utilisée, elle peut causer des dommages aux meubles en passant au travers.
 Ce cas ne peut ne peut être soumis à une contestation.

DON'T PUSH!

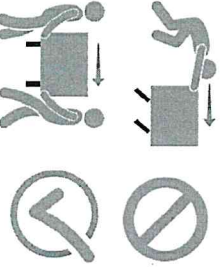

Eléments contenus dans le paquet

Eléments d'assemblage		Quincaillerie			
H11	Fond arrière	2 sct.	KM	Cheville en bois	28 sct.
B1L	Panneau montant gauche	1 sct.	KF	Ctø montage	1 sct.
B1P	Panneau montant gauche	1 sct.	M15	Excentrique	24 sct.
BL1G	Plaque supérieur	1 sct.	ZM	Grillon	24 sct.
BL1D	Soie inférieur	1 sct.	ZMU	Capechou	24 sct.
PR11	Panneau séparation	1 sct.	W3X20	Vs 3x20	4 sct.
PR12	Panneau séparation	1 sct.	W3X30	Vs 3x30	4 sct.
F11	Portes	1 sct.	PP	Taguet	4 sct.
P1	Blagère	1 sct.	W3,5X16	Vs 3,5x16	8 sct.
L1	Elément panneau	1 sct.	E63X13	Vs 6,3x13	4 sct.
F12	Facade tiroir	2 sct.	U-UR	Poligné U/R	3 sct.
ST1	Panneau arrière tiroir	2 sct.	W4X27P	Vs poligné 4x27	6 sct.
SBL	Côté gauche tiroir	2 sct.	PRD350	Grisière tiroir	2 sct.
SBP	Côté droit tiroir	2 sct.	E63X13ST	Vs couleur	8 sct.
H12	Fond tiroir	2 sct.	SP	Equerre	18 sct.
			Z0	Elément dernière	2 sct.
			PZ	Elément dernière	2 sct.
			NP45	Support en plastique	4 sct.
			E63X13	Vs pour NP45	12 sct.
			NR	Peton	1 sct.

NR



PRD350 PZ Z0 KM ZM

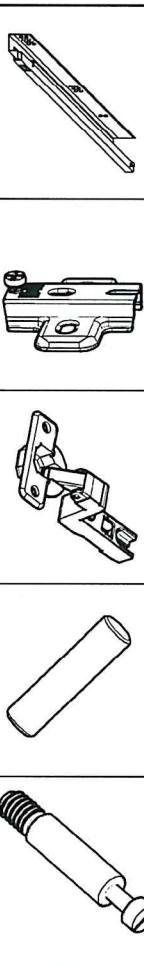

SP W4X35P W4X30PPP K70X50 M15

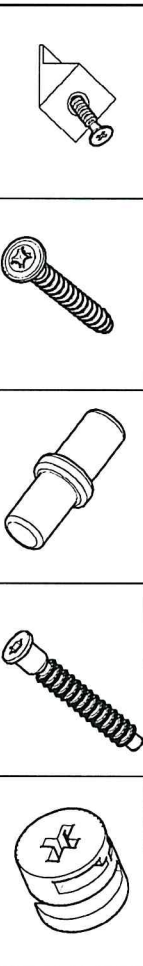

ZK ZMU U-UR KF NP45 W35X16 W3X30

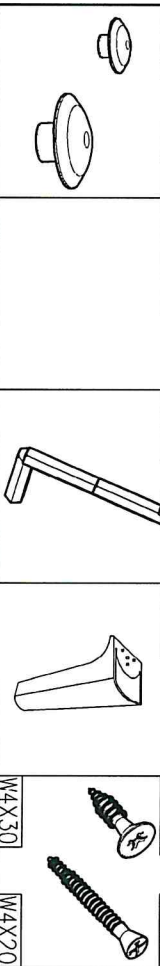

W4X30 W4X20

Outillage nécessaire

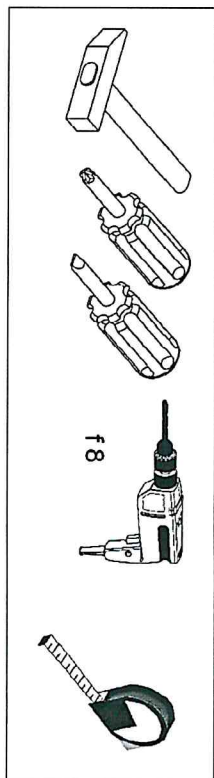

Principe d'assemblage pas goujon/excentrique

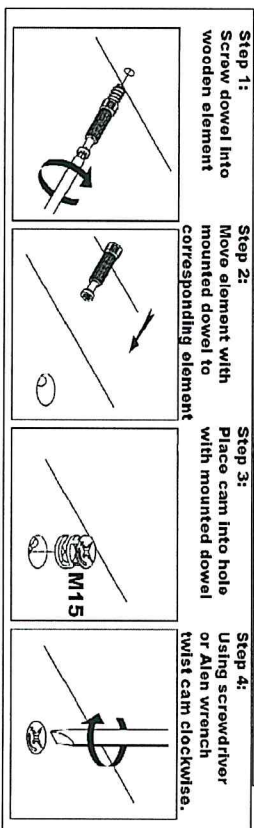

Instructions d'assemblage

Fig. 1-4.

Assemblage des éléments.

1

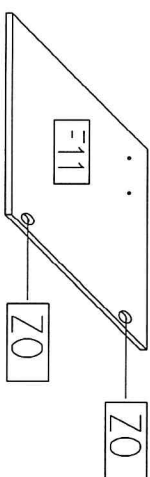
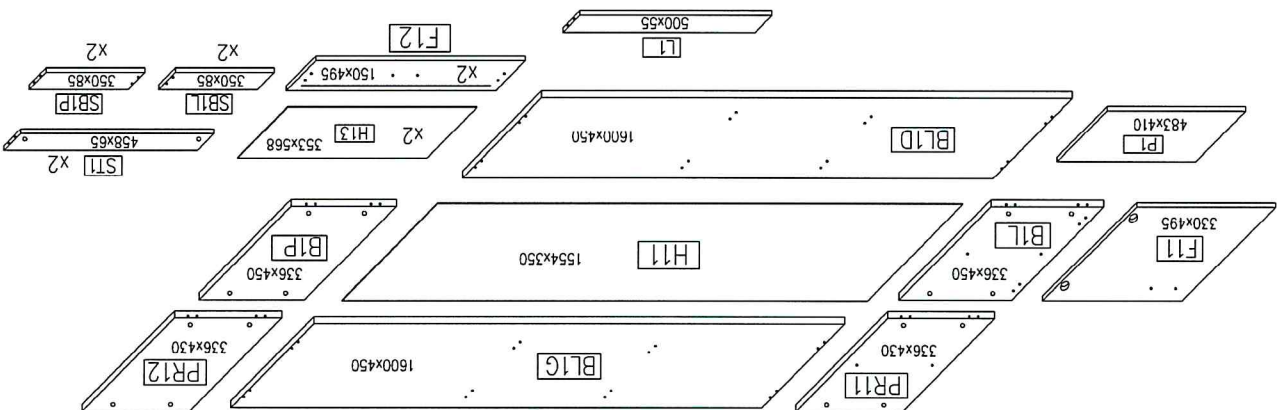
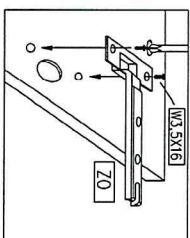
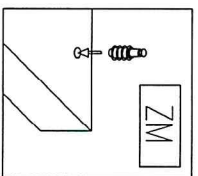
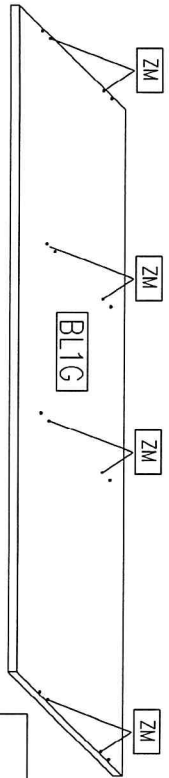
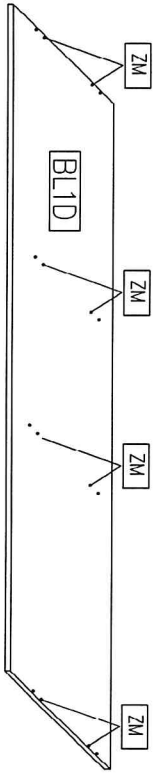
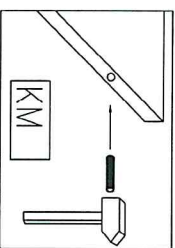
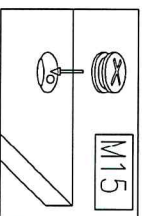
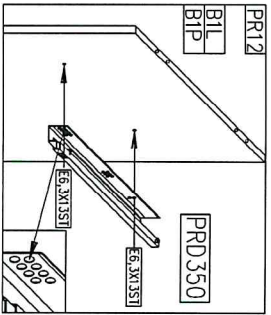
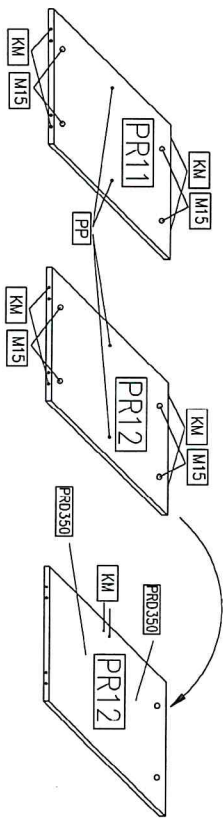
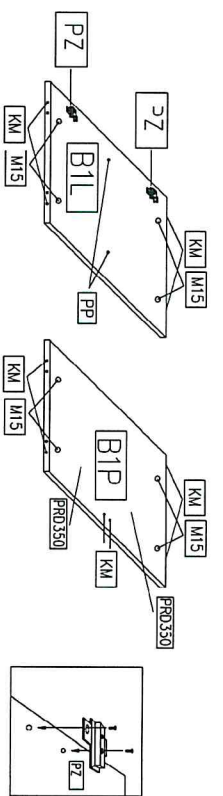

Fig. n°1

Montage des charnières sur les panneaux
vis. 35x16mm.



2



3

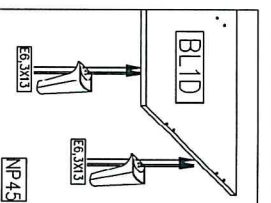
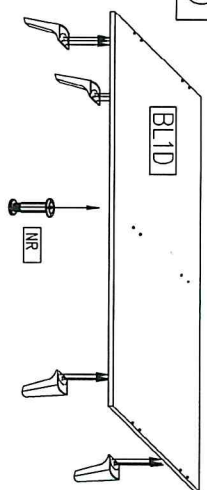

4

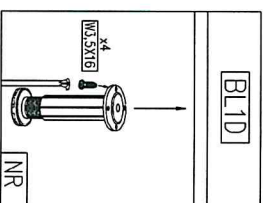
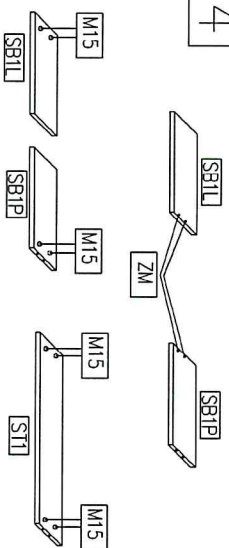

5

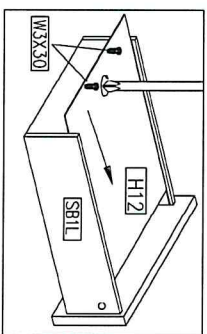
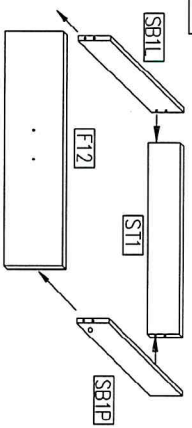

Assembler les éléments SB1L et SB1P avec le panneau arrière ST1.

Procéder ensuite à l'assemblage du fond H12 et les glissières PRD350.

6

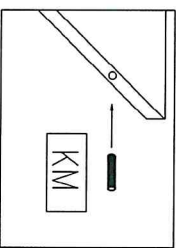
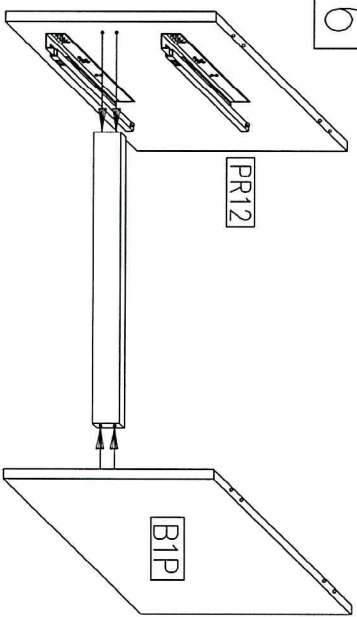
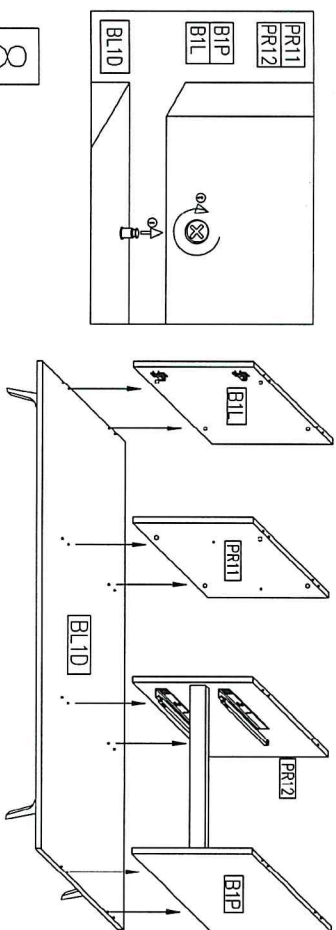
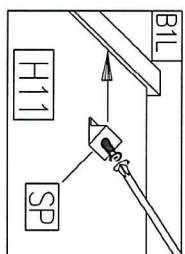

Fig. n°7

Placer les éléments sur le socle inférieur ainsi que le caisson de séparation.



8



Fixer le fond arrière dans les rainures avec les équerres cales (SP+W35X16).

$L1 = L2$ [cm]

9

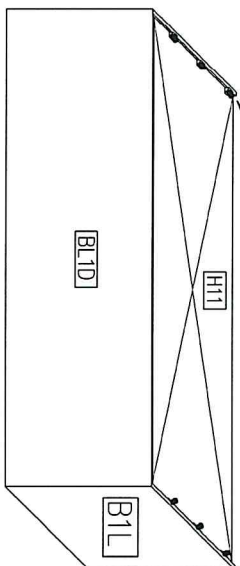

Fig. n°9
 Monter le plateau supérieur. Fixation par goujon/excentrique.

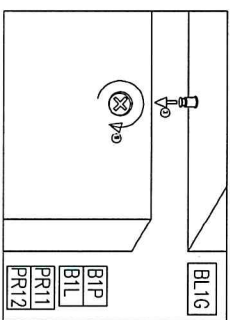
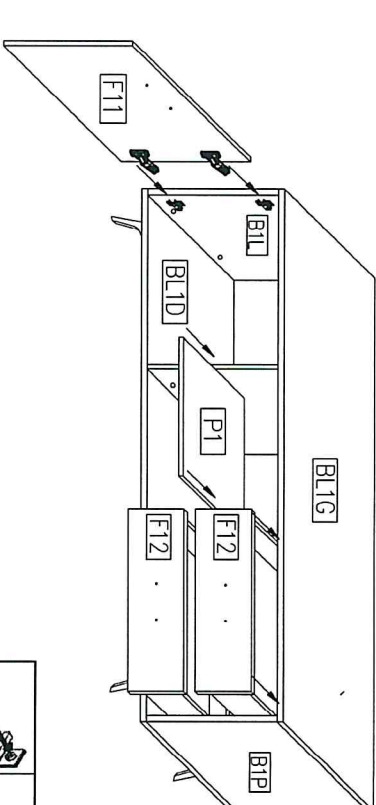

Fig. n°10

Monter ensuite les portes pour finaliser l'assemblage. Vérifier l'alignement et rectifier si besoin.



10

Placer les étagères et le tiroir.

