

DEN54/137

finori GmbH
Straßäcker 2
D - 96253 Untersiemau

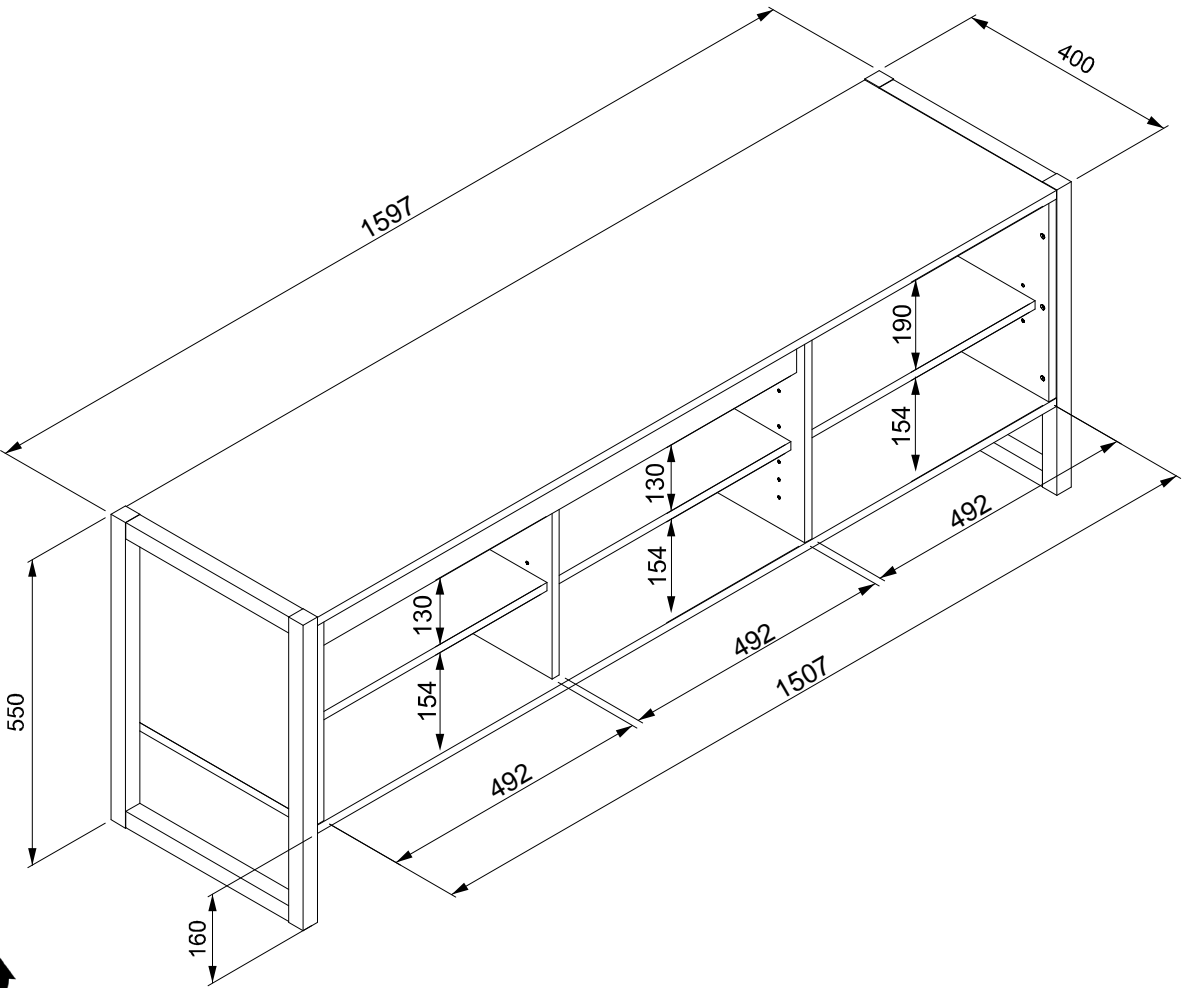

DEN54/137

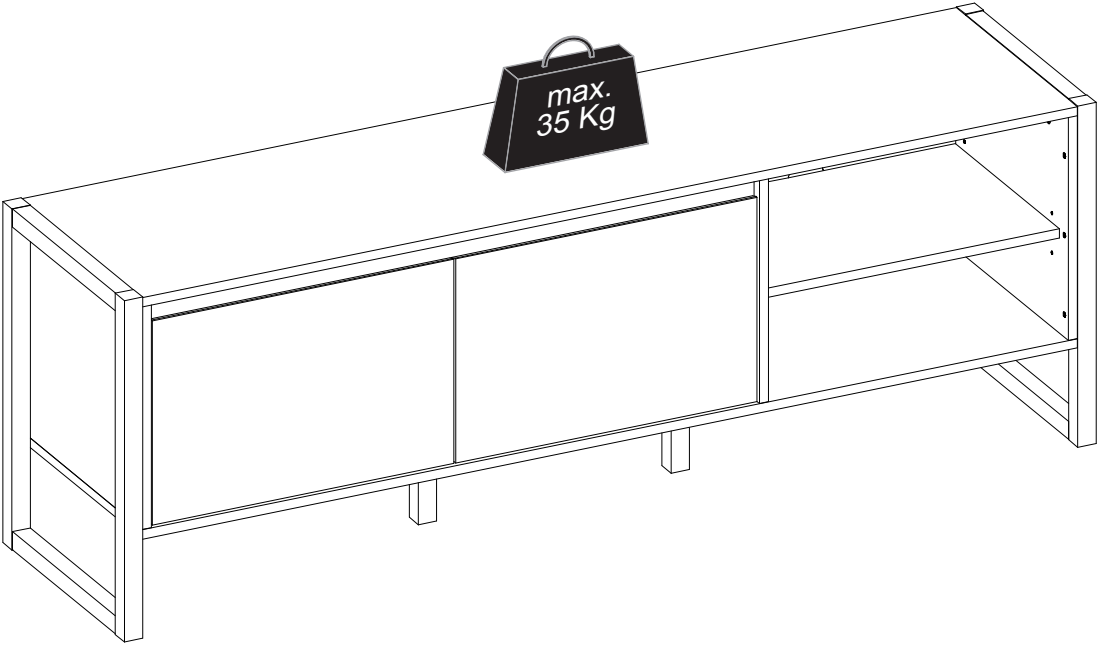
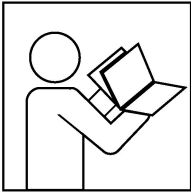

- ⓓ Befolgen Sie stets die Anleitung des Herstellers!
- ⒸⒷ Please generally follow the manufacturer's instructions!
- ⒻⓇ Suivez toujours les instructions du fabricant!
- ⓃⓁ Volg steeds de handleiding van de producent!
- ⒺⓈ Siga siempre las instrucciones del fabricante!
- ⓇⓁ Stale przestrzegaj instrukcji producenta!

- ⓇⓁ Всегда следуйте инструкции производителя!
- ⓇⓇ Seguire sempre le istruzioni del produttore!
- ⒻⓇ Mindig tartsa be a gyártó utasításait!
- Ⓡ Siga sempre as instruções do fabricante!
- ⒸⓏ Vždy dodržujte pokyny výrobce!



- ⓓ Verwenden Sie zur Reinigung nur ein feuchtes Tuch!
- ⒸⒷ Please only clean with a damp cloth!
- ⒻⓇ N'utilisez qu'un chiffon humide pour le nettoyage!
- ⓃⓁ Gebruik voor de reiniging enkel een vochtige doek!
- ⒺⓈ Para limpiar utilice sólo un paño húmedo!
- ⓇⓁ Do czyszczenia używaj wilgotnej szmatki!

- ⓇⓁ Для очистки используйте только влажную ткань!
- ⓇⓇ Per la pulizia, utilizzare solo un panno umido!
- ⒻⓇ A tisztításhoz elegendő egy nedves kendő használat!
- Ⓡ Para a limpeza use apenas um pano húmido!
- ⒸⓏ Pro čištění používejte pouze vlhký hadřík!

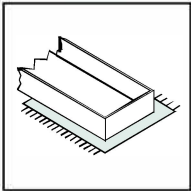

- ⓓ Bauen Sie das Produkt auf einer Unterlage auf!
- ⒸⒷ Please mount the product on a bottom support!
- ⒻⓇ Montez le produit sur une base!
- ⓃⓁ Monteer het product op een basis!
- ⒺⓈ Monte el producto sobre una base!
- ⓇⓁ Rozkładaj produkt na podkładce!

- ⓇⓁ Собирайте изделие на подстилке!
- ⓇⓇ Montare il prodotto su un supporto!
- ⒻⓇ Az összeszereléskor helyezzen a termék alá megfelelő alátétet!
- Ⓡ Monte o produto numa superfície plana!
- ⒸⓏ Výrobek smontujte na pevném podkladu!

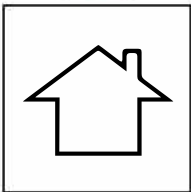

- ⓓ Verwenden Sie das Produkt nur in Innenräumen!
- ⒸⒷ Please exclusively use the product indoors!
- ⒻⓇ N'utilisez le produit qu'à l'intérieur!
- ⓃⓁ Gebruik het product enkel binnenshuis!
- ⒺⓈ Utilice el producto sólo en interiores!
- ⓇⓁ Używaj produkt tylko w pomieszczeniach wewnętrznych!

- ⓇⓁ Используйте изделие только во внутренних помещениях!
- ⓇⓇ Utilizzare il prodotto solo in ambienti interni!
- ⒻⓇ A termék csak bel terekben használható!
- Ⓡ Use o produto apenas no interior!
- ⒸⓏ Používejte výrobek pouze uvnitř!

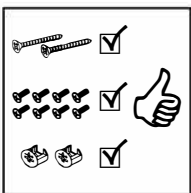

- ⓓ Legen Sie die Beschläge zusammen und prüfen Sie die Vollständigkeit!
- ⒸⒷ Please join the fittings and verify their completeness!
- ⒻⓇ Pliez les raccords ensemble et vérifiez qu'ils sont complets!
- ⓃⓁ Leg de onderdelen samen en controleer de volledigheid!
- ⒺⓈ Junte los accesorios y compruebe que están todos!
- ⓇⓁ Rozlož poszczególne części i sprawdź kompletność!

- ⓇⓁ Положите фурнитуру в одно место и проверьте комплектность!
- ⓇⓇ Mettere insieme le guarnizioni e verificarne la completezza!
- ⒻⓇ Állítsa össze a sarokvasakat, és ellenőrizze, hogy épek-e!
- Ⓡ Coloque os encaixes juntos e verifique se estão completos!
- ⒸⓏ Složte armatury a zkontrolujte úplnost!



- ⓓ Bei fehlenden Teilen kontaktieren Sie den Hersteller!
- ⒸⒷ If parts are missing, please turn to the manufacturer!
- ⒻⓇ En cas de pièces manquantes, veuillez contacter le fabricant!
- ⓃⓁ Contacteer de fabrikant als er onderdelen ontbreken!
- ⒺⓈ En el caso de que falten piezas, póngase en contacto con el fabricante!
- ⓇⓁ W razie braku części skontaktuj się z producentem!

- ⓇⓁ При отсутствии каких-либо частей обратитесь к производителю!
- ⓇⓇ In caso di pezzi mancanti, contattare il produttore!
- ⒻⓇ Ha hiányozna valamelyik elem, lépjen kapcsolatba a gyártóval!
- Ⓡ Em caso de peças em falta, entre em contato com o fabricante!
- ⒸⓏ Pro chybějící díly kontaktujte výrobce!



- ⓓ Ziehen Sie die Schrauben nach einiger Zeit des Gebrauchs erneut fest!
- ⒸⒷ Please re-tighten the screws after having used the product for a while!
- ⒻⓇ Resserrer les vis après un certain temps d'utilisation!
- ⓃⓁ Draai de schroeven na een zekere gebruikstijd opnieuw vast!
- ⒺⓈ Asegure de nuevo los tornillos tras usarlo durante un tiempo!
- ⓇⓁ Po pewnym czasie użytkowania ponownie dokręć śruby!

- ⓇⓁ Спустя некоторое время использования подкрутите гайки!
- ⓇⓇ Stringere nuovamente le viti dopo un certo periodo di utilizzo!
- ⒻⓇ A használat során némi idő elteltével húzza meg újra a csavarokat!
- Ⓡ Reaperte os parafusos após algum tempo de uso!
- ⒸⓏ Po určité době používání šrouby znovu utáhněte!

DEN54/137

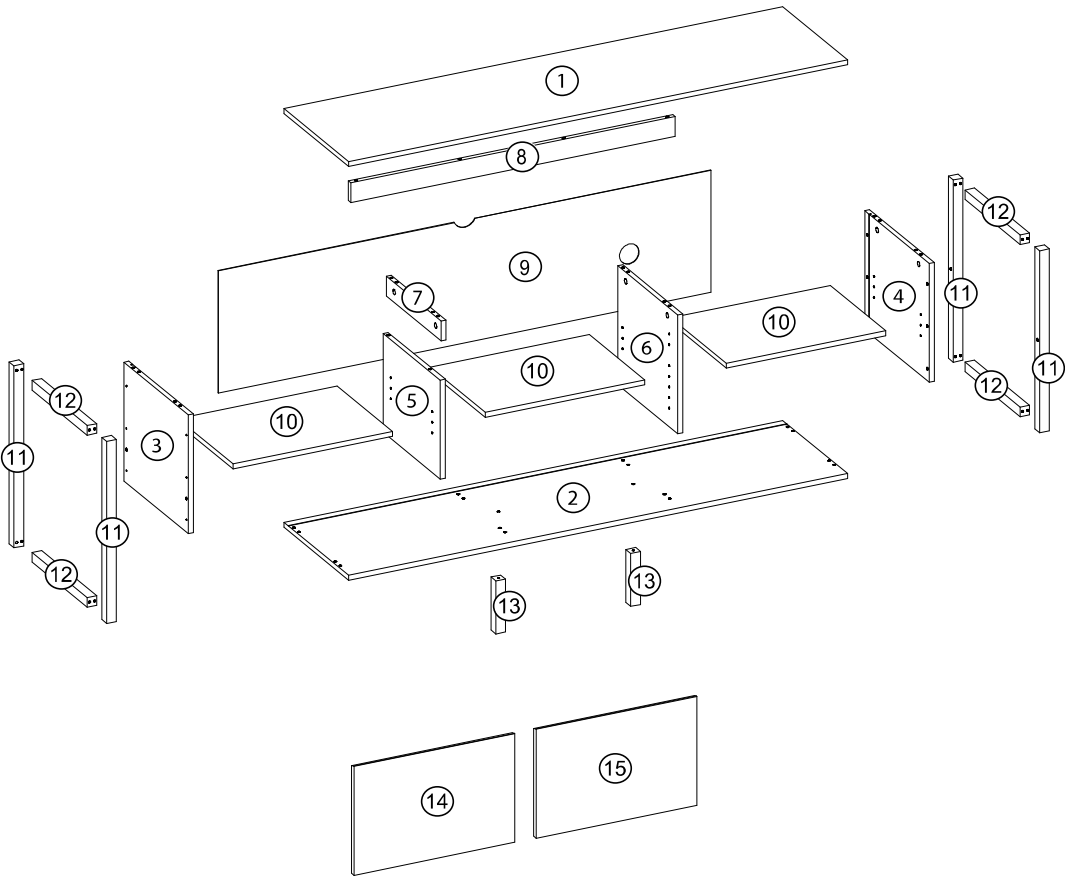
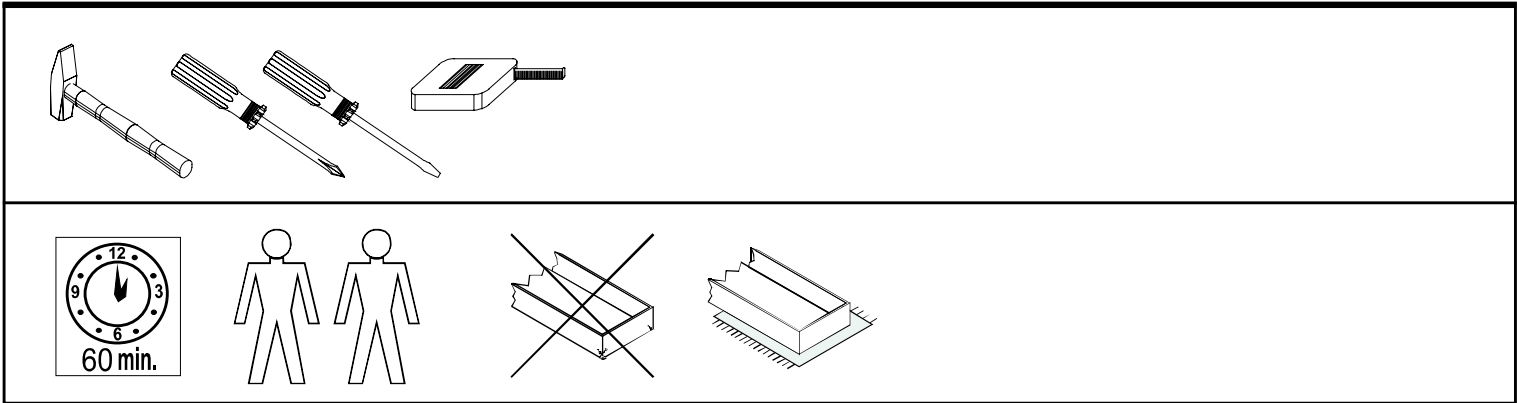

Dimensions / Abmessung in mm/		
①	1 x	1537 x 399 x 15
②	1 x	1537 x 399 x 15
③	1 x	359 x 398 x 15
④	1 x	359 x 398 x 15
⑤	1 x	299 x 352 x 15
⑥	1 x	359 x 370 x 15
⑦	1 x	338 x 60 x 15
⑧	1 x	1000 x 60 x 15
⑨	1 x	1517 x 369 x 2,5
⑩	3 x	491 x 342 x 15
⑪	4 x	550 x 30 x 30
⑫	4 x	340 29 x 29
⑬	2 x	160 x 30 x 30
⑭	1 x	329 x 495 x 15
⑮	1 x	329 x 495 x 15

BOX 1	1, 2, 3, 4, 5, 6, 7, 8, 9, 10, 11, 12, 13, 14, 15
--------------	---

DEN54/137



BOX 1

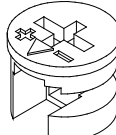
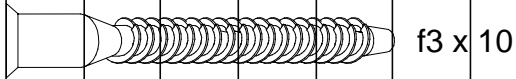

a1 x 8

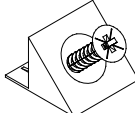

m1 x 8



o4 x 2



o10 x 6

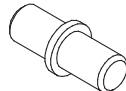
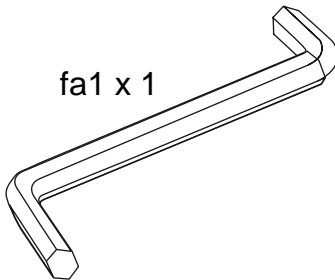

n1 x 12



o1 x 5



c2 x 8

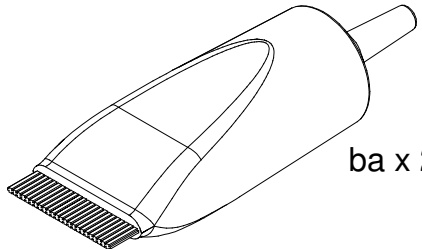

r55x 2

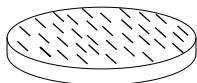
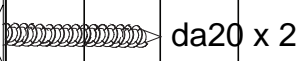
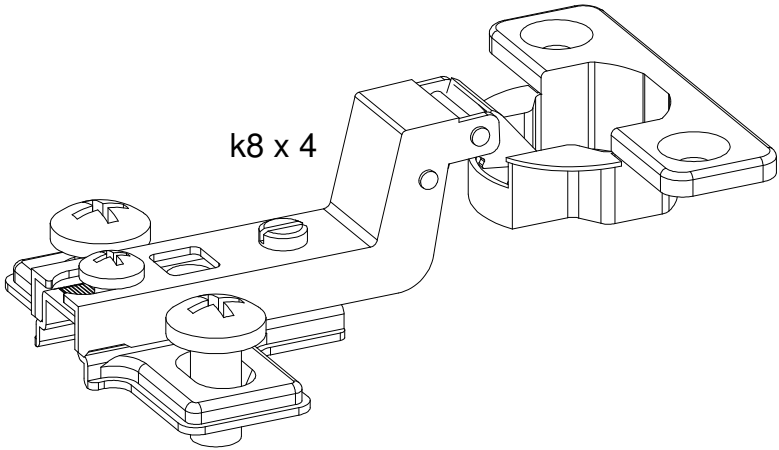
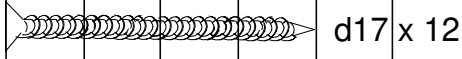

p33 x 6

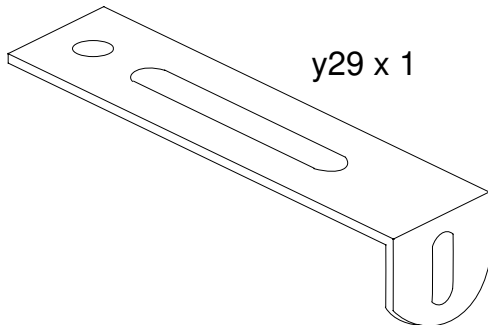

DEN54/137

A

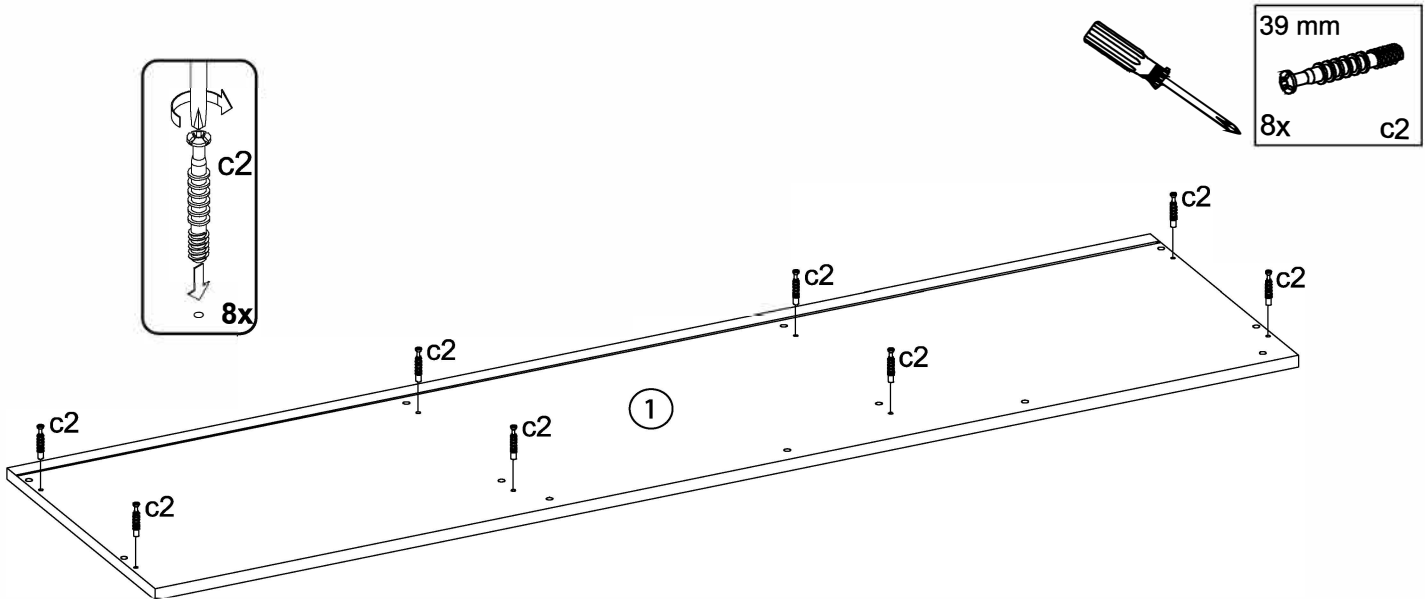

B

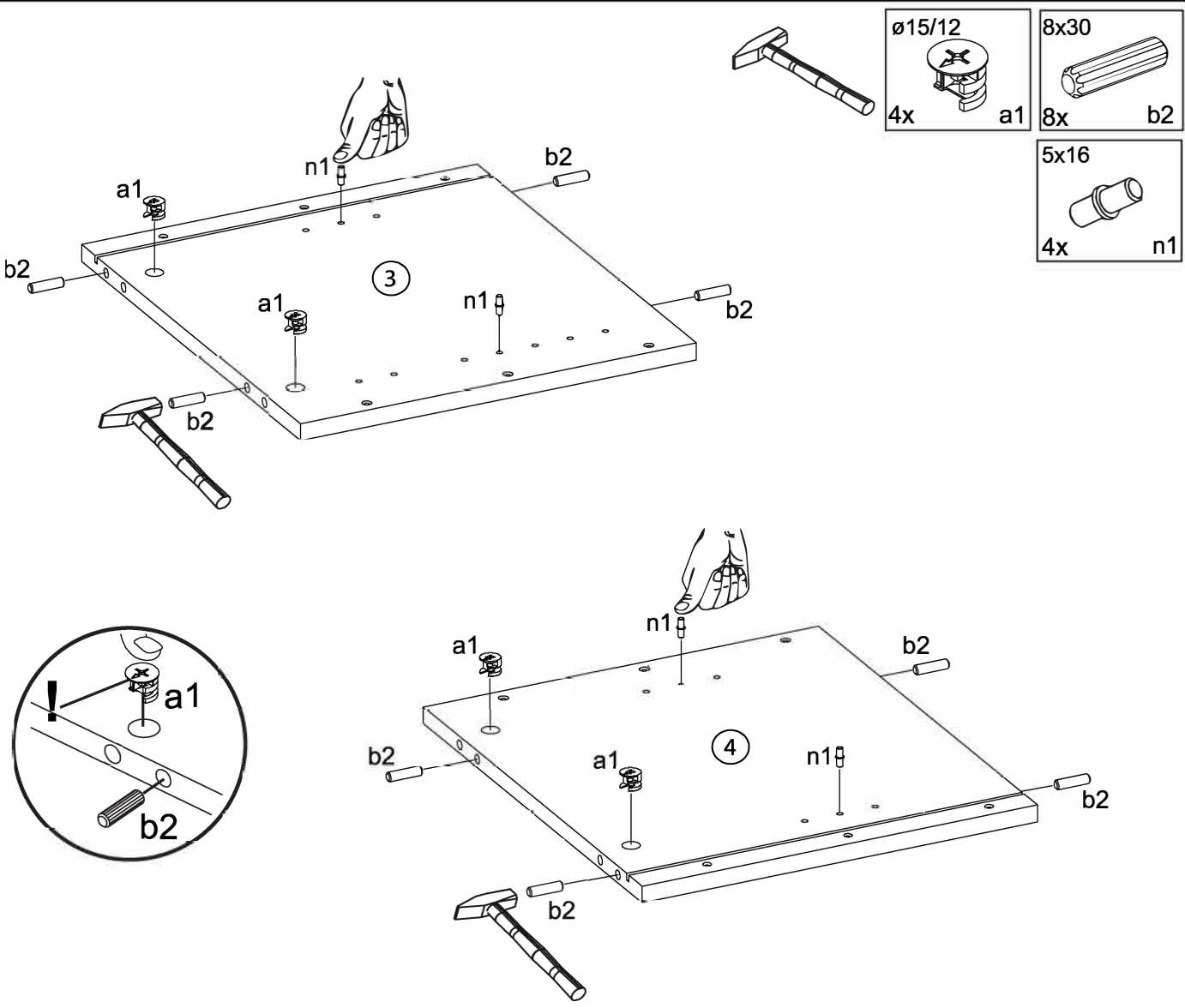

DEN54/137

C

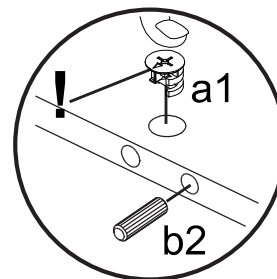
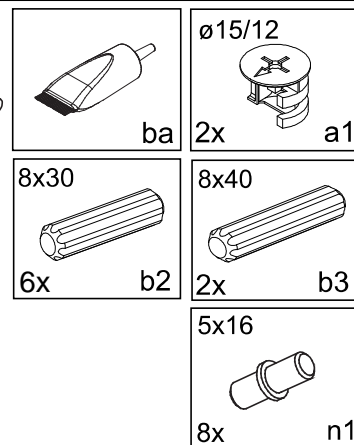
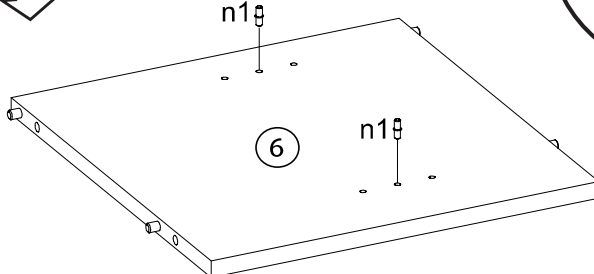
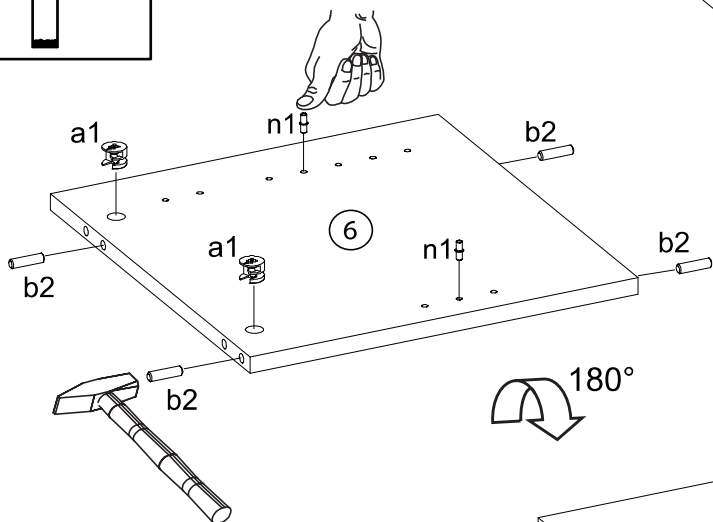
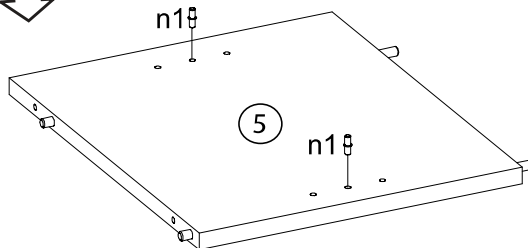
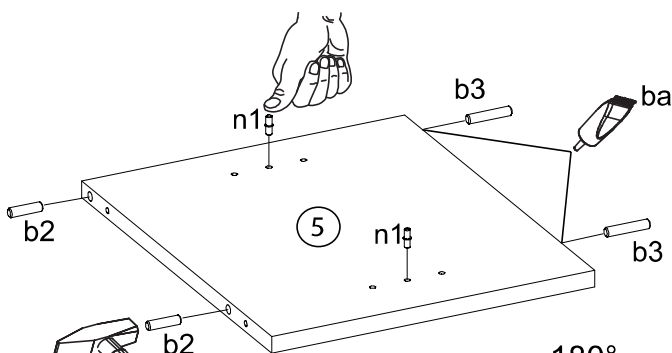
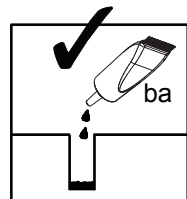
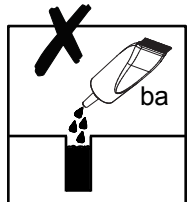

D

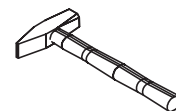
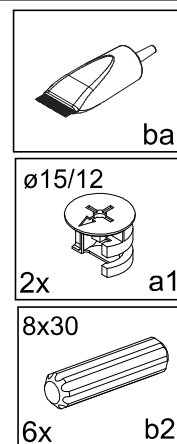
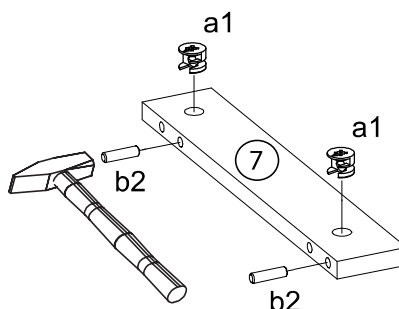
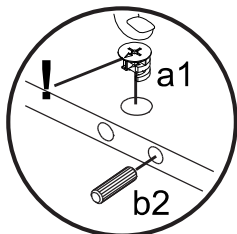
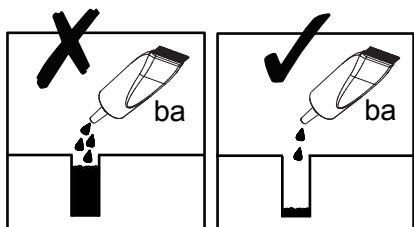
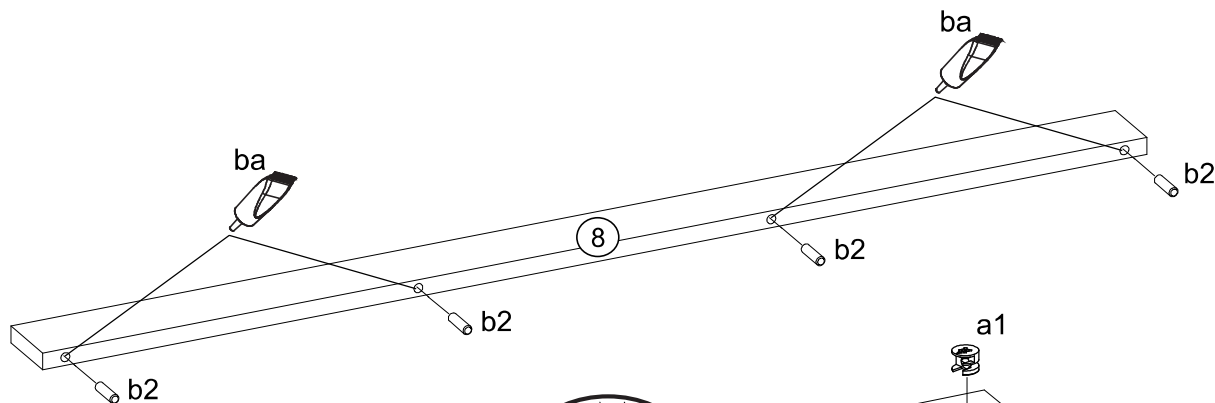

DEN54/137

G

3,5x15

∅35

8x d11

4x k8

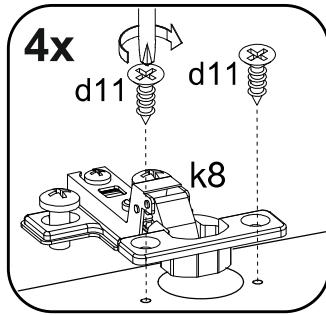
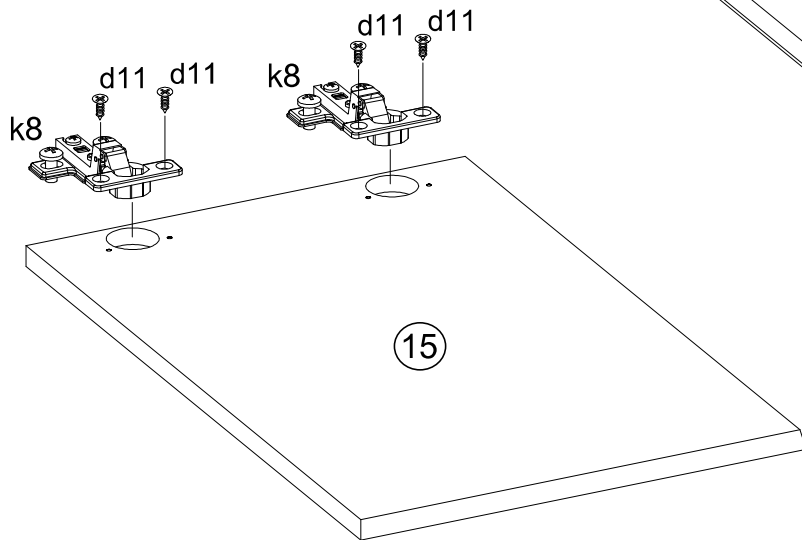
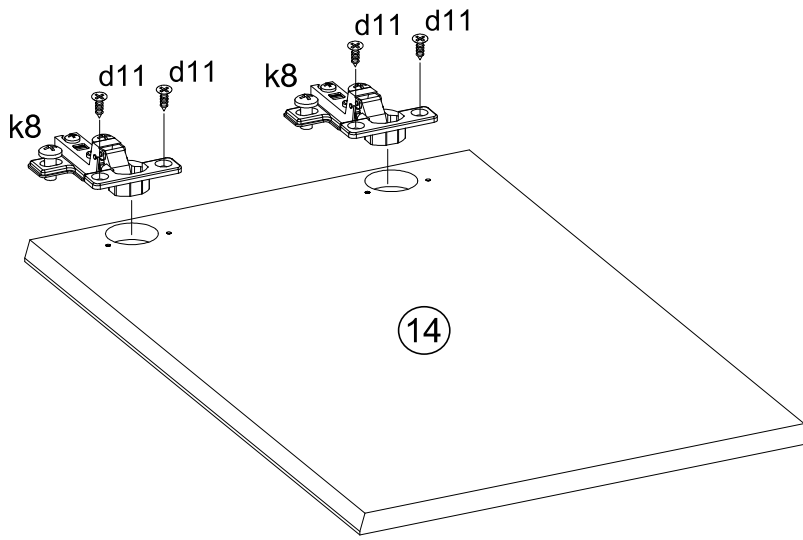

H

ba

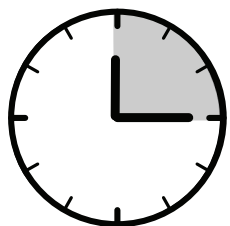
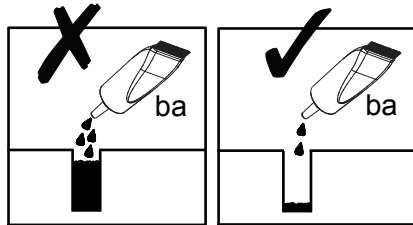
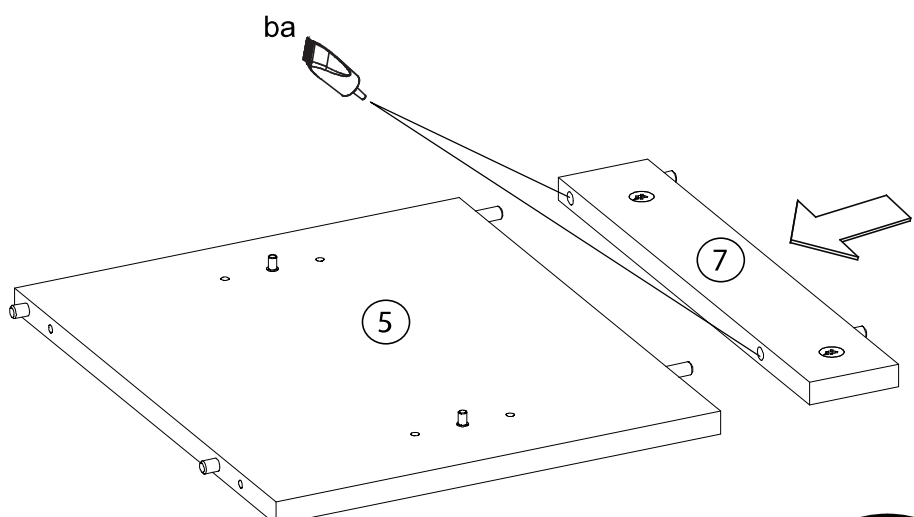
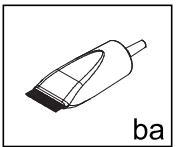

DEN54/137

I

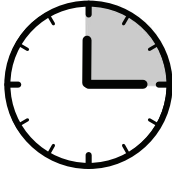
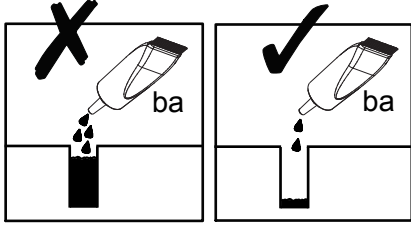
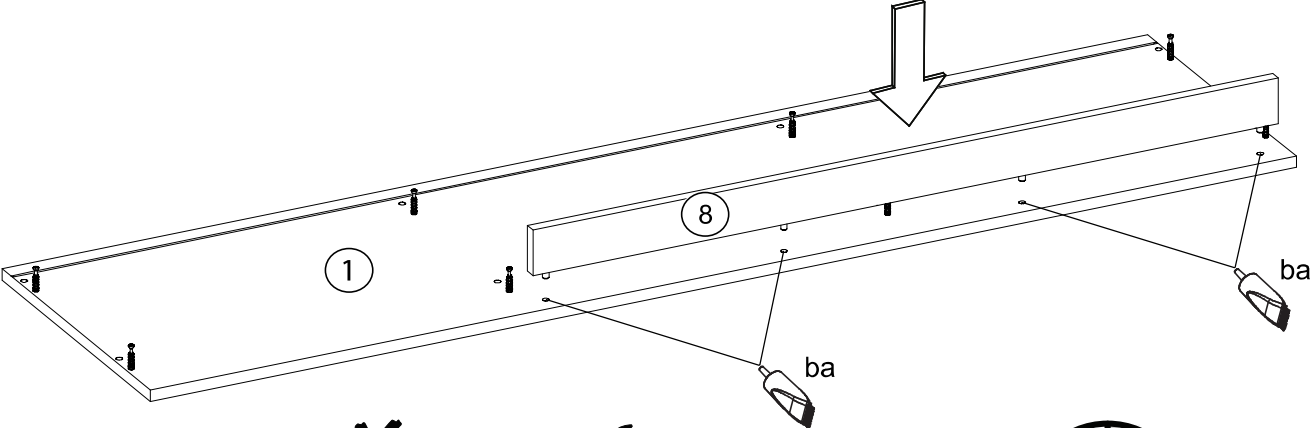
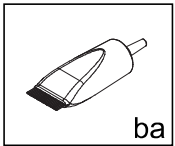

J

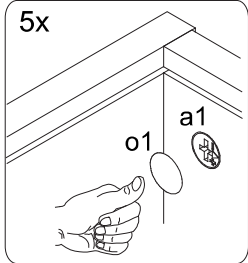
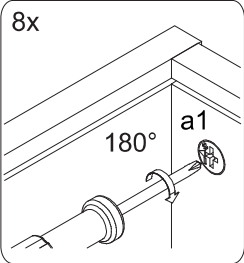
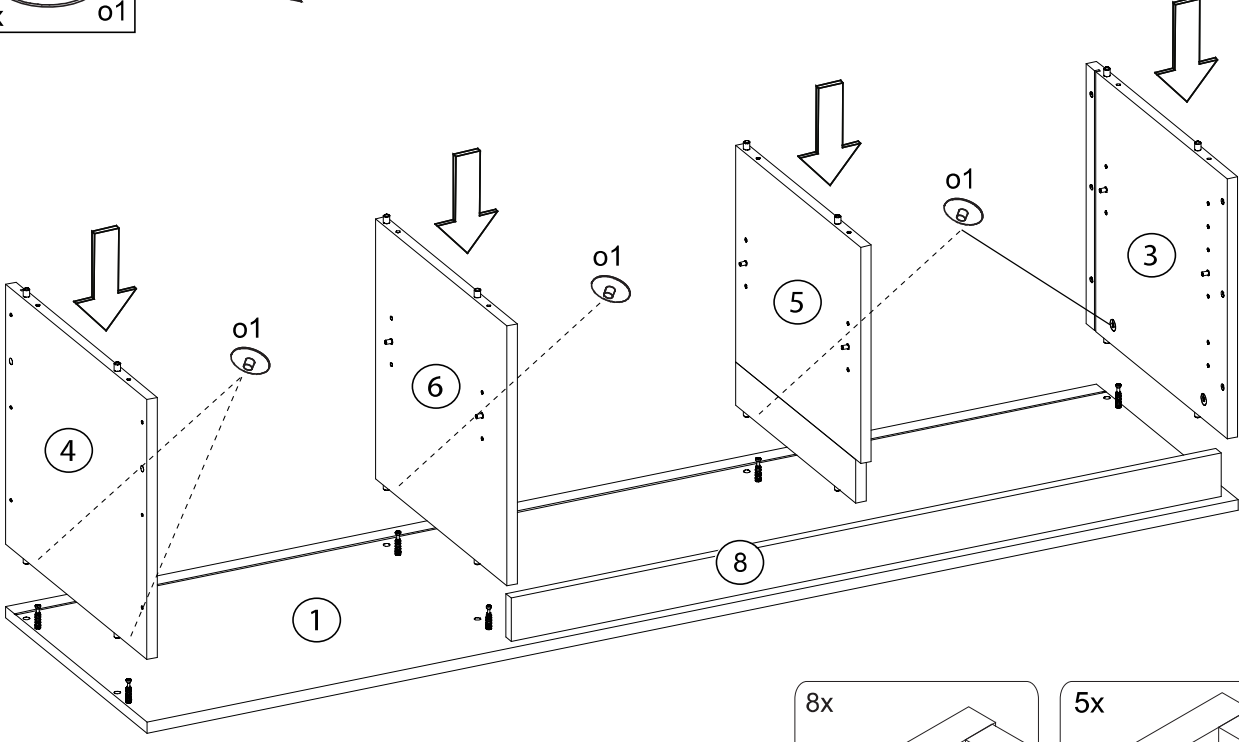
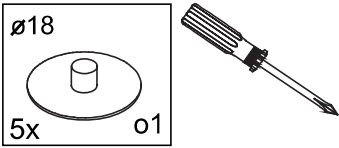

DEN54/137

K

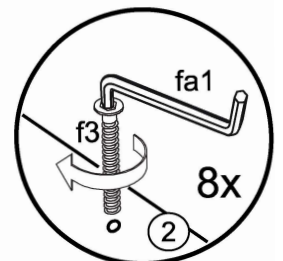
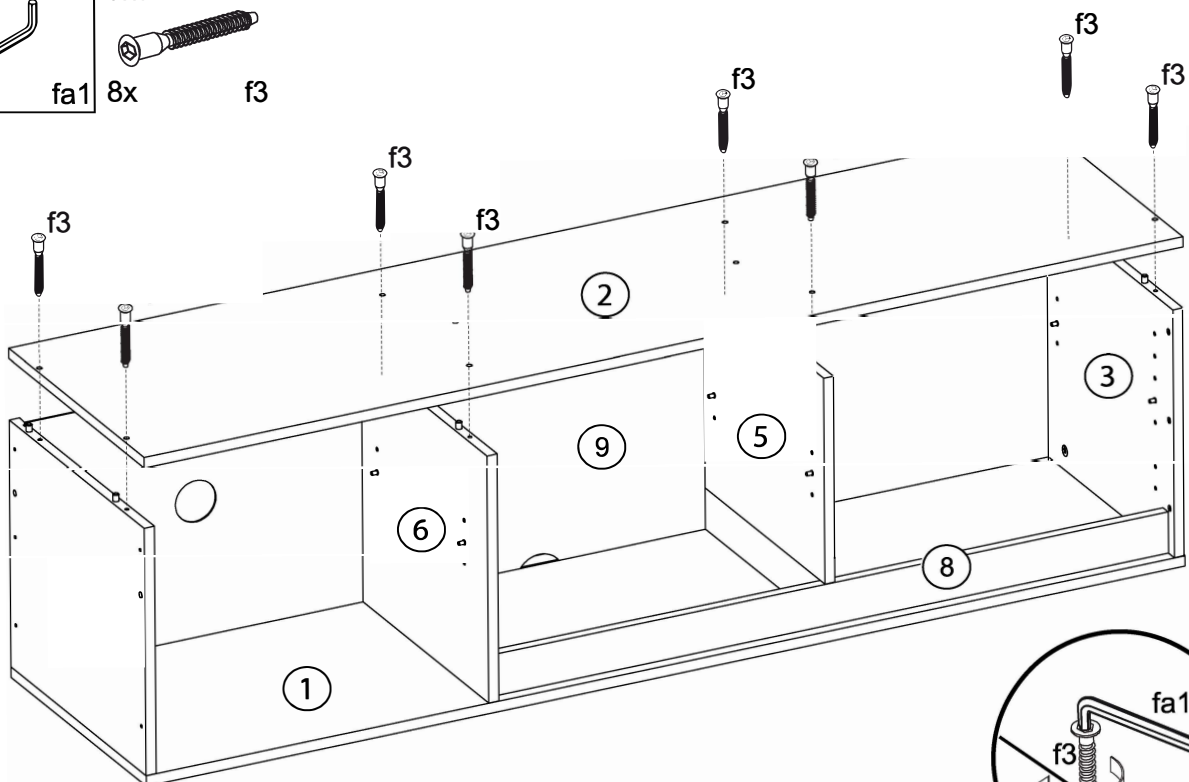
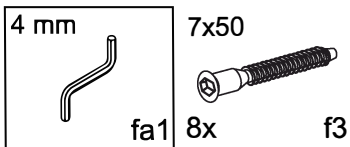
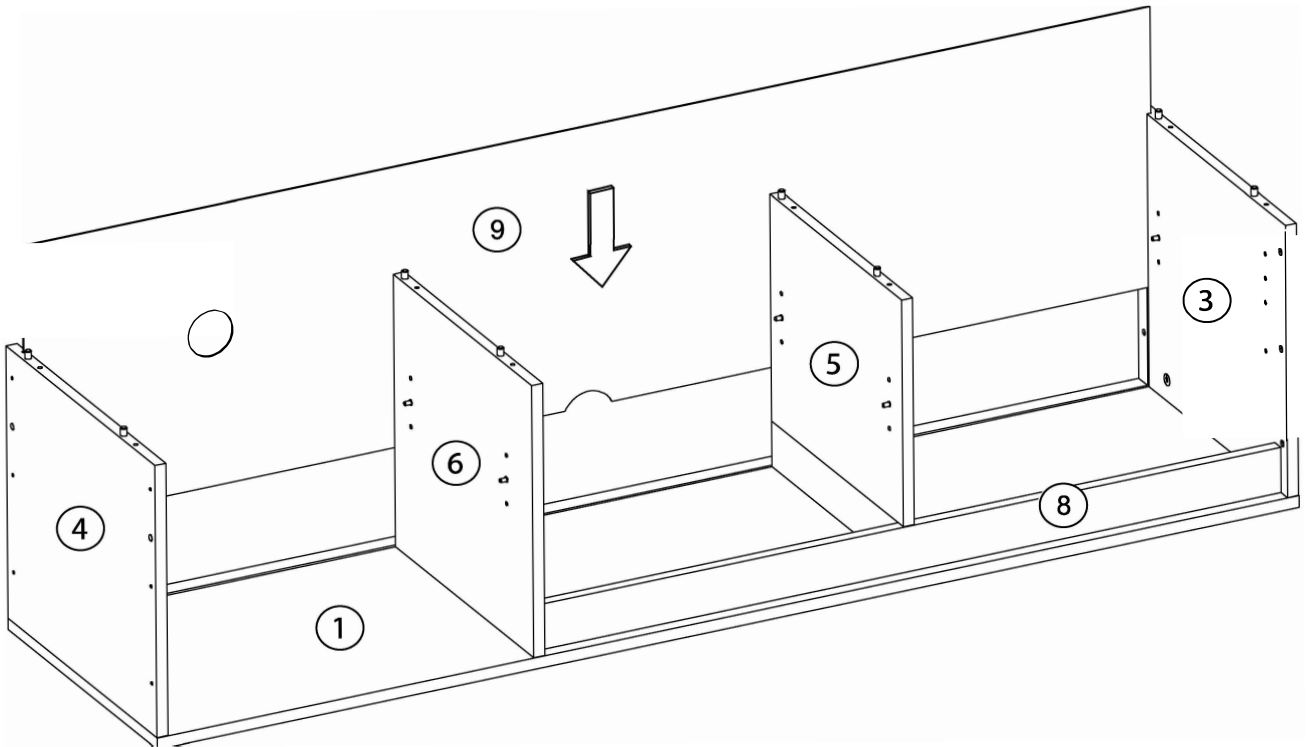

DEN54/137

M

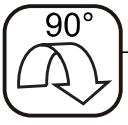
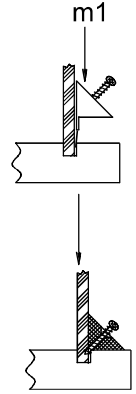
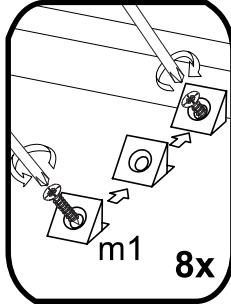
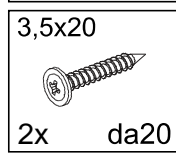
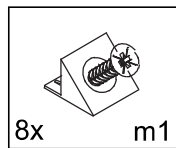
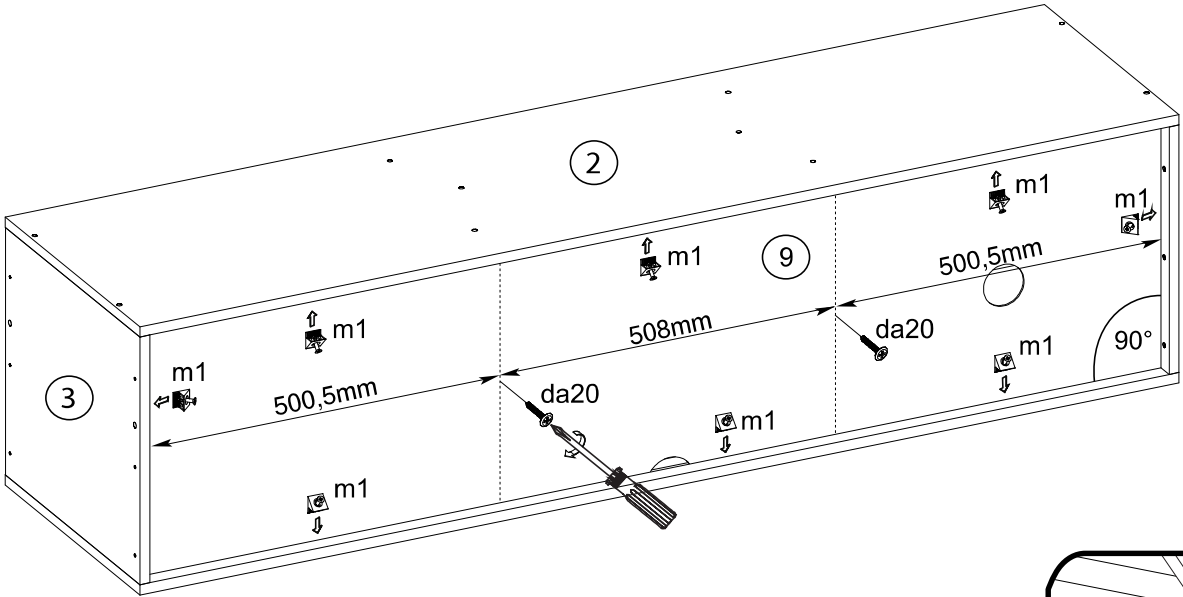

N

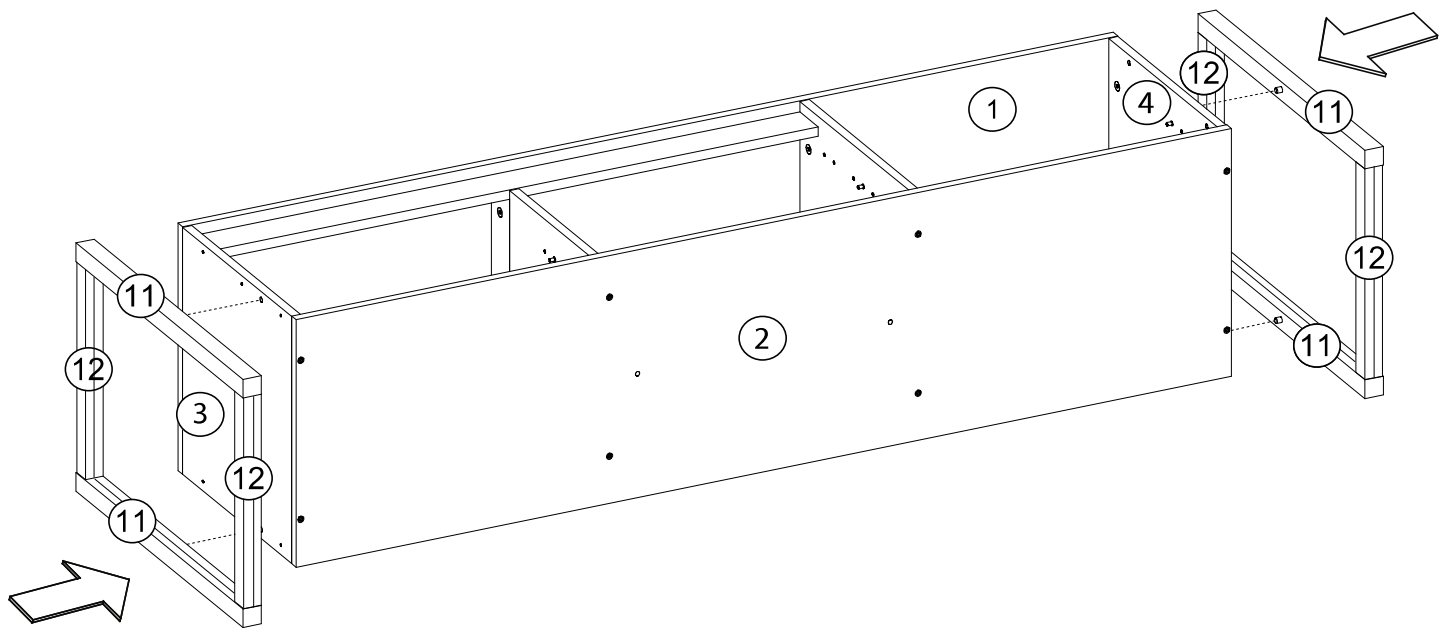

DEN54/137

O

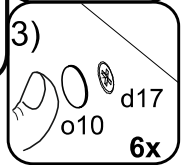
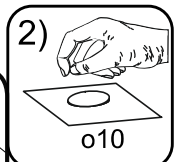
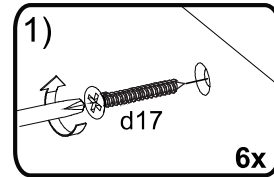
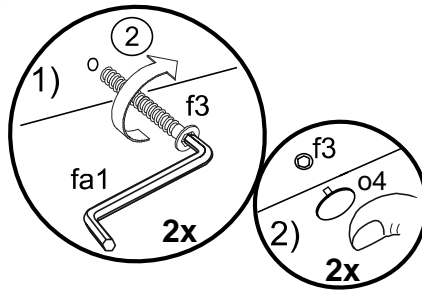
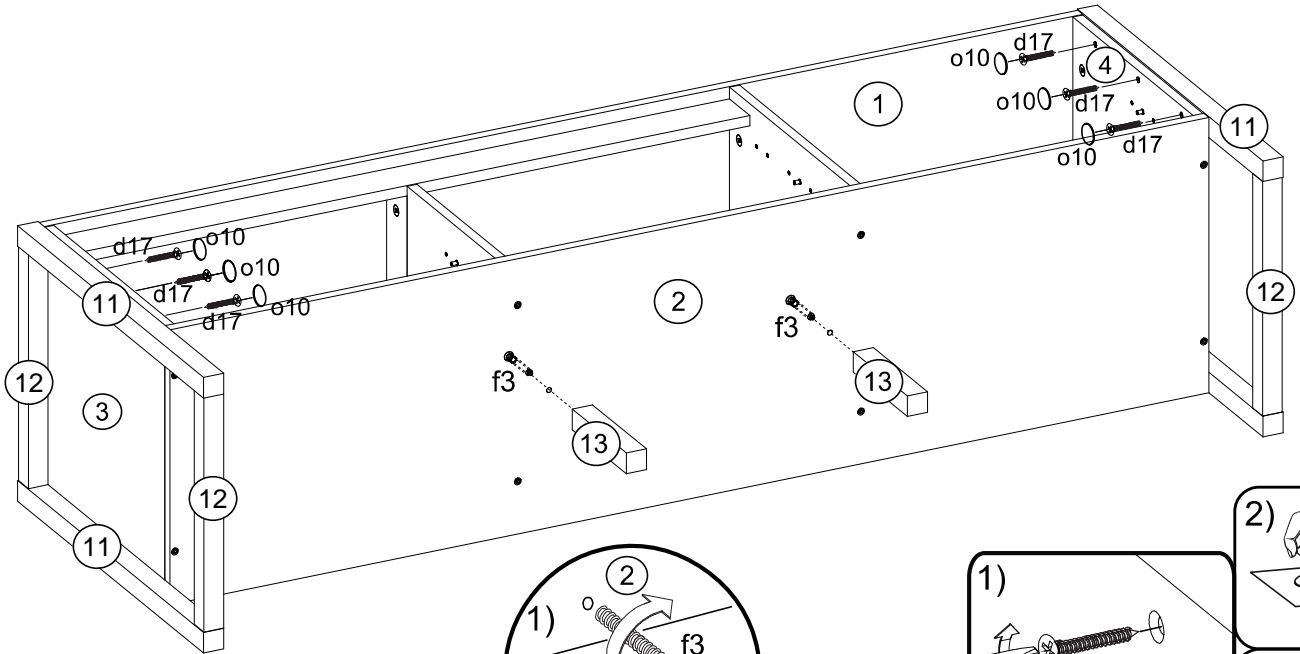
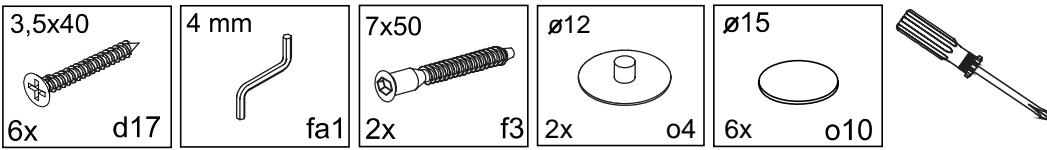

P

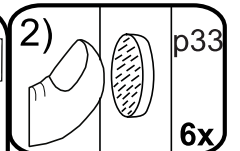
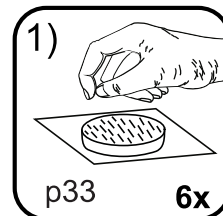
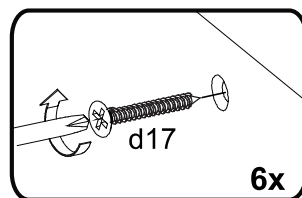
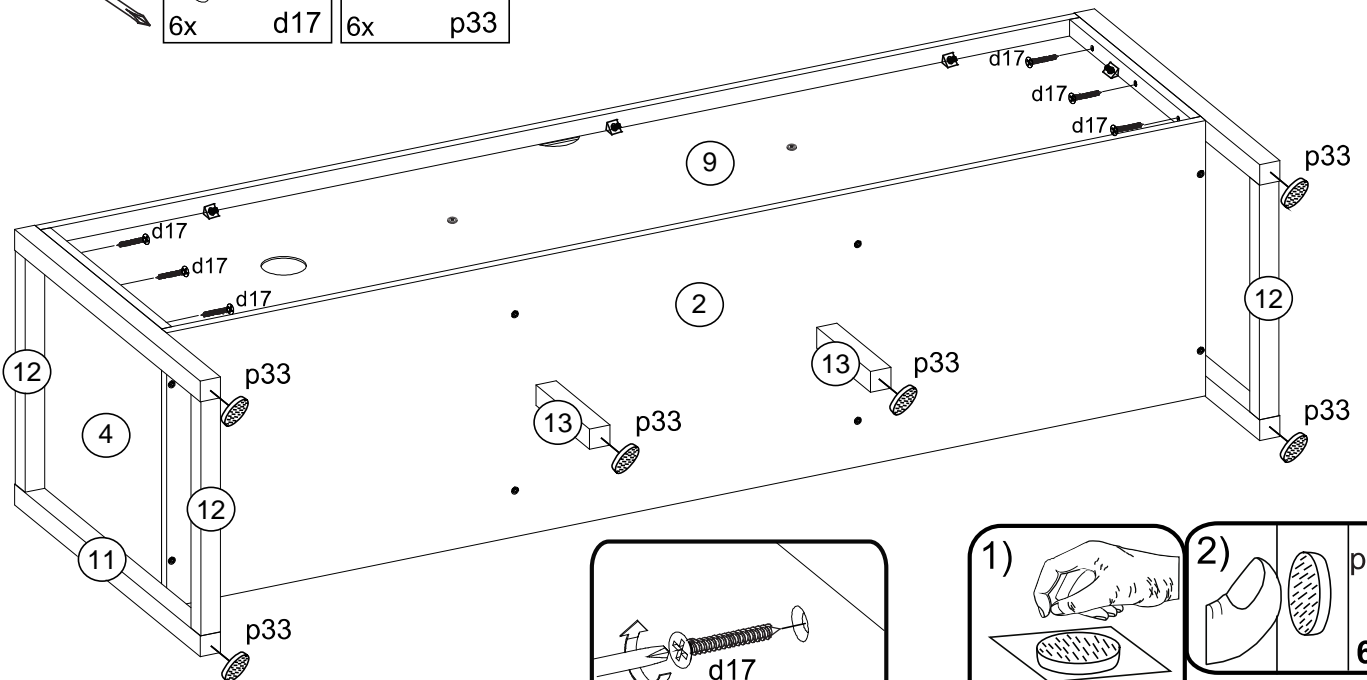
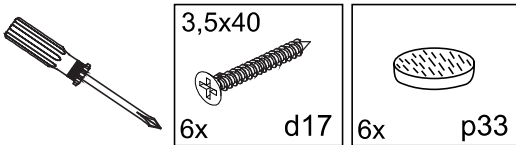

DEN54/137

R

Le meuble doit être fixé au mur!
 Das Möbel muss an der Wand befestigt werden!
 This unit must be secured to a wall
 using suitable fixing (not supplied)

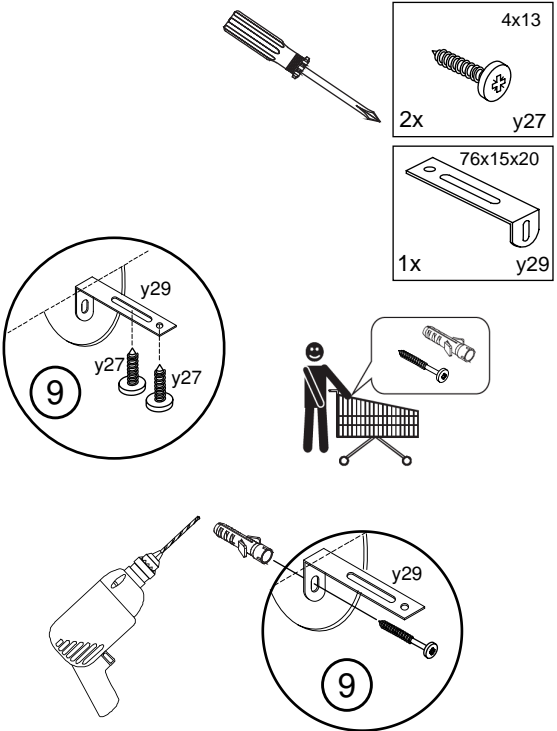
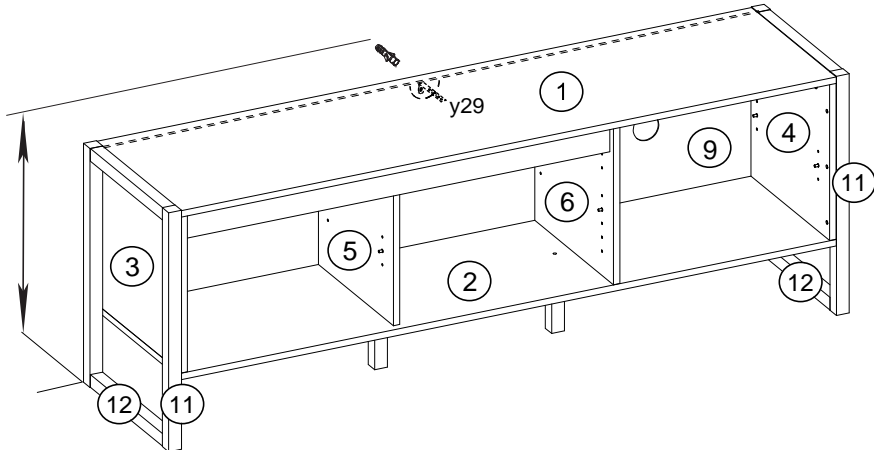

***Attention!**
 Veuillez-vous informer sur le type de cheville et vis approprié à la nature de votre mur.

***Achtung!**
 Informieren Sie sich vor der Wandmontage über das geeignete Montagematerial für Ihre Wand!

***Caution!**
 Please inform yourself about mounting material suitable for your wall before mounting.

S

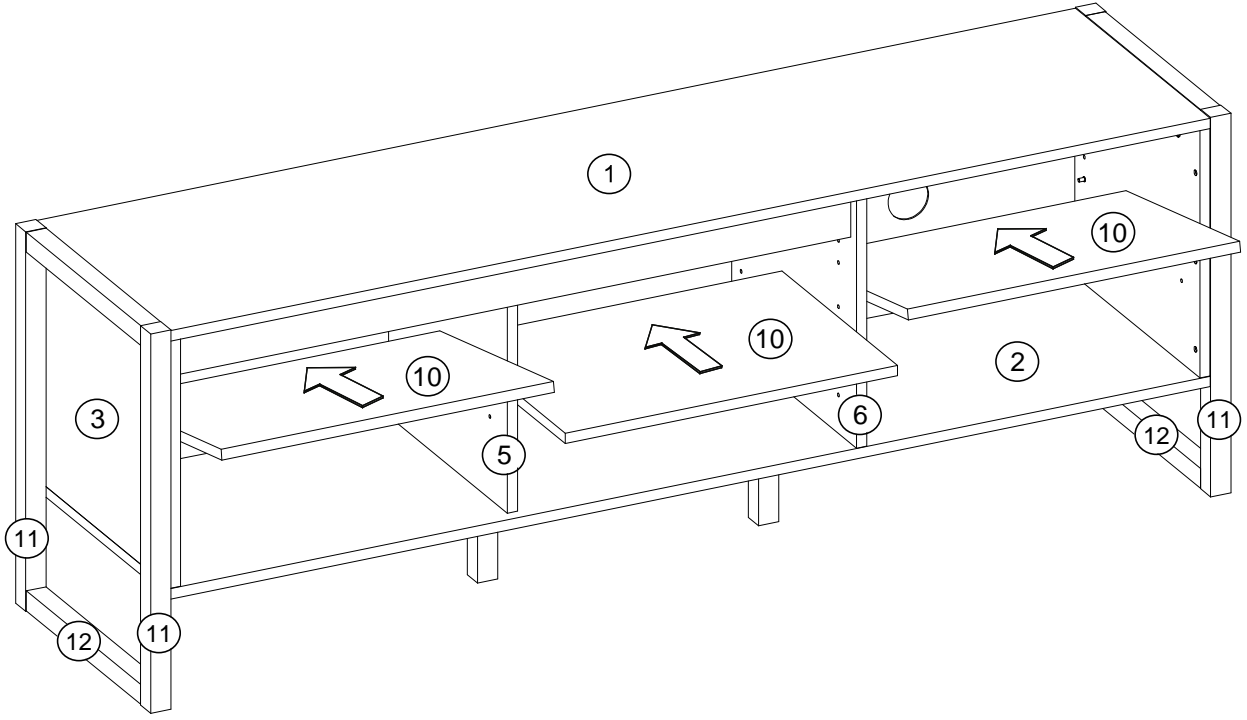

DEN54/137

T

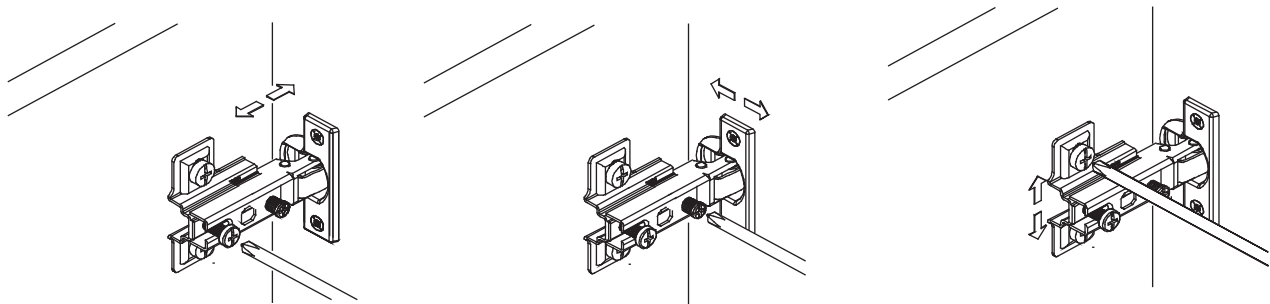
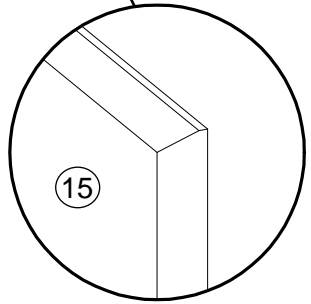
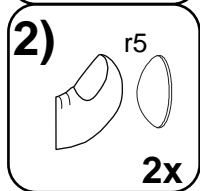
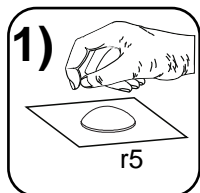
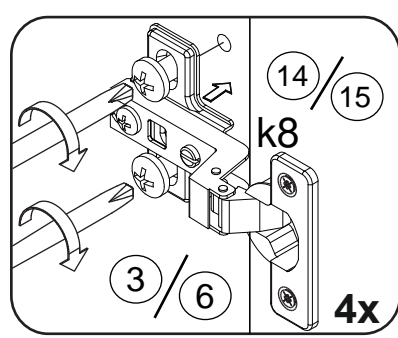
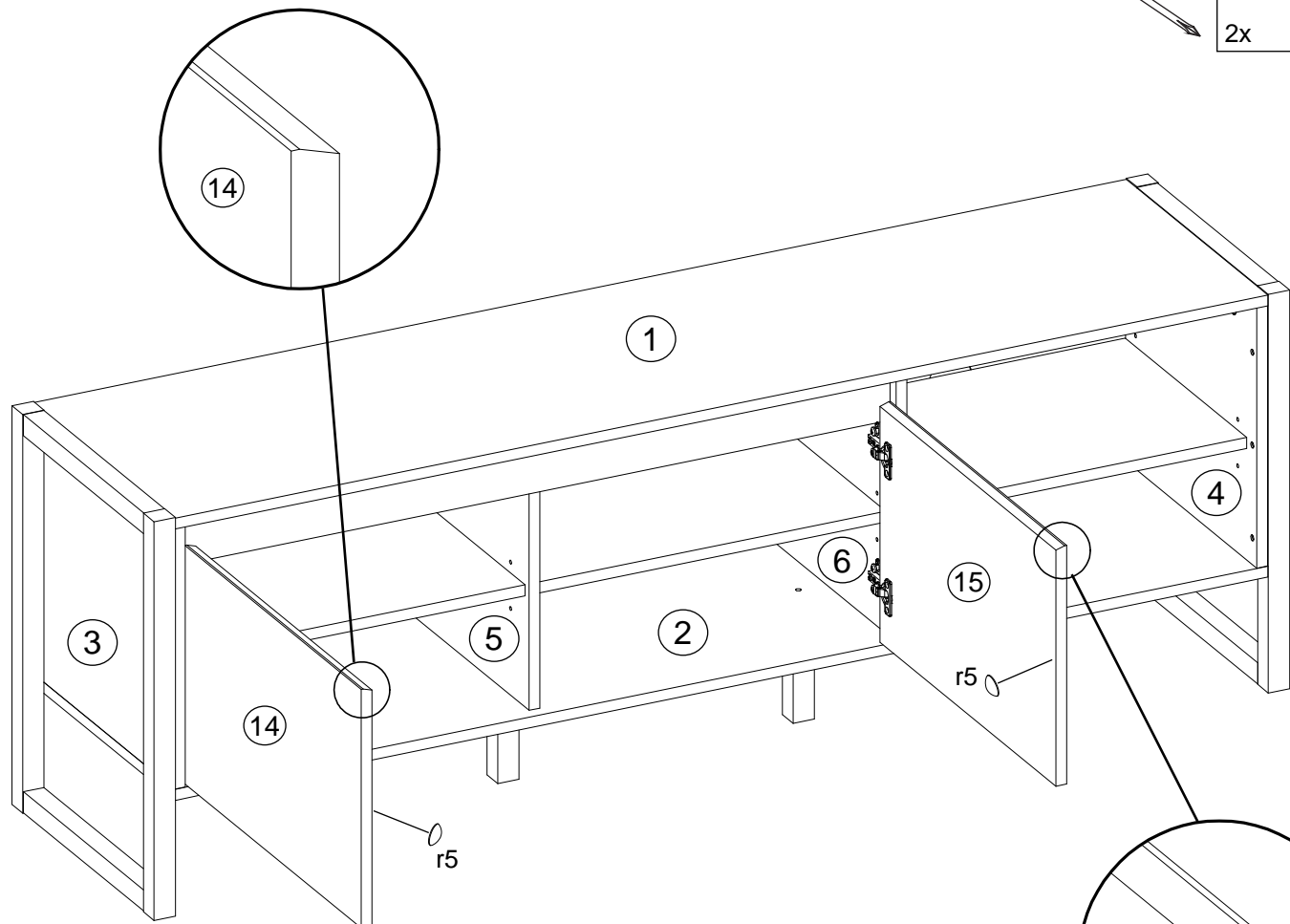
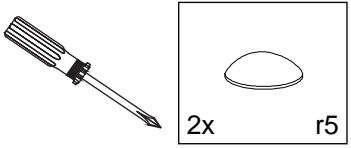

DEN54/137



- Ⓓ Das Möbel muss an der Wand befestigt werden!
- Ⓔ Please ensure to mount the furniture to the wall!
- Ⓕ Les meubles doivent être fixés au mur!
- Ⓝ Het meubel moet aan de wand worden vastgemaakt!
- Ⓔ El mueble se tiene que fijar a la pared!
- Ⓟ Mebel należy przymocować do ściany!

- Ⓜ Мебель должна крепиться к стене!
- Ⓣ Il mobile deve essere fissato alla parete!
- Ⓜ A bútor a falon rögzítendő!
- Ⓟ O móvel tem que ser fixado na parede!
- Ⓒ Nábytek musí být připevněn ke stěně!



- Ⓓ Informieren Sie sich vor der Wandmontage über das geeignete Montagematerial!
- Ⓔ Please get informed on suitable assembly materials before commencing the wall-mounting!
- Ⓕ Renseignez-vous sur le matériel de montage approprié avant le montage mural!
- Ⓝ Informeer u voor de wandmontage over het geschikte montagemateriaal!
- Ⓔ Infórmese antes del montaje en la pared del material apropiado de montaje!
- Ⓟ Przed montażem na ścianie upewnij się, jaki jest potrzebny właściwy materiał montażowy!

- Ⓜ Перед тем, как крепить мебель к стене, получите информацию о подходящем крепежном материале!
- Ⓣ Prima del fissaggio alla parete, informarsi sul materiale di montaggio adatto!
- Ⓜ A falra szerelés előtt tájékozódjon, hogy ehhez milyen szerelőanyagok szükségesek!
- Ⓟ Antes da montagem na parede, informe-se sobre o material de montagem adequado!
- Ⓒ Informujte se o vhodném montážním materiálu před montáží na stěnu!



- Ⓓ Beschaffen Sie sich das angemessene Material zur Wandbefestigung!
- Ⓔ Please obtain suitable wall-mounting materials!
- Ⓕ Procurez-vous le matériel approprié pour le montage mural!
- Ⓝ Verschaf u het adequate materiaal voor de wandbevestiging!
- Ⓔ Procúrese el material adecuado para la fijación a la pared!
- Ⓟ Zakup odpowiedni materiał do przymocowania na ścianie!

- Ⓜ Приобретите соответствующий материал для крепления к стене!
- Ⓣ Procurarsi il materiale opportuno per il fissaggio alla parete!
- Ⓜ Szerezze be a falra szereléshez szükséges, megfelelő anyagokat!
- Ⓟ Obtenha o material adequado para a montagem na parede!
- Ⓒ Opatřte si vhodný materiál pro montáž na stěnu!



- Ⓓ Lassen Sie die Wandbefestigung von einer fachkundigen Person vornehmen!
- Ⓔ Ensure all wall-mounting is carried out by competent personnel!
- Ⓕ Faites effectuer le montage mural par une personne compétente!
- Ⓝ Laat de wandbevestiging door een professional uitvoeren!
- Ⓔ Deje que la fijación a la pared la haga un profesional!
- Ⓟ Zlec przymocowanie do ściany odpowiednio doświadczonej osobie!

- Ⓜ Поручите выполнение работ по креплению к стене специалисту!
- Ⓣ Far effettuare il fissaggio alla parete ad un esperto!
- Ⓜ A bútor falra rögzítését végeztesse ehhez értő személlyel!
- Ⓟ A montagem na parede deve ser executada por uma pessoa competente!
- Ⓒ Montáž na stěnu nechte provést odborně způsobilou osobou!

