

- (D) **Montageanleitung**
- (NL) **Handleiding voor de montage**
- (TR) **Montaj talimatı**
- (F) **Notice de montage**
- (CZ) **Montážní návod**
- (HU) **Szerelési útmutató**
- (GB) **Assembly instructions**
- (PL) **Instrukcja montażu**
- (RU) **Инструкция по монтажу**
- (IT) **Istruzioni di montaggio**
- (SK) **Návod na montáž**
- (RO) **Instrucțiuni de montaj**

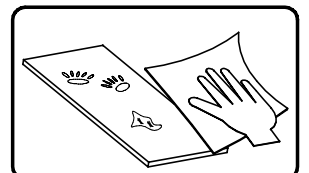
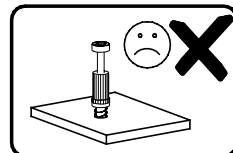
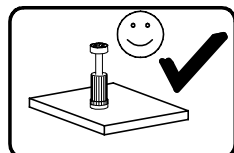
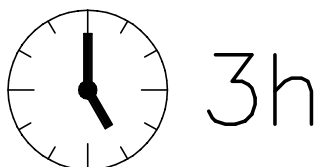
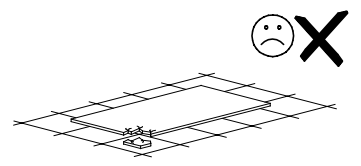
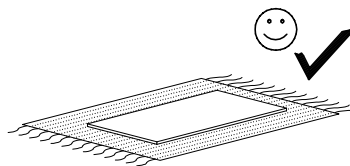
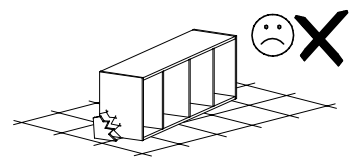
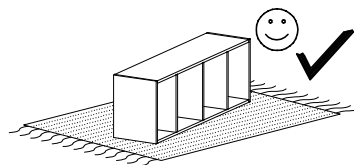
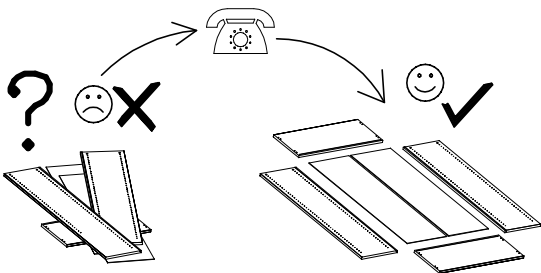
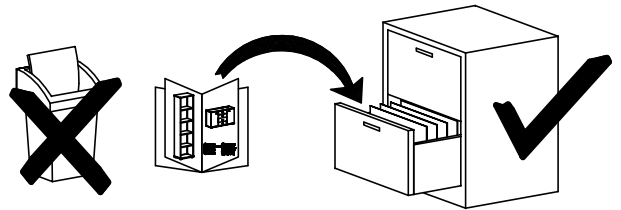
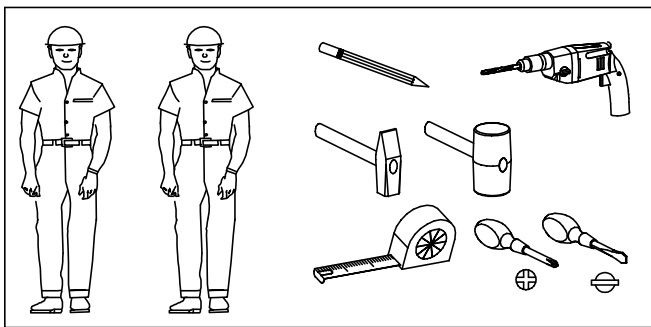

Name • Nom • Nome • Naam • Nazwa • Jméno
• Názov • Név • Denumire • Isim • Название

Nr • No • N° • Номер • Č • Sz

Typ • Type • Tip • Típus • Tipo • Tun

VALENCIA

— —

VITRINE 4

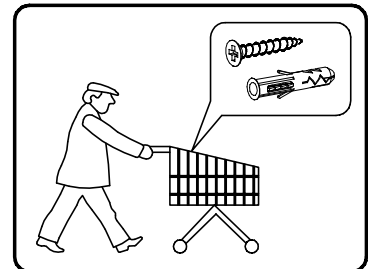
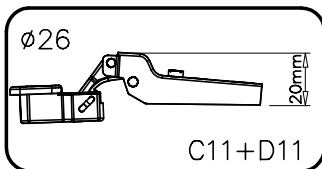
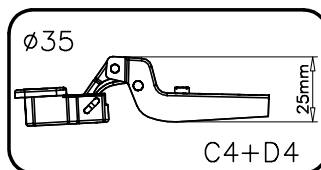
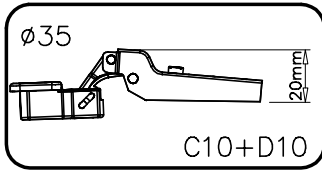
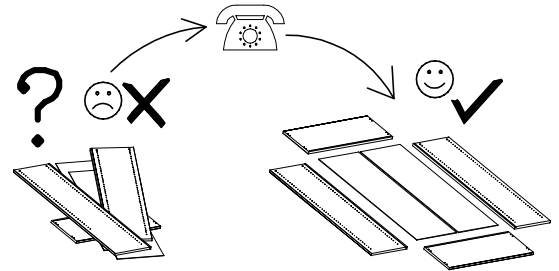
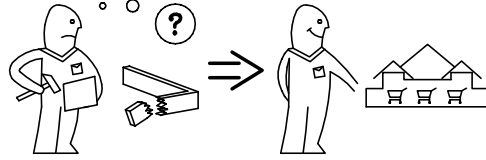
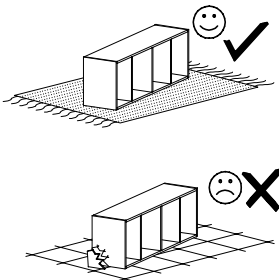

				G18 6x33 x...(4)
C11 Z26PL x...(6)	D11 PZ26PL x...(6)	S2 x...(24)	M11 x...(2)	G14 3,5x45 x...(8)
W1 x...(3)	H23 H35-300mm x...(4)	I28 ø29 x...(12)	G20 5x11 x...(28)	A6 ø7x40 x...(16)
F12 x...(8)		C10 Z35PL x...(4)	G53 5x20 x...(4)	K4 ø12x10 x...(8)
F15 x...(31)	W2 x...(1)	D10 PZ35PL x...(4)	I1 x...(26)	G34 3,5x16 x...(278)
K1 ø15x12 x...(76)	F2 x...(16)	P4 x...(15)	C4 Z350D x...(10)	N14 M4x22 x...(24)
K10 x...(84)	B1 ø8x35 x...(76)	I7 x...(76)	D4 PZ350D x...(10)	E102 mm x...(12)

Name • Nom • Nome • Naam • Nazwa • Jméno • Názov • Név • Denumire • Isim • Название <h1 style="text-align: center;">VALENCIA</h1>	Nr • No • N° • Номер • Č • Sz <p style="text-align: center;">---</p>	Typ • Type • Tip • Típus • Tipo • Tun <h2 style="text-align: center;">VITRINE 4</h2>
---	---	---

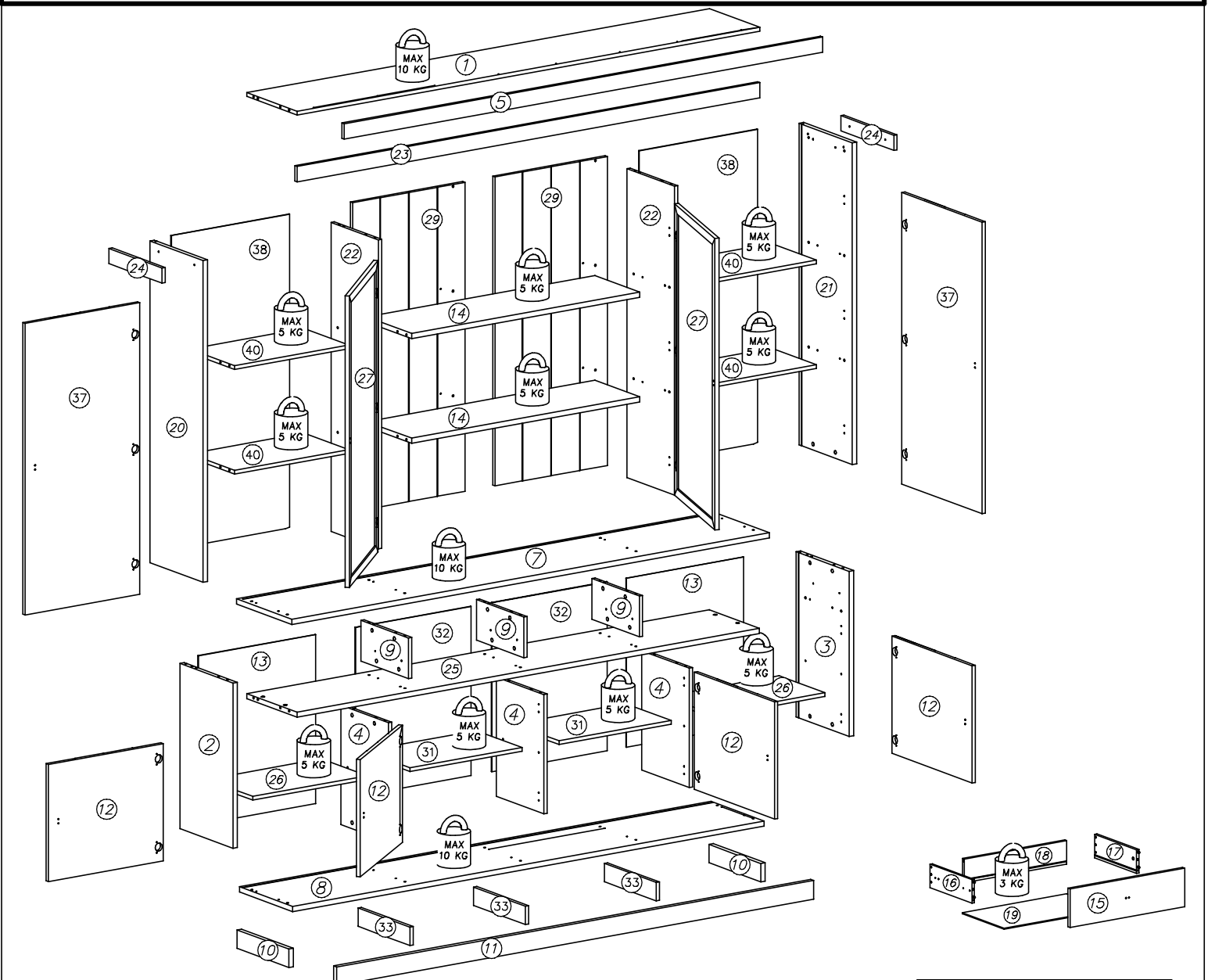
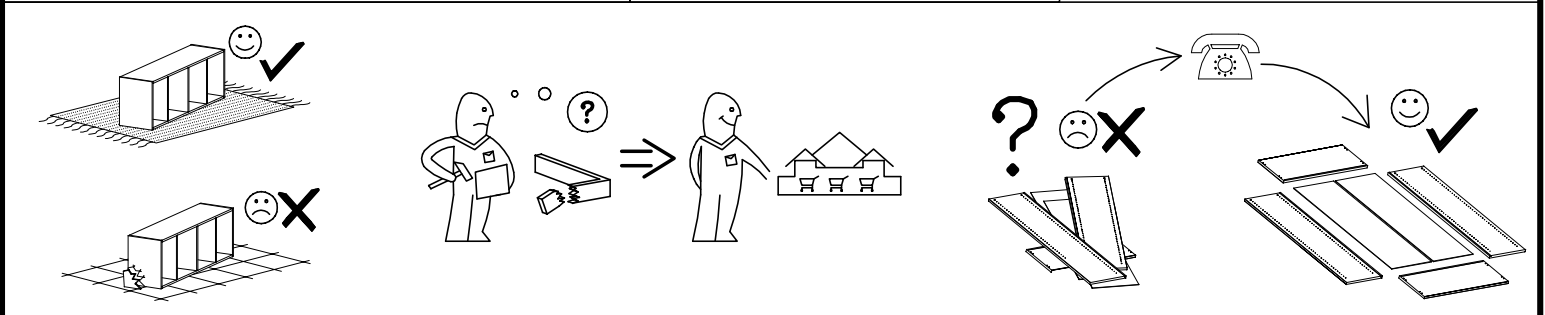

nr	L[mm]	B[mm]	T[mm]	Menge	Colli
1	2320	360	16	1	2/7
2	702	380	22	1	4/7
3	702	380	22	1	4/7
4	507	340	16	3	3/7
5	2400	65	16	1	2/7
7	2394	396	22	1	2/7
8	2364	381	22	1	3/7
9	173	340	16	3	3/7

nr	L[mm]	B[mm]	T[mm]	Menge	Colli
10	371	79	22	2	2/7
11	2392	79	22	1	2/7
12	498	575	16	4	1/7
13	714	585	3	2	6/7
14	1144	322	22	2	5/7
15	575	164	16	4	1/7
16	300	100	12	4	1/7
17	300	100	12	4	1/7

nr	L[mm]	B[mm]	T[mm]	Menge	Colli
18	513	100	12	4	1/7
19	523	301	3	3	1/7
20	1367	380	22	1	4/7
21	1367	380	22	1	4/7
22	1313	340	16	2	5/7
23	2320	65	16	1	2/7
24	380	64	16	2	2/7
25	2318	359	22	1	3/7

nr	L[mm]	B[mm]	T[mm]	Menge	Colli
26	572	328	16	2	1/7
27	1239	575	16	1	7/7
29	1313	572	16	2	6/7
31	562	328	16	2	5/7
32	714	577	3	2	6/7
33	371	79	16	3	2/7
37	1239	575	16	2	7/7
38	1334	593	3	2	6/7
40	572	340	16	4	1/7



(A)

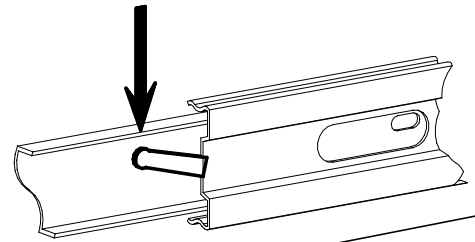
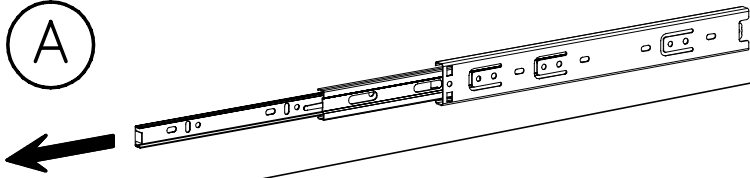

(B)

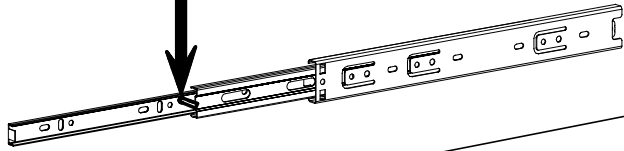

(C)

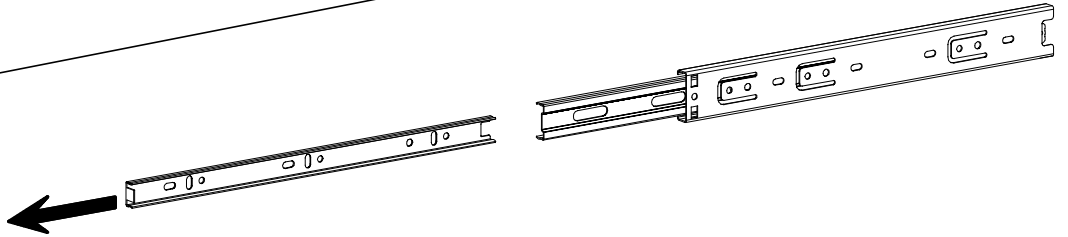

I

G20

H23

3x

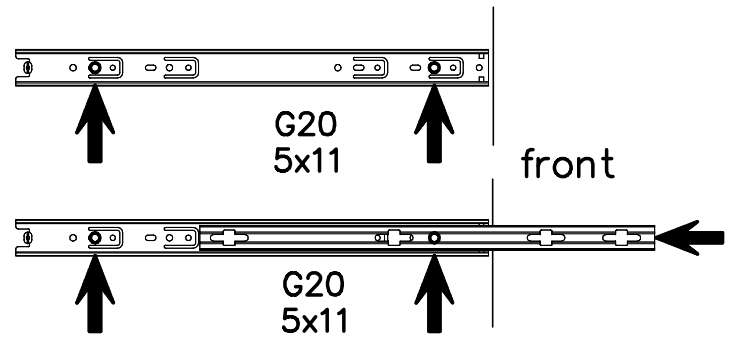
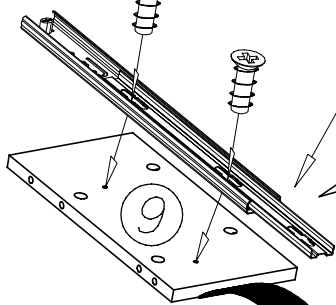

G20

H23

3x

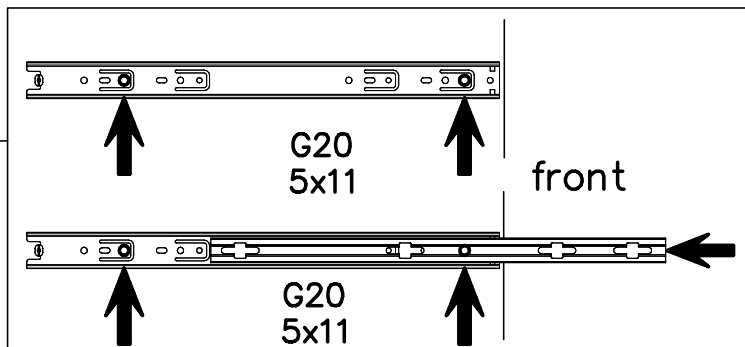
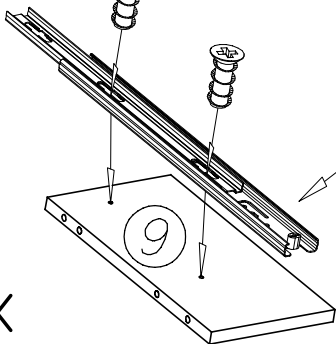



II

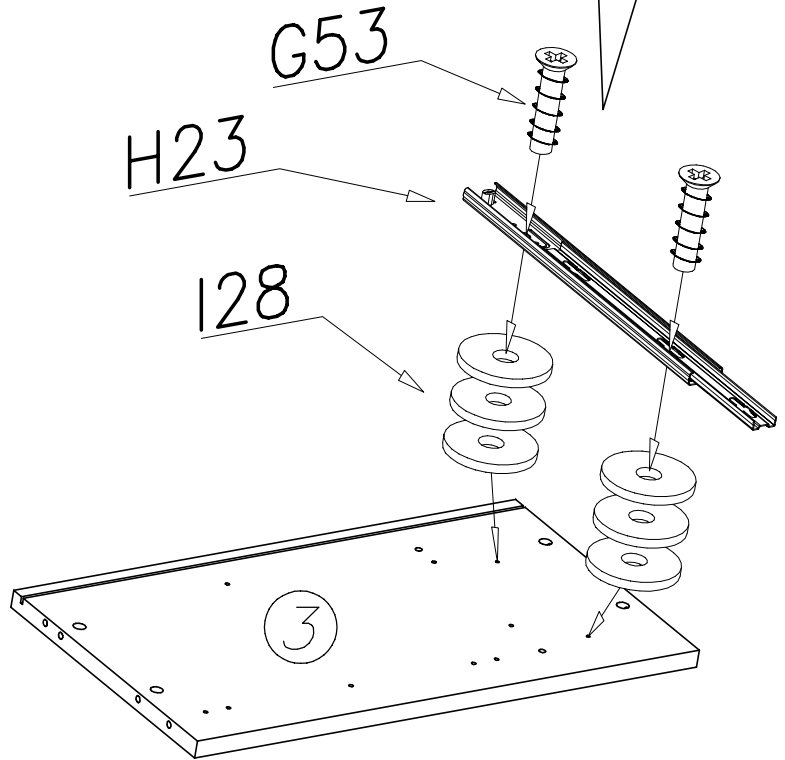
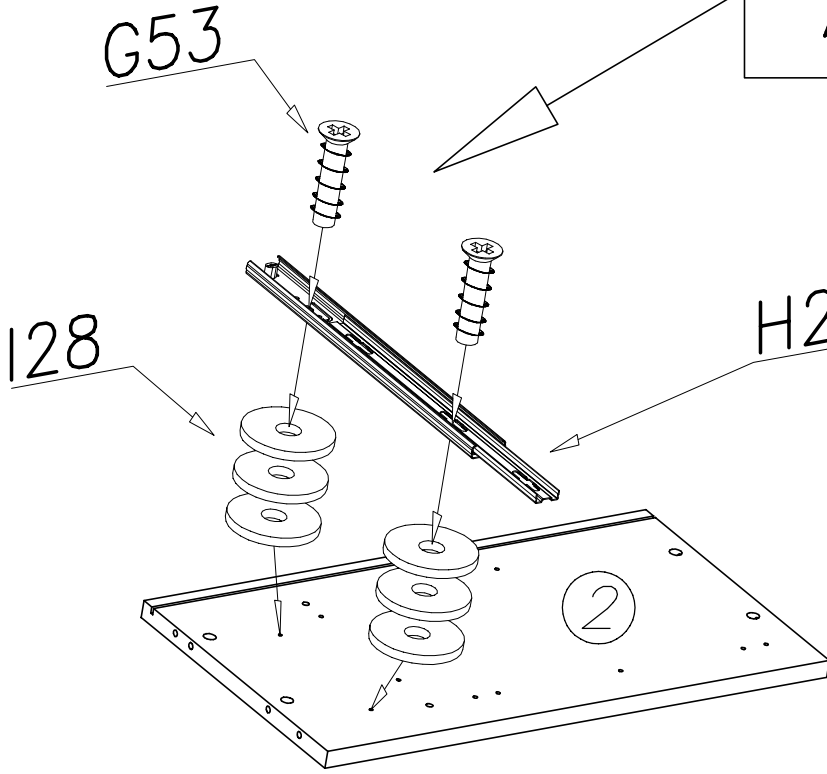
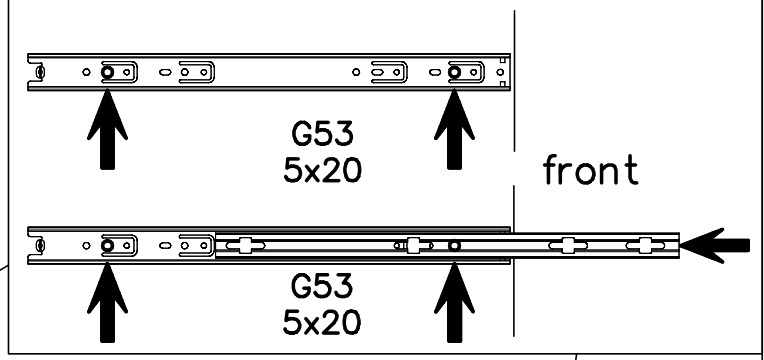



III

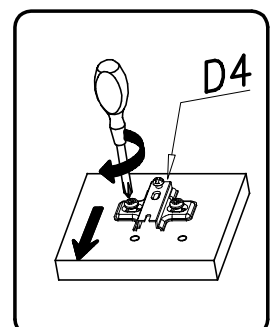
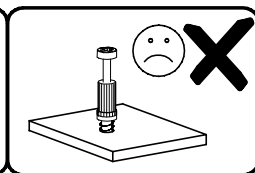
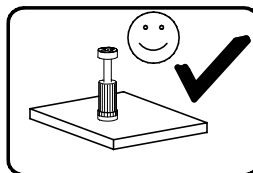
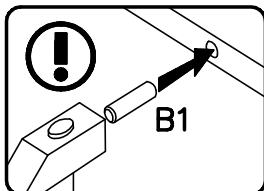
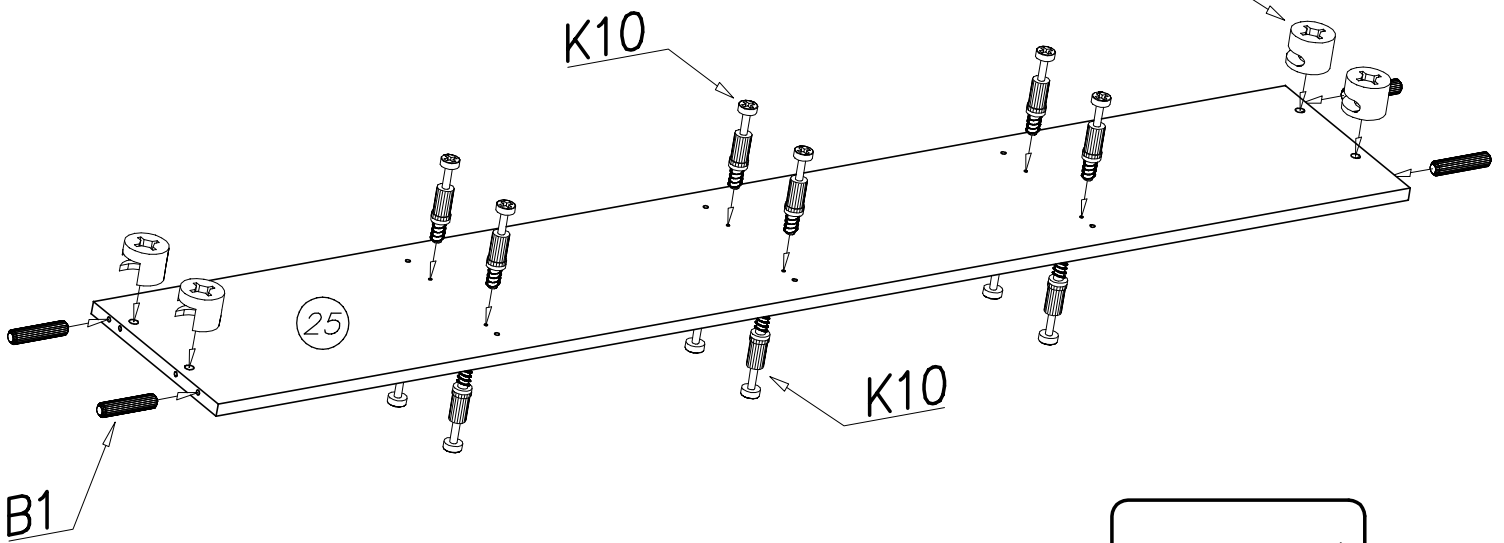
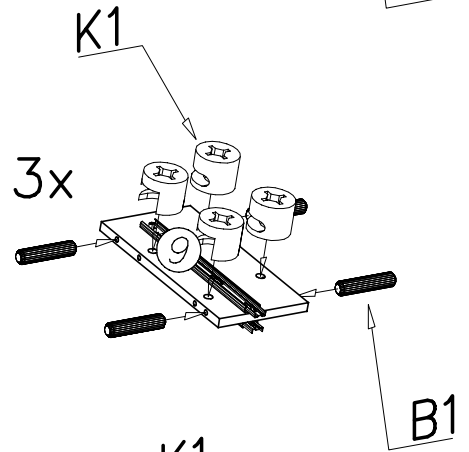
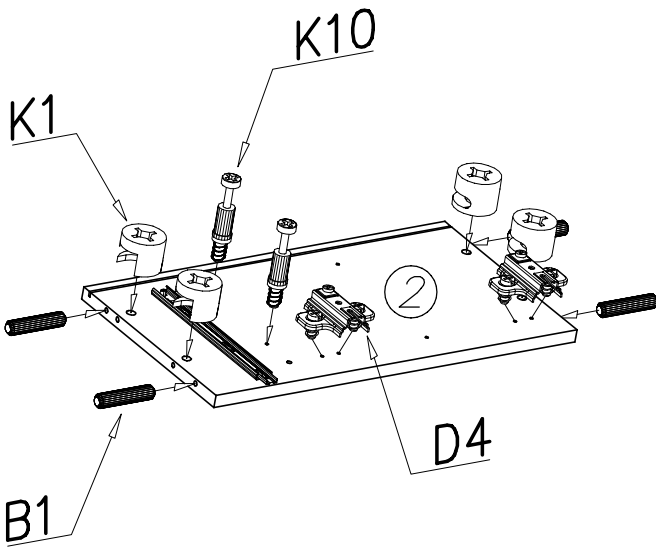
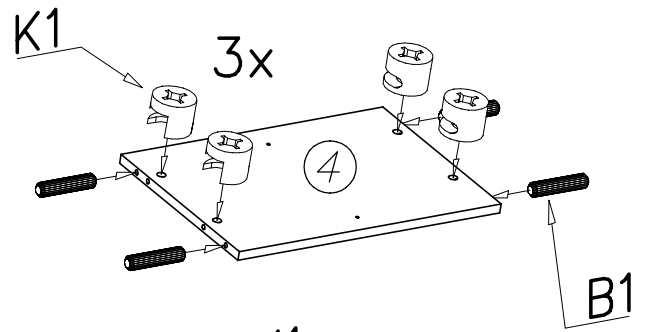
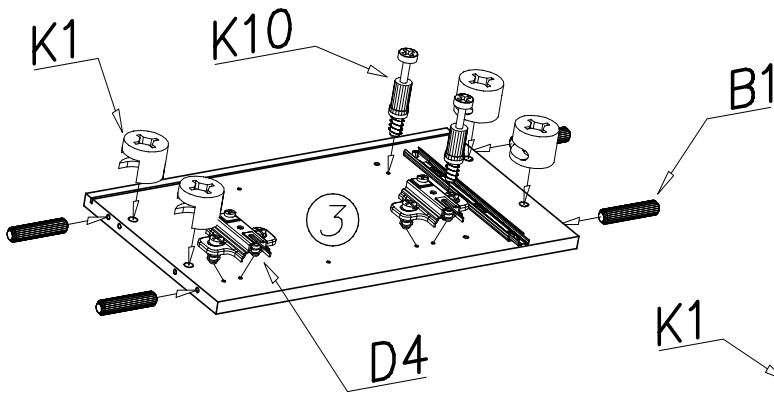



IV

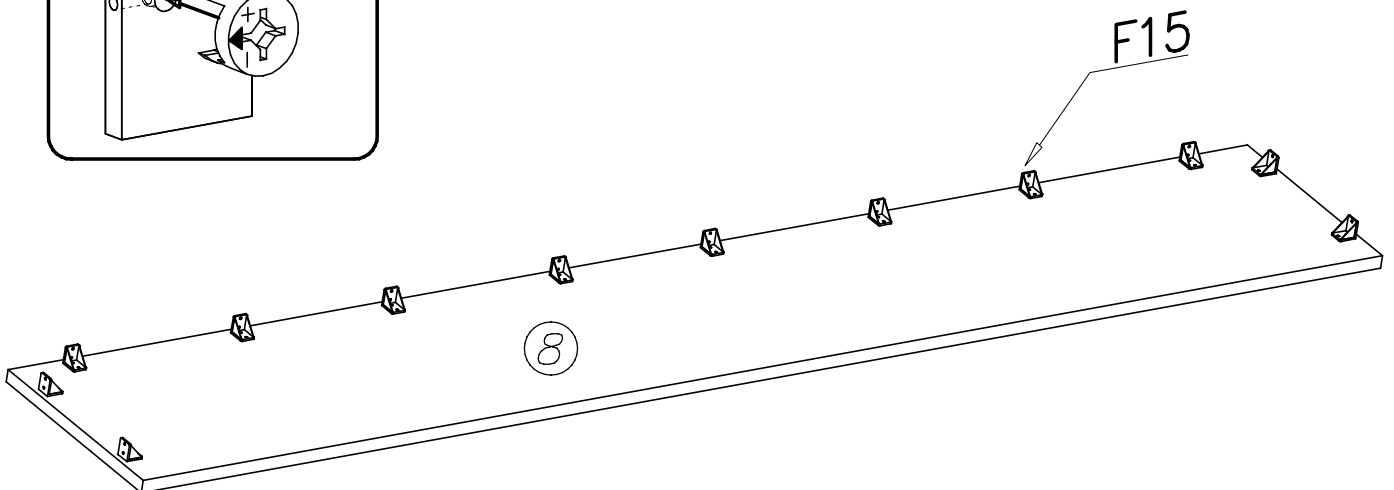
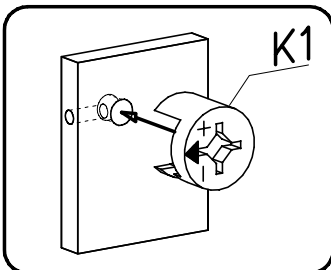
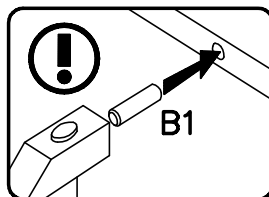
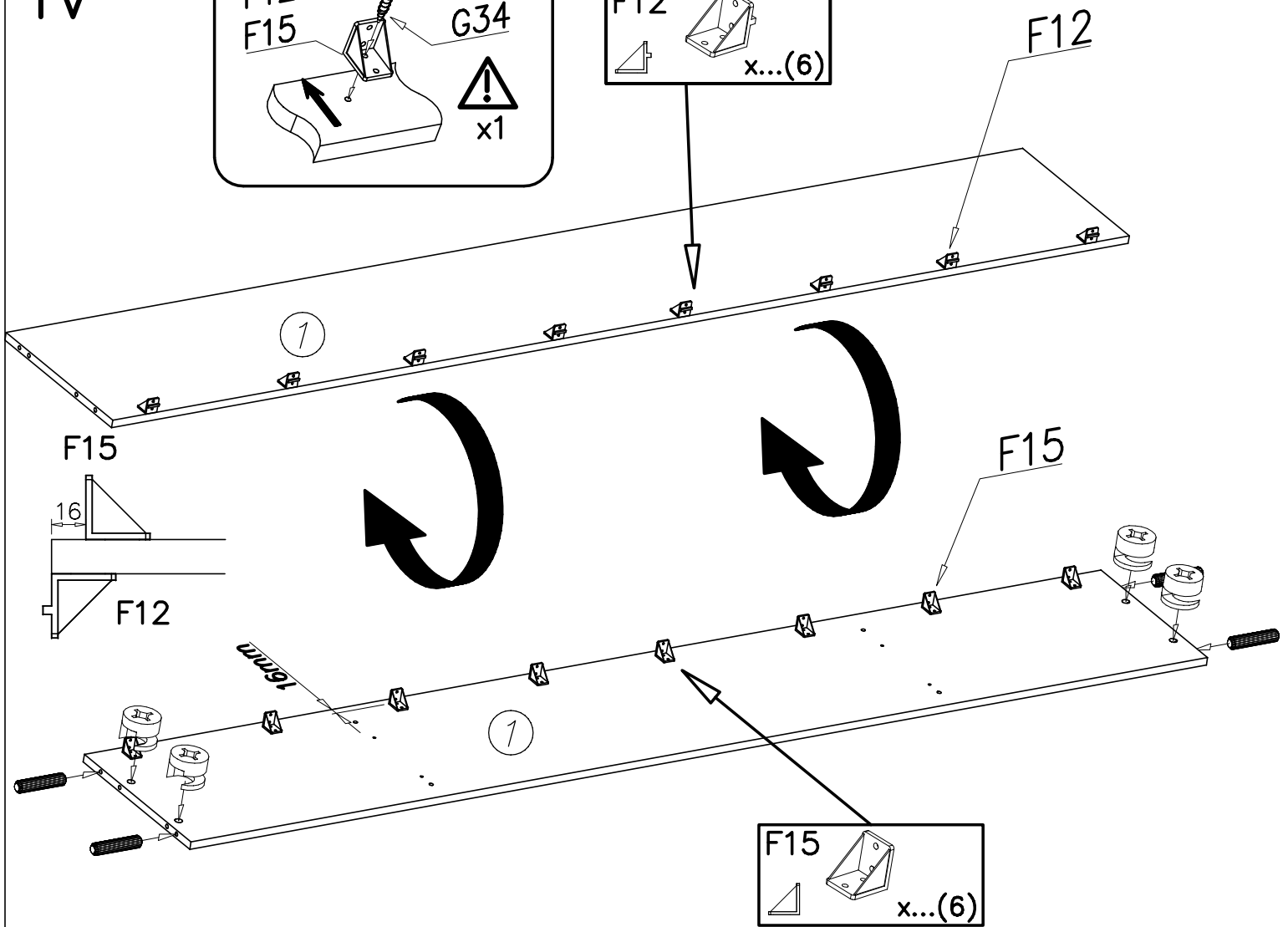
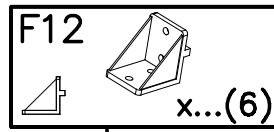
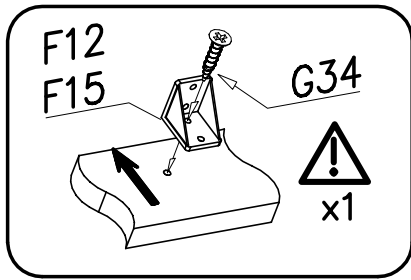

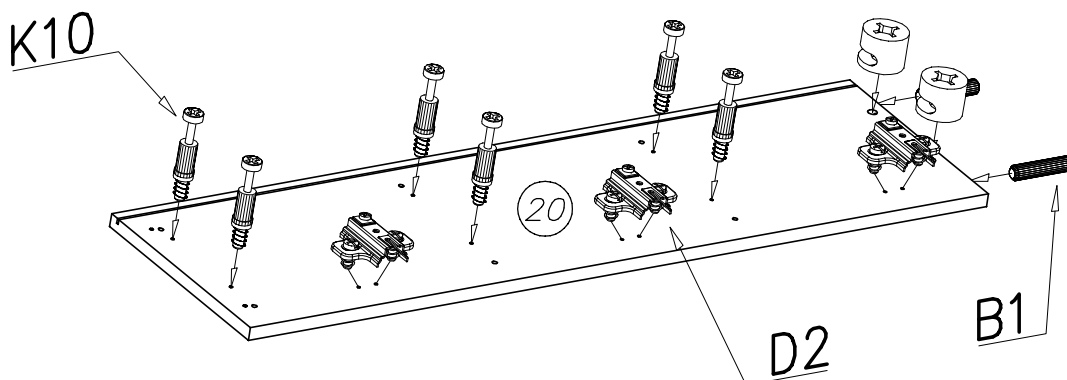
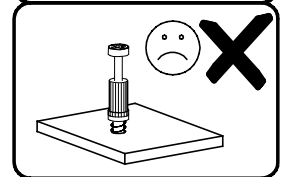
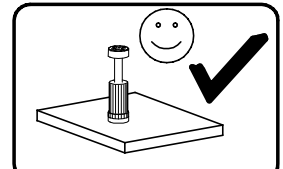
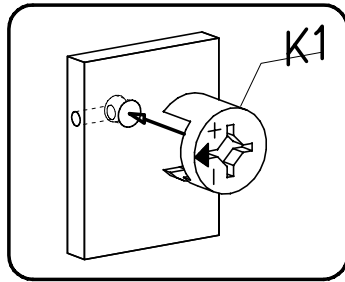
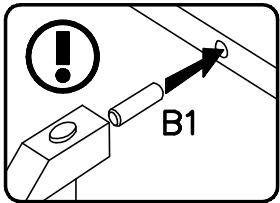
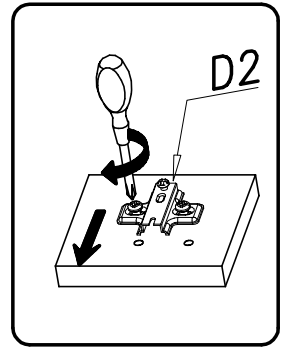
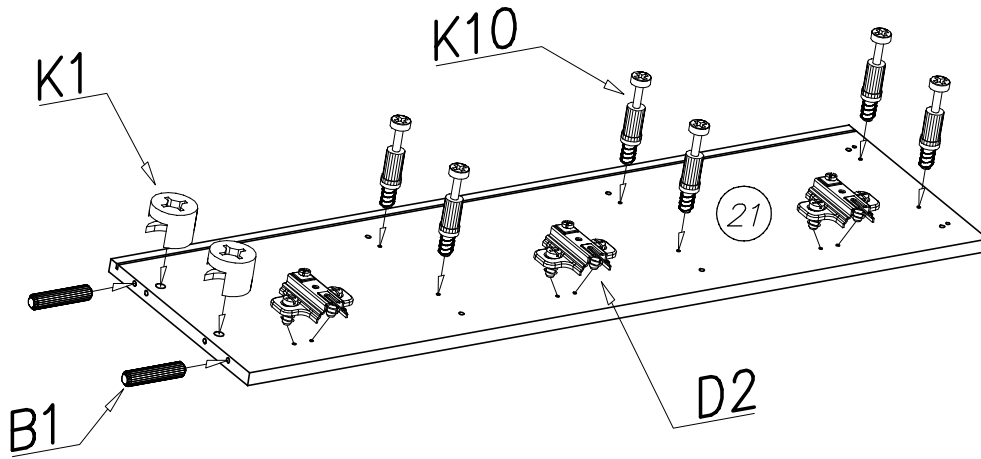
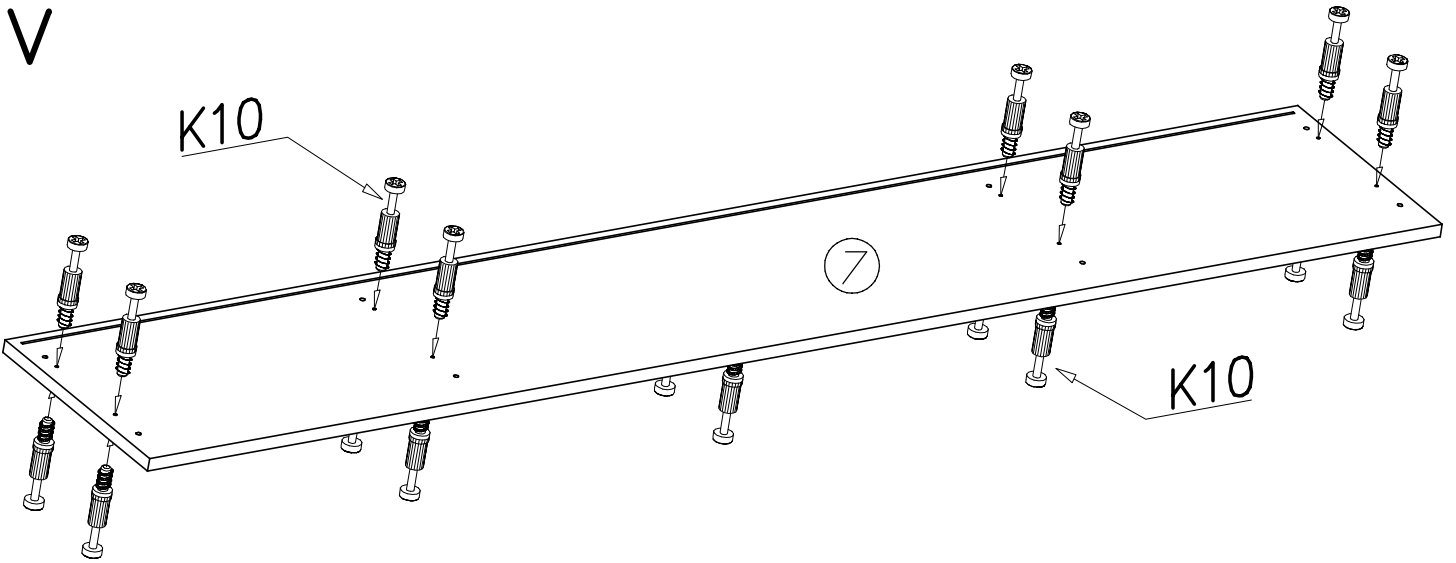



VI

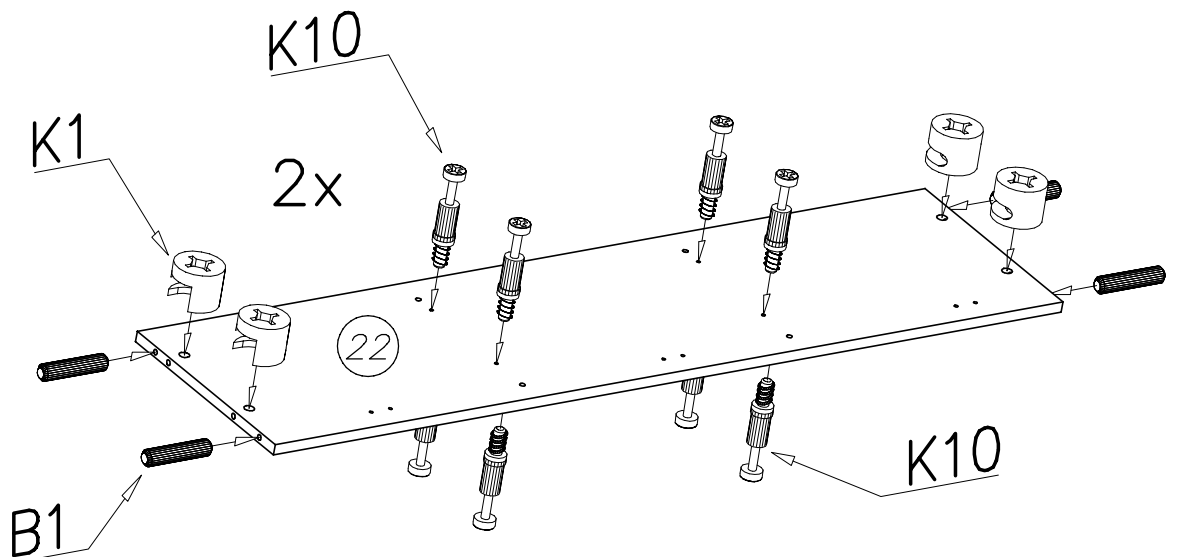
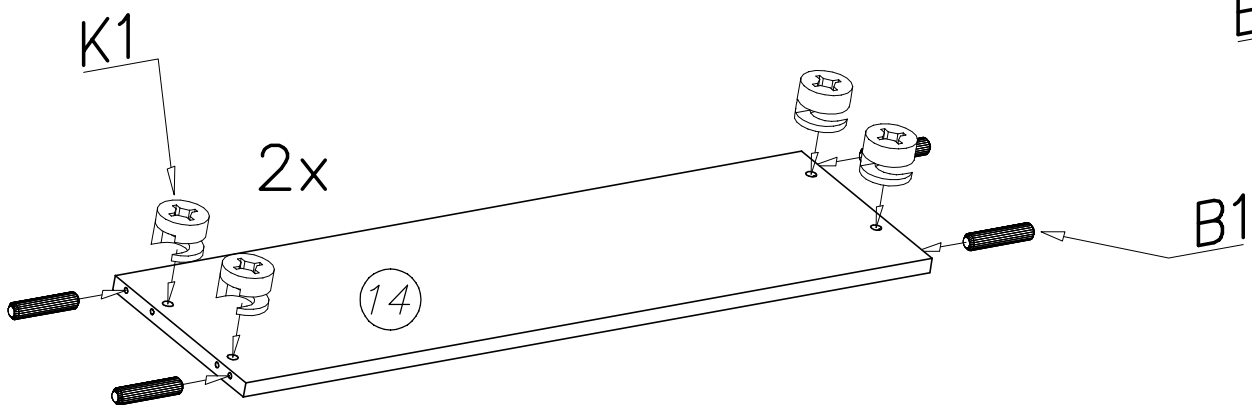
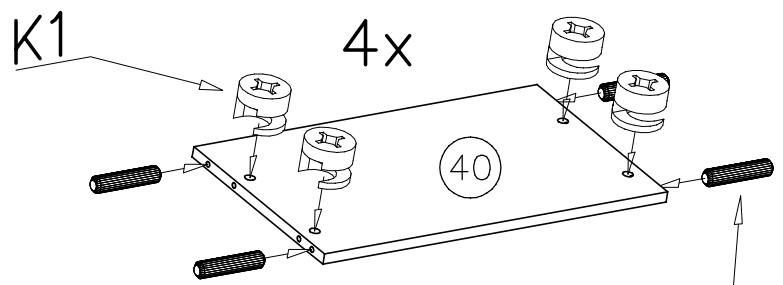
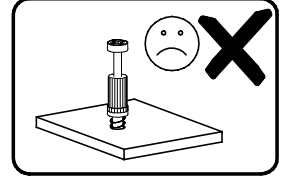
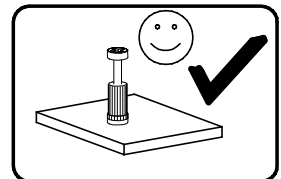
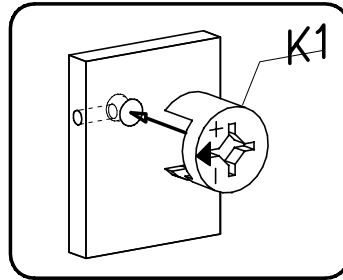
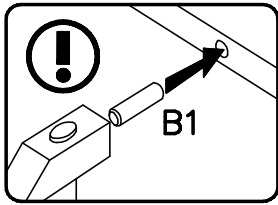



VII

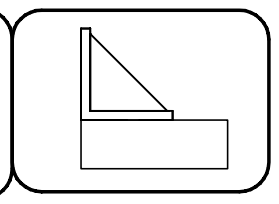
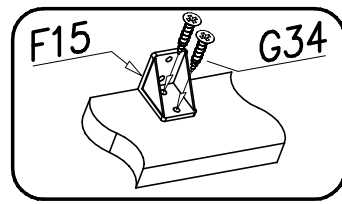
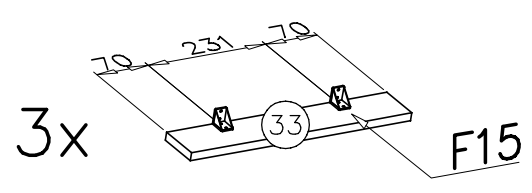

VIII

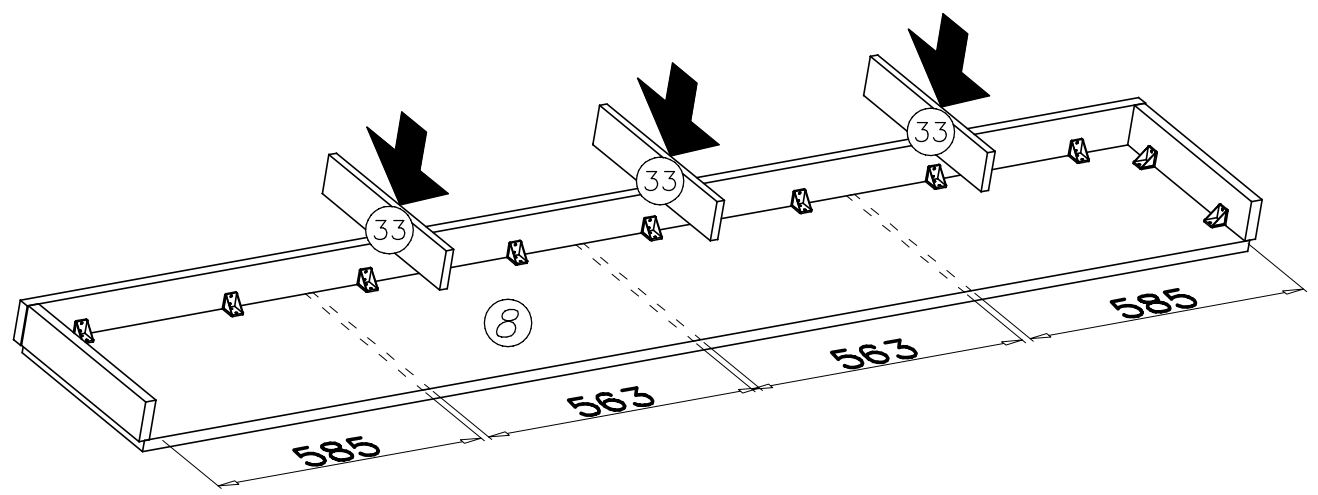
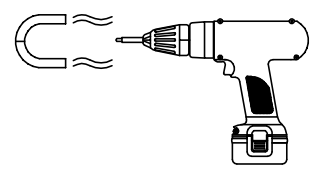
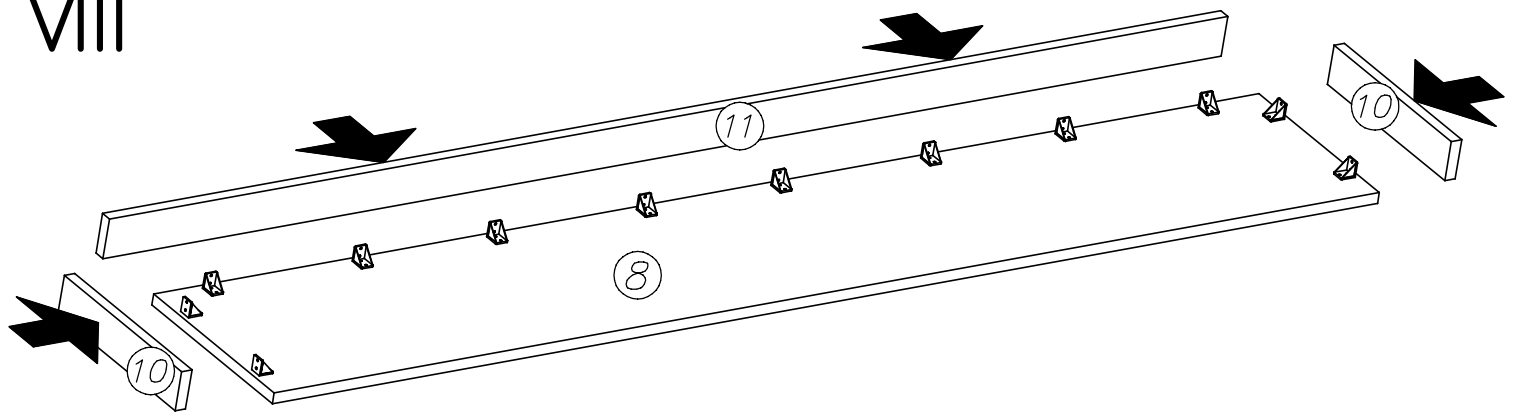

1.

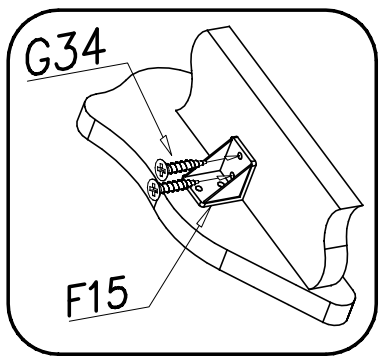

2.

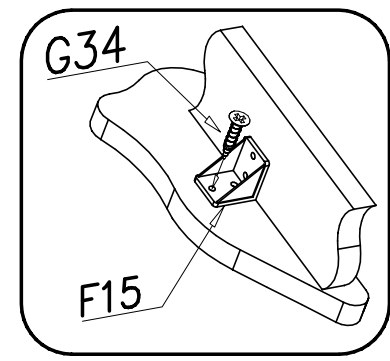



IX

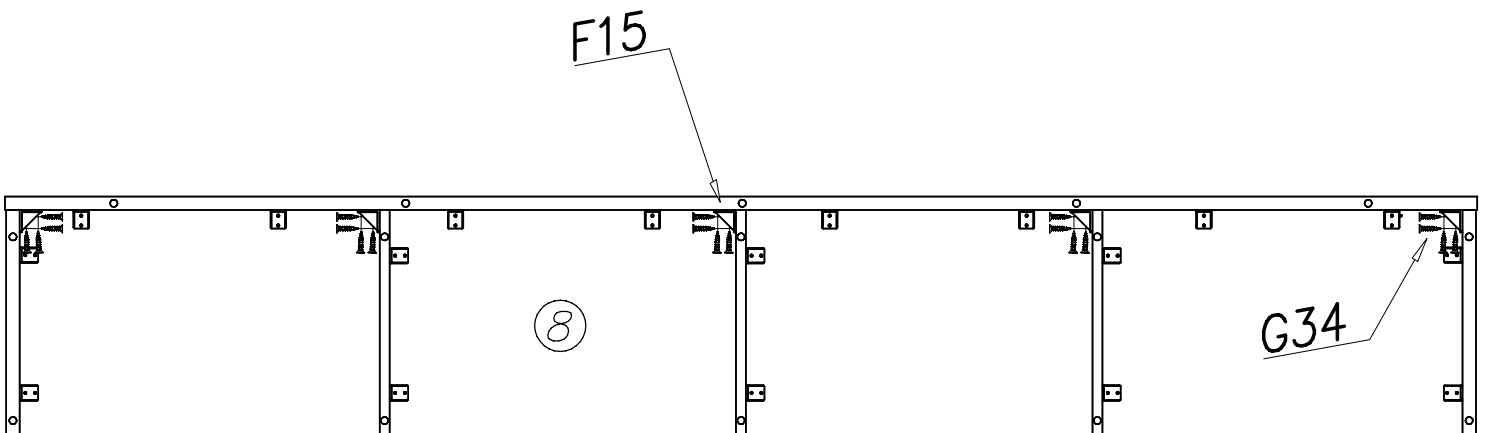
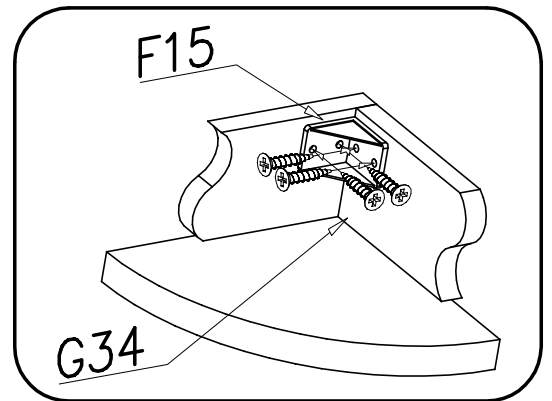
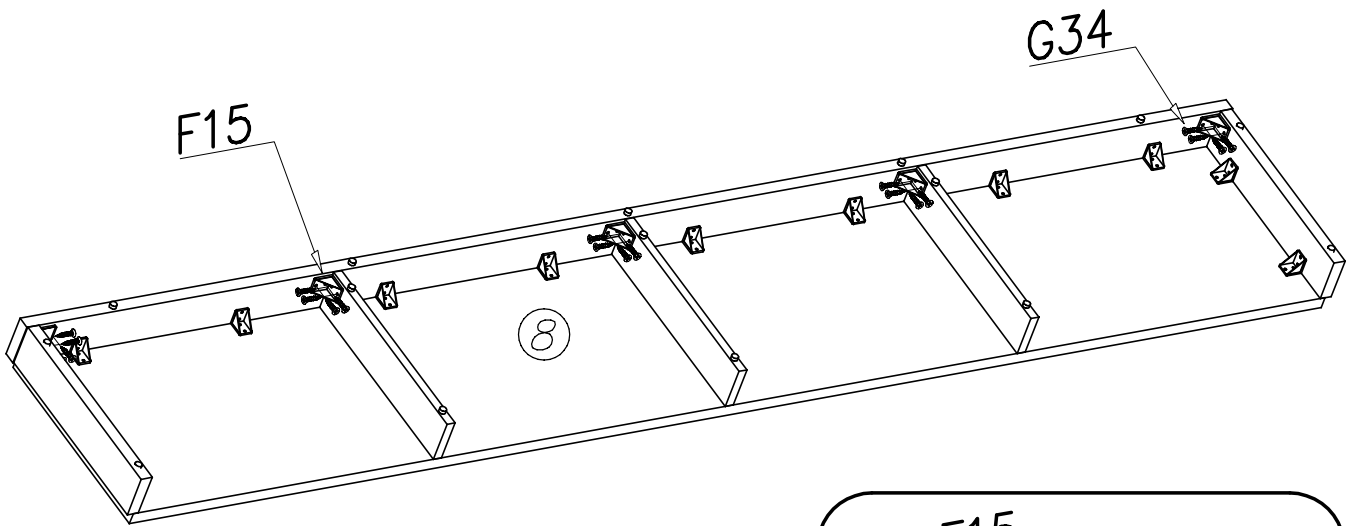
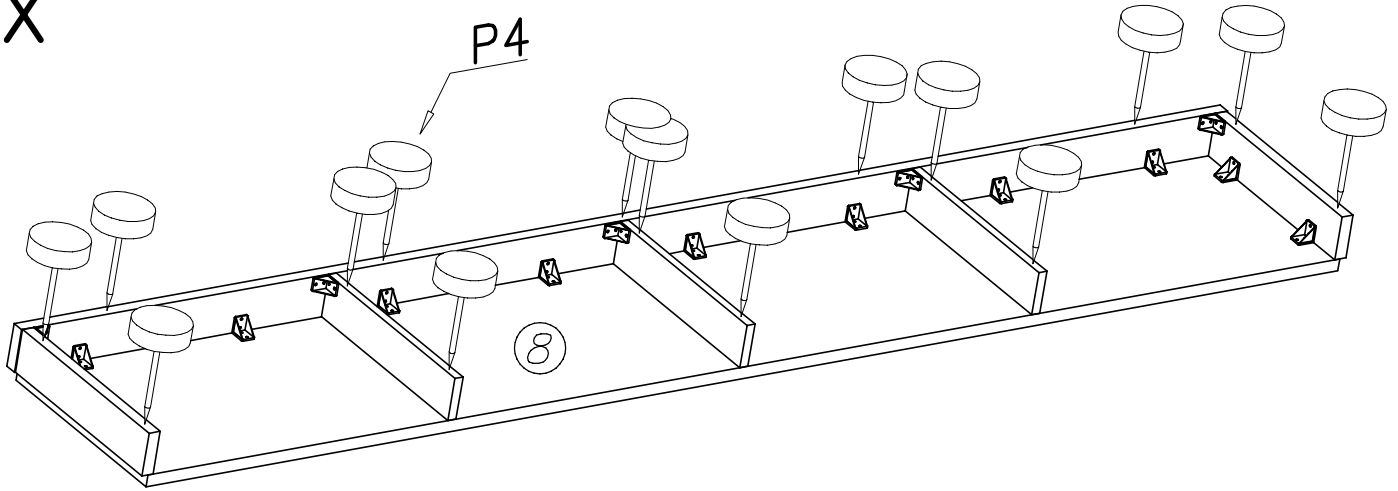



X

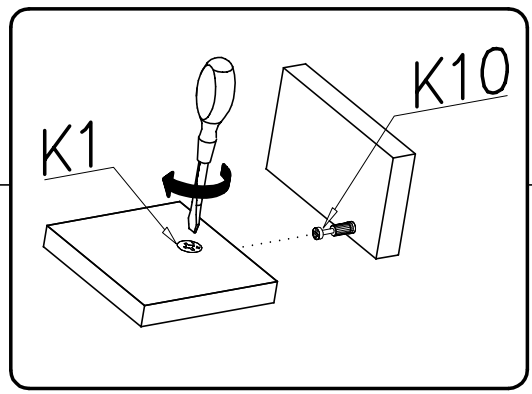
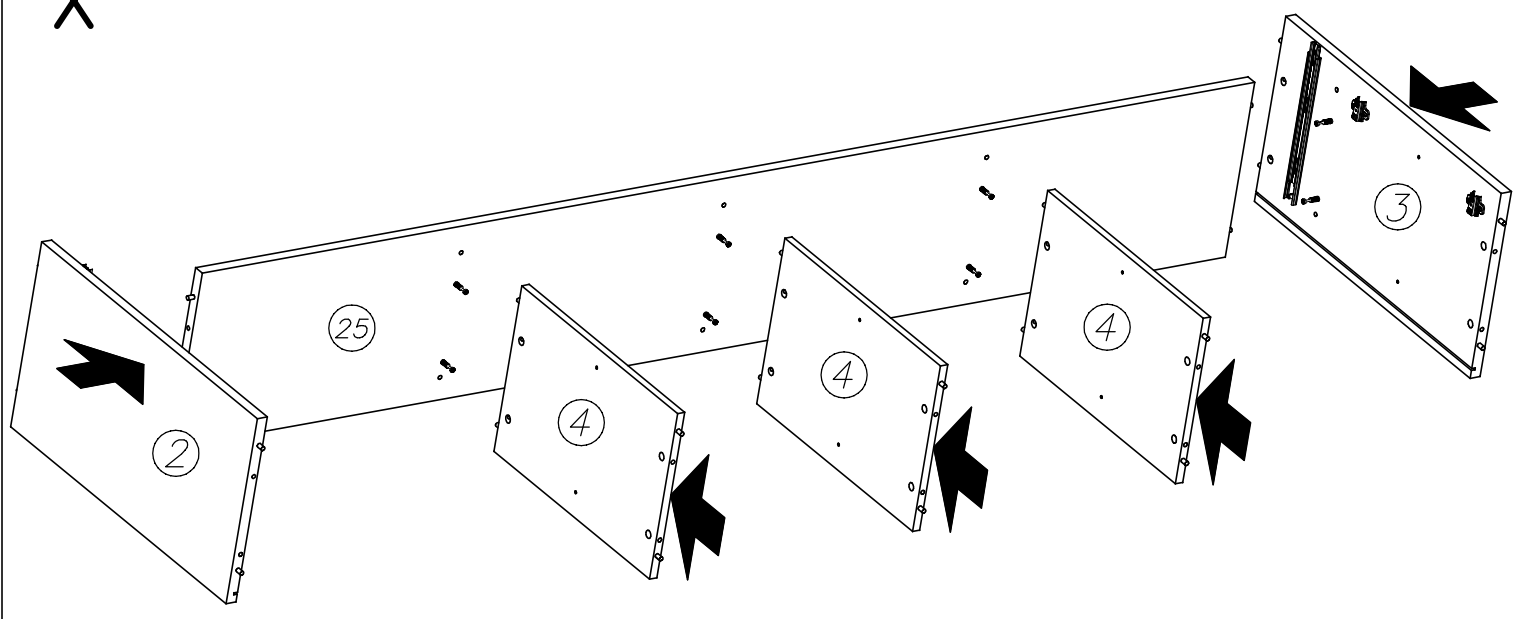

XI

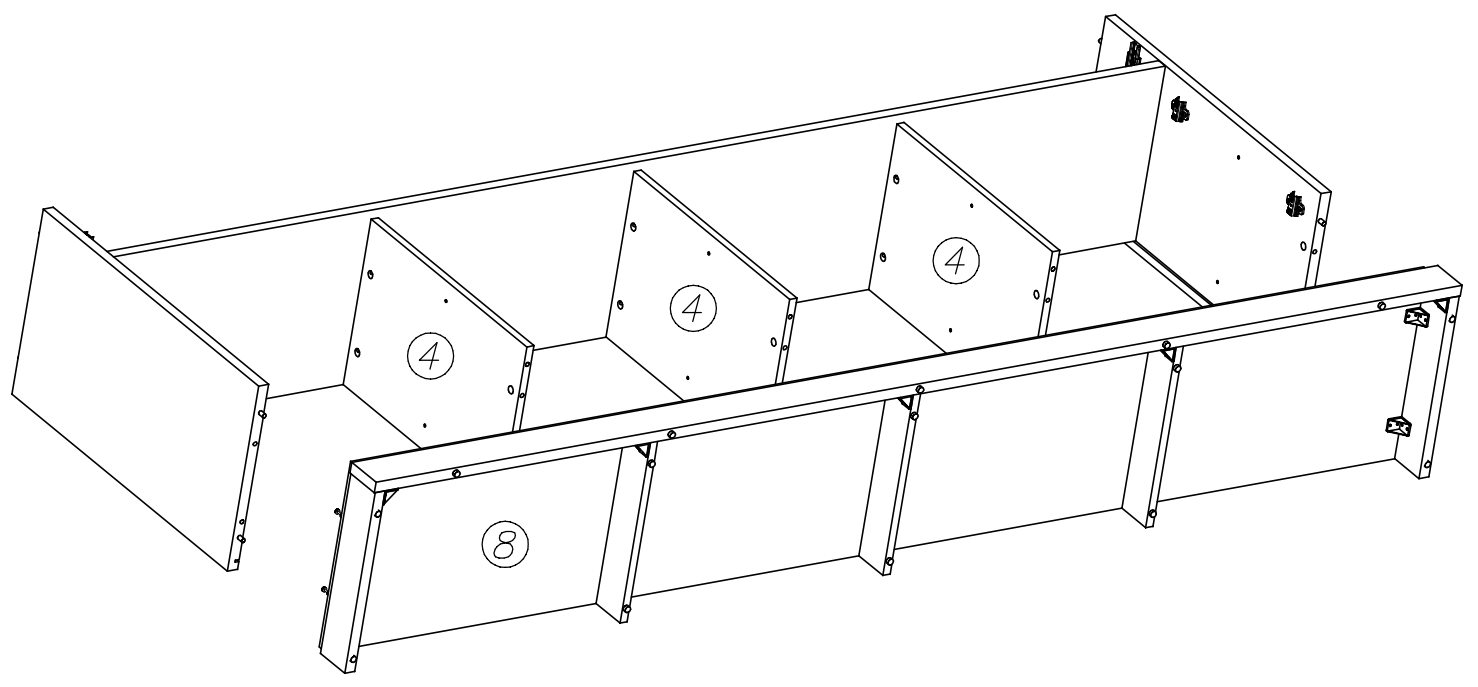

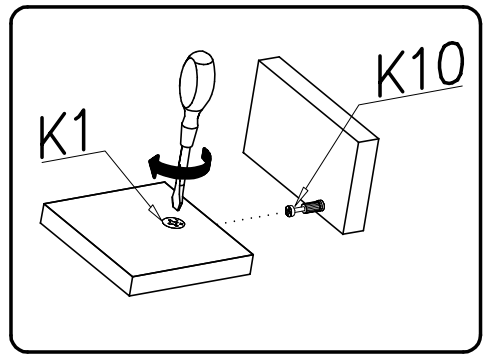

XII

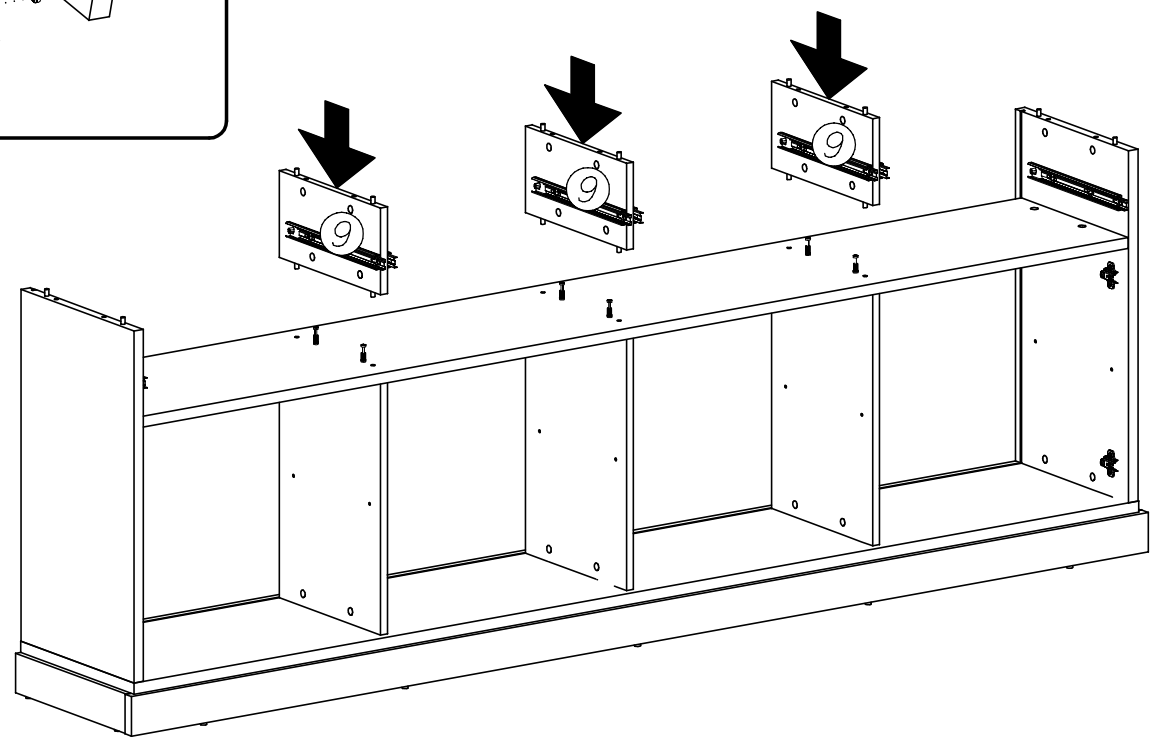
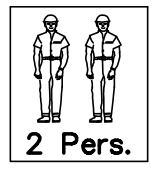

XIII

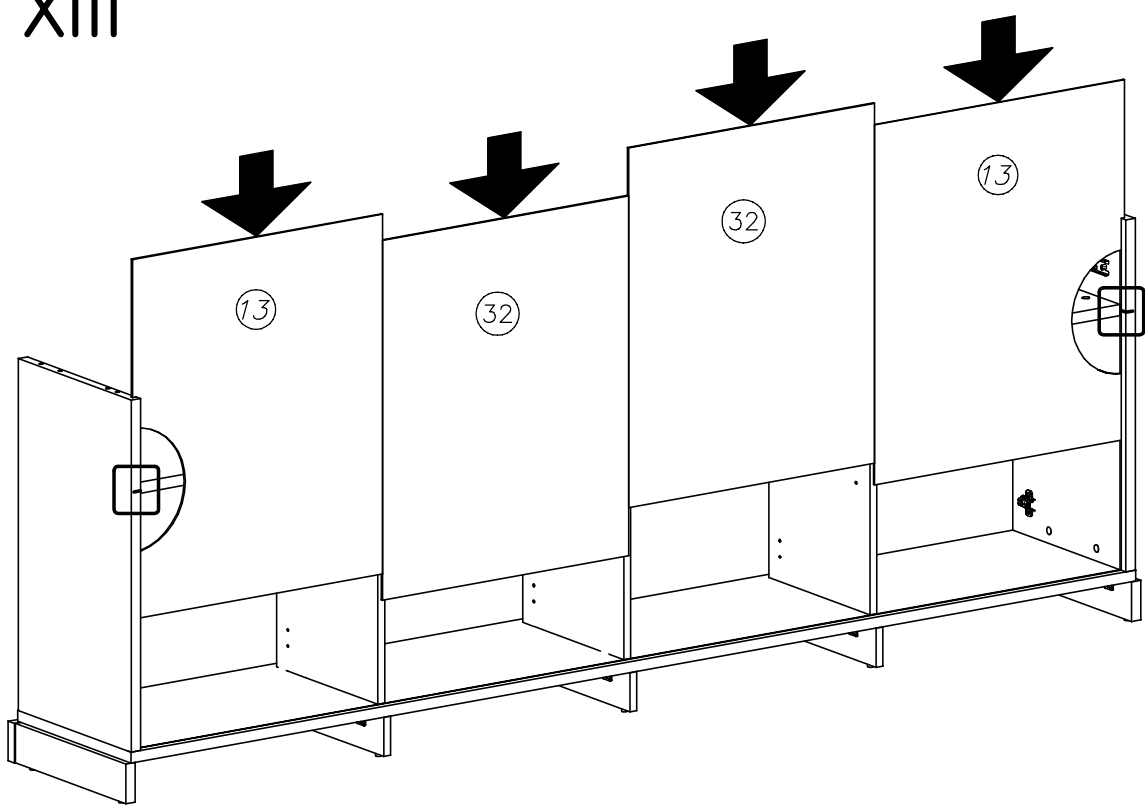
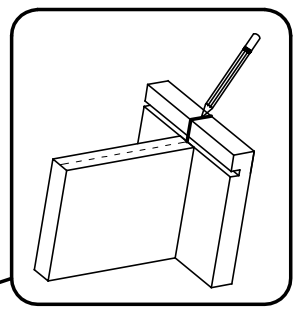



XIV

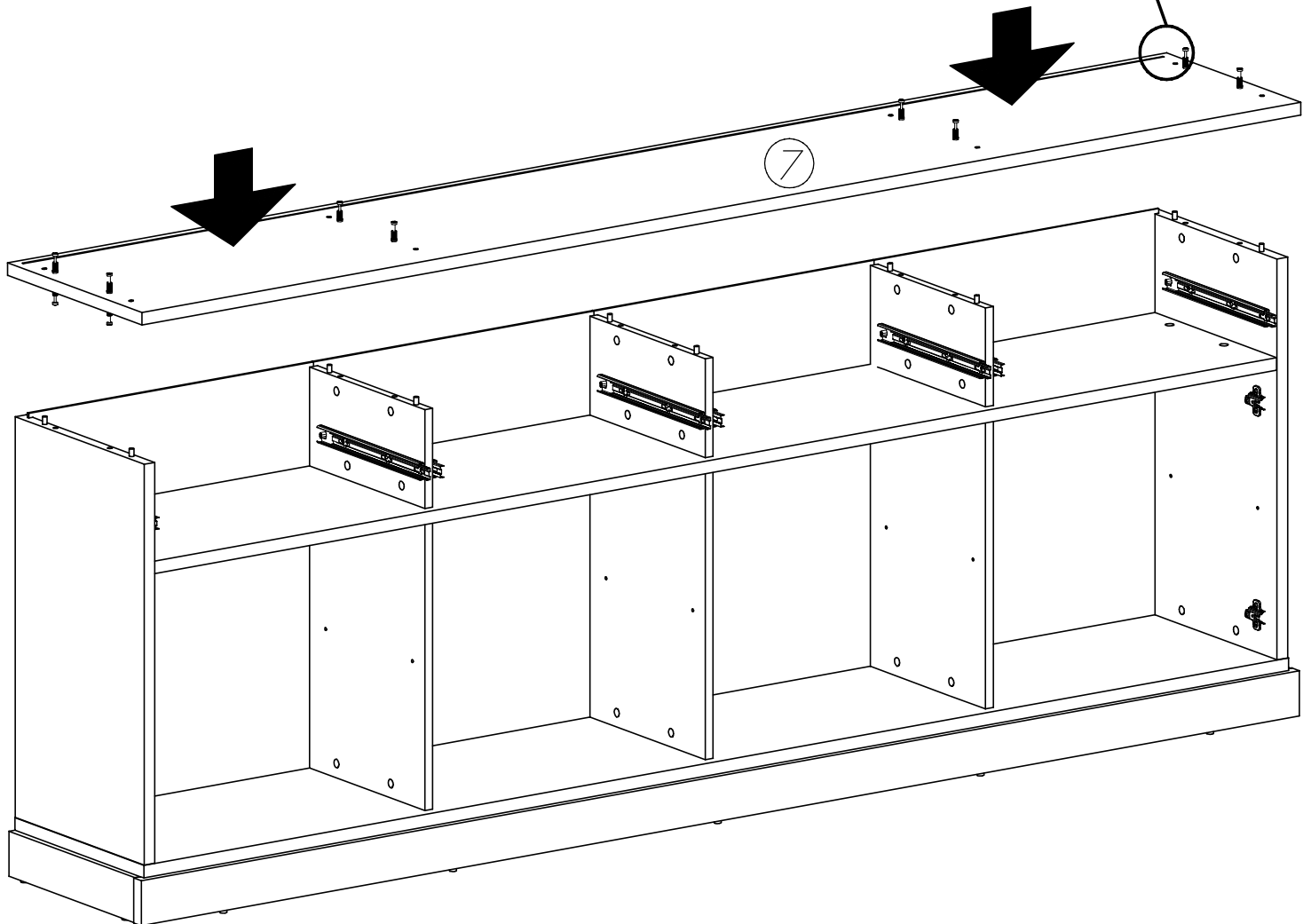
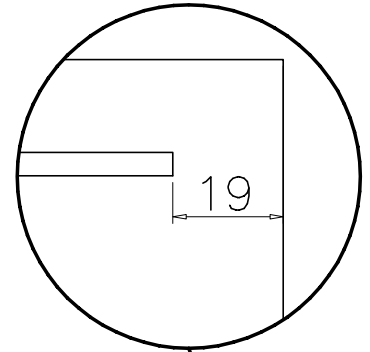
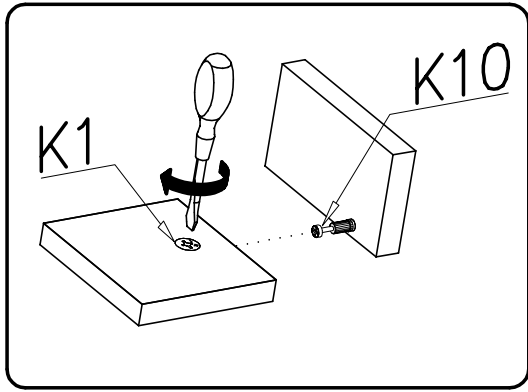

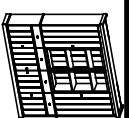

XV

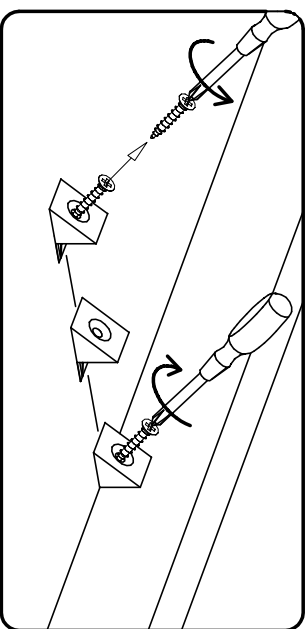
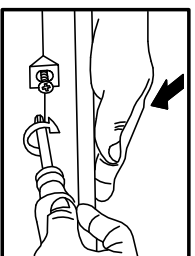
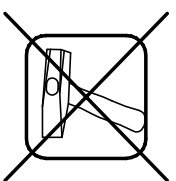
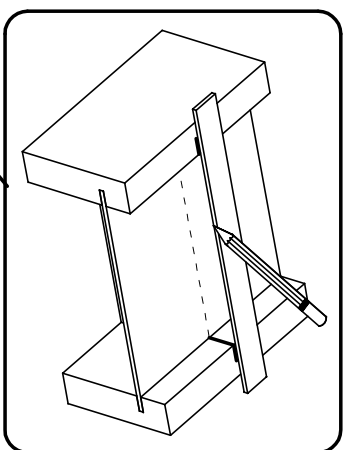
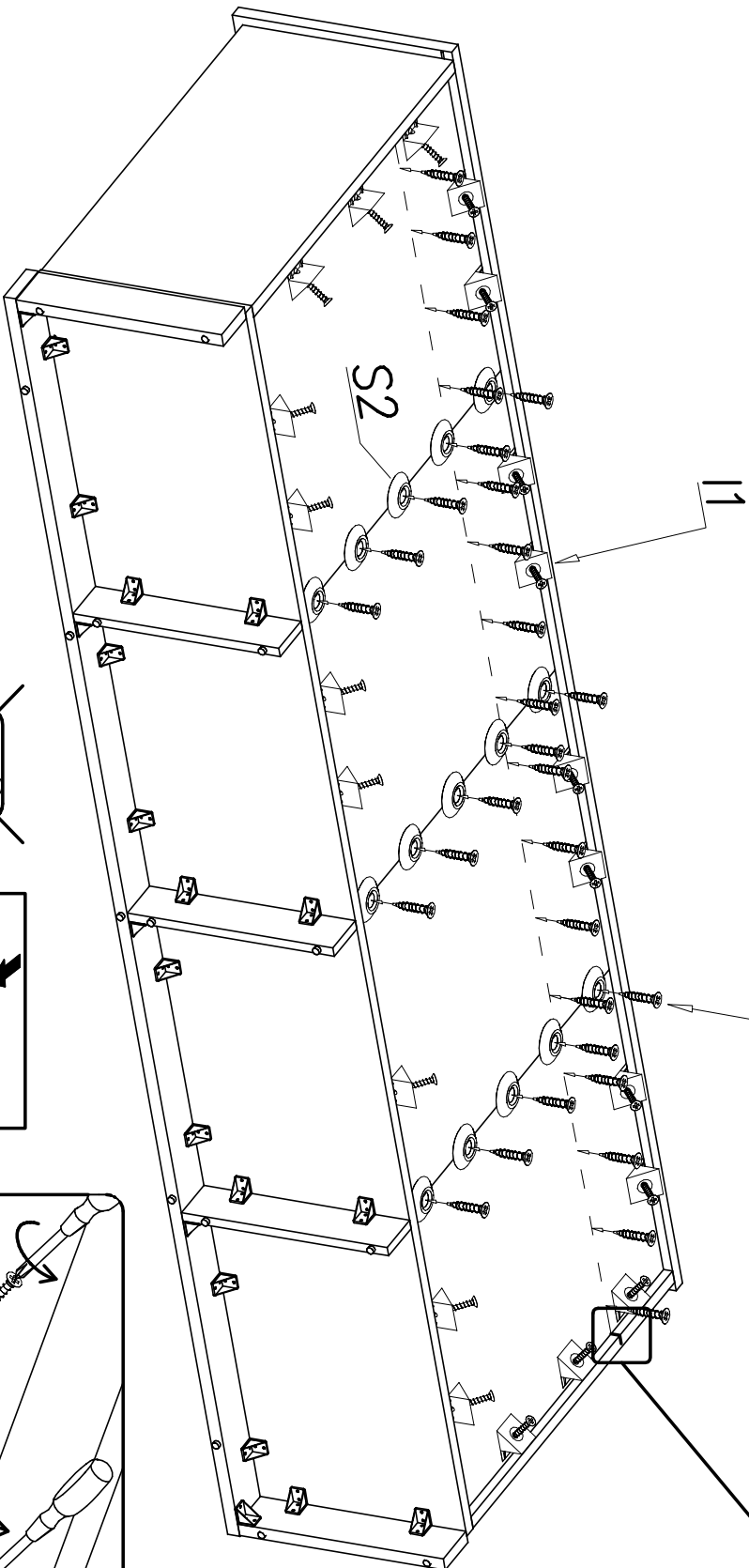
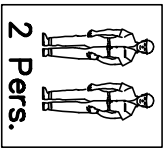
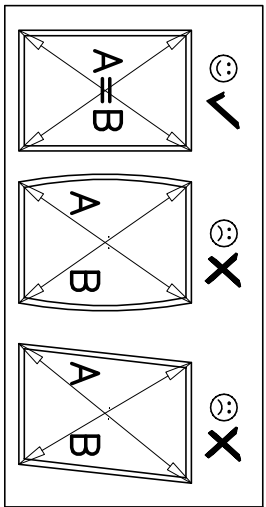

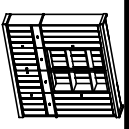

XVI

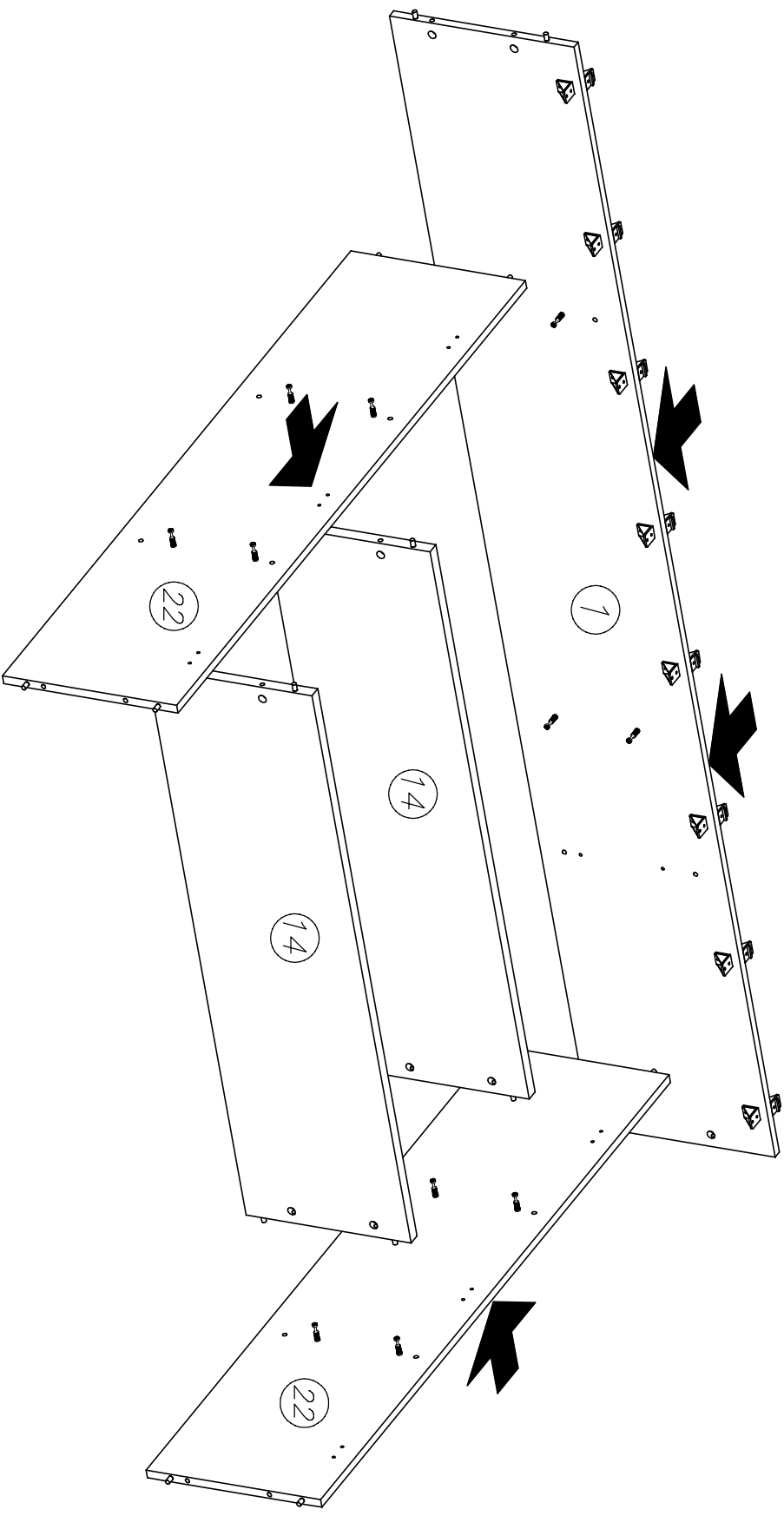
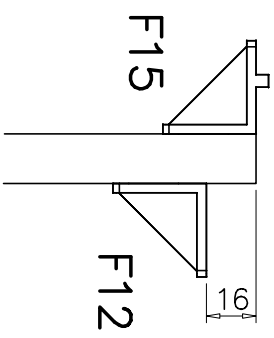
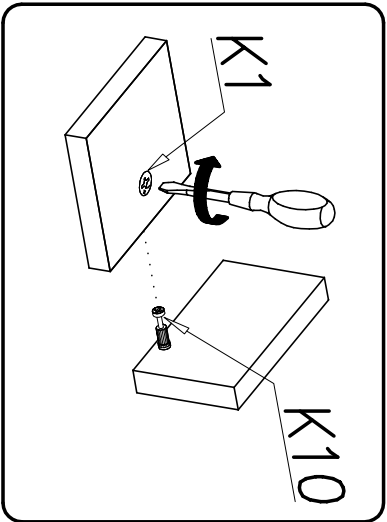

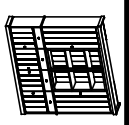

XVII

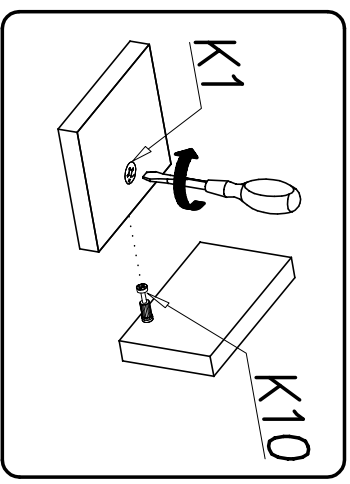
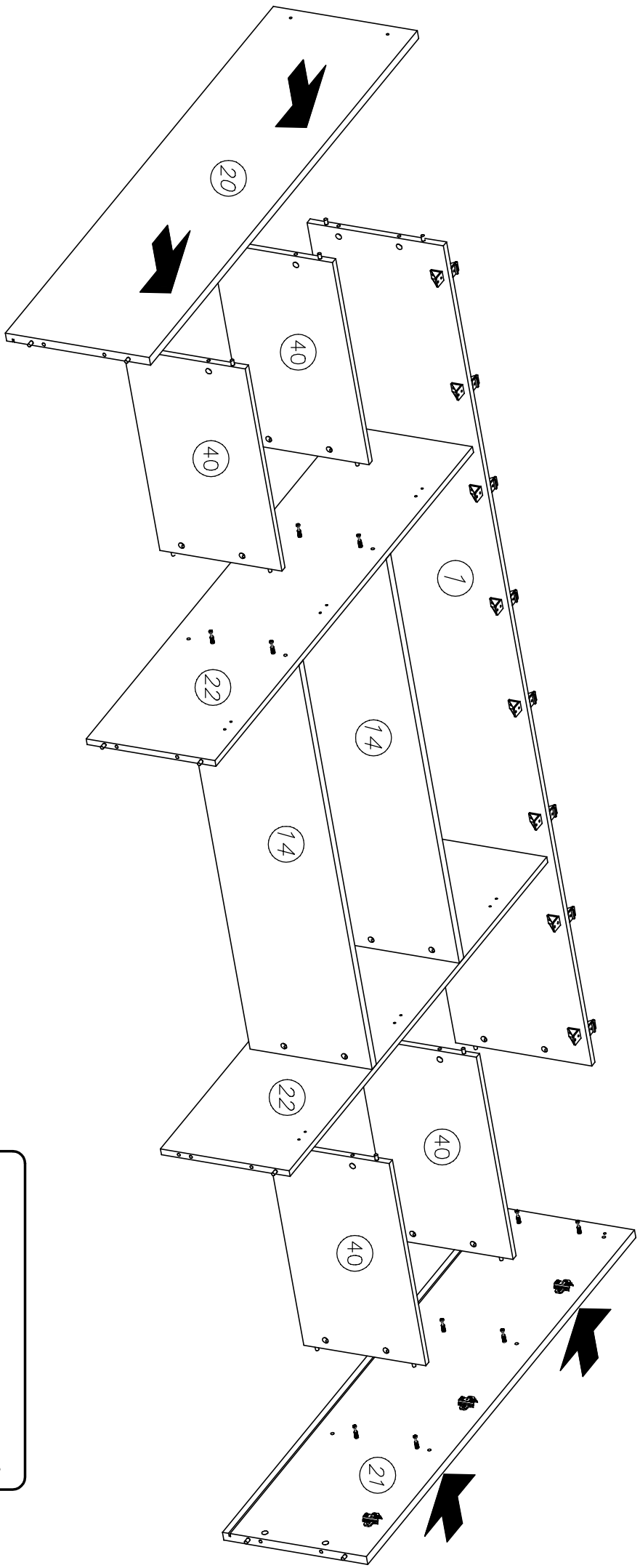



XVIII

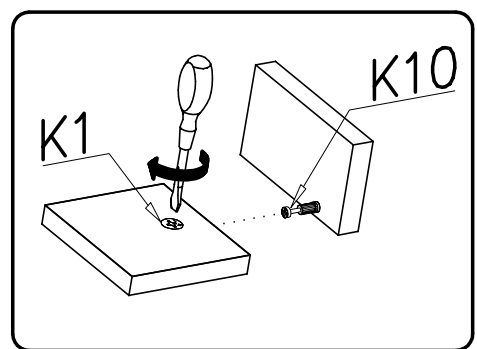
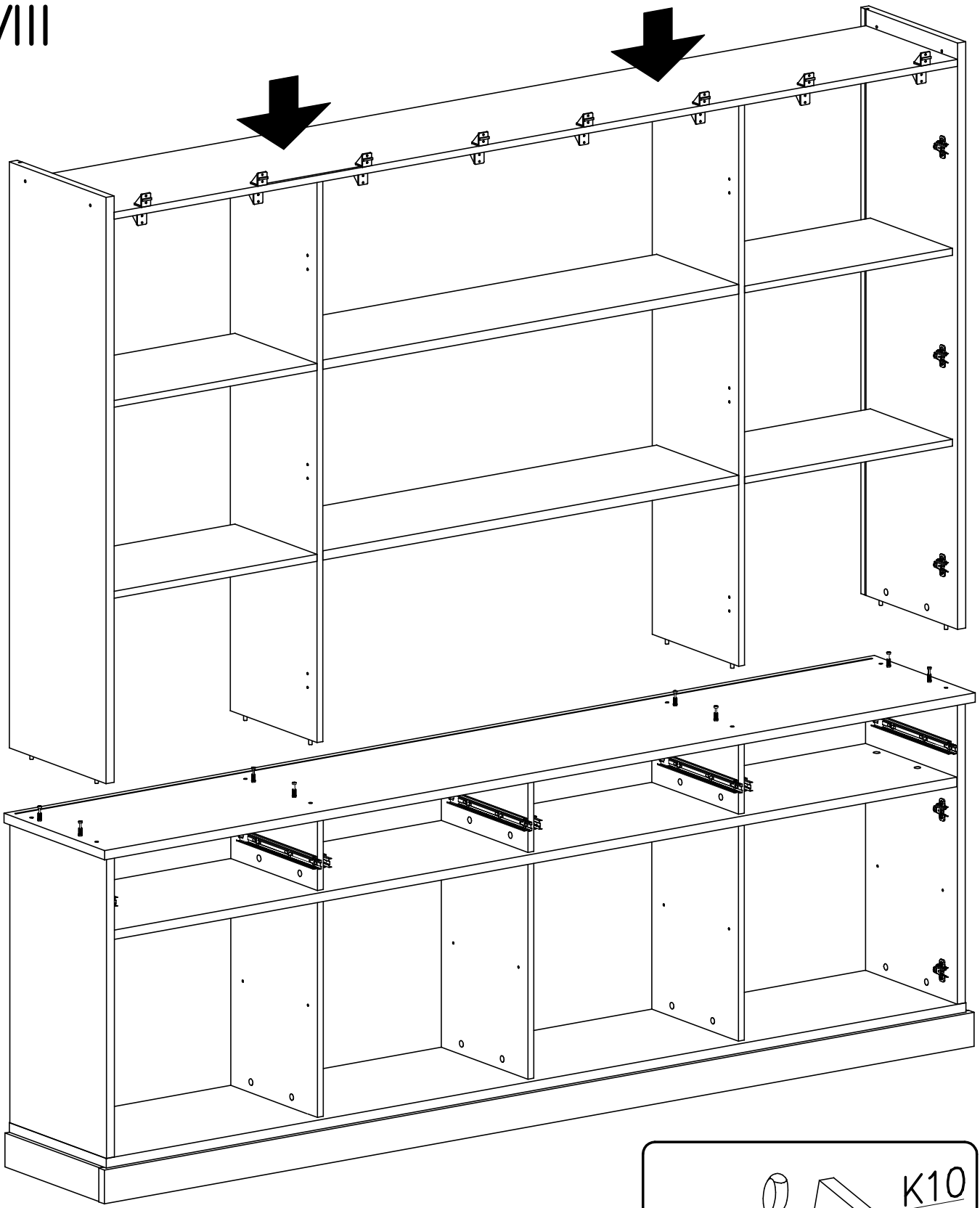



XIX

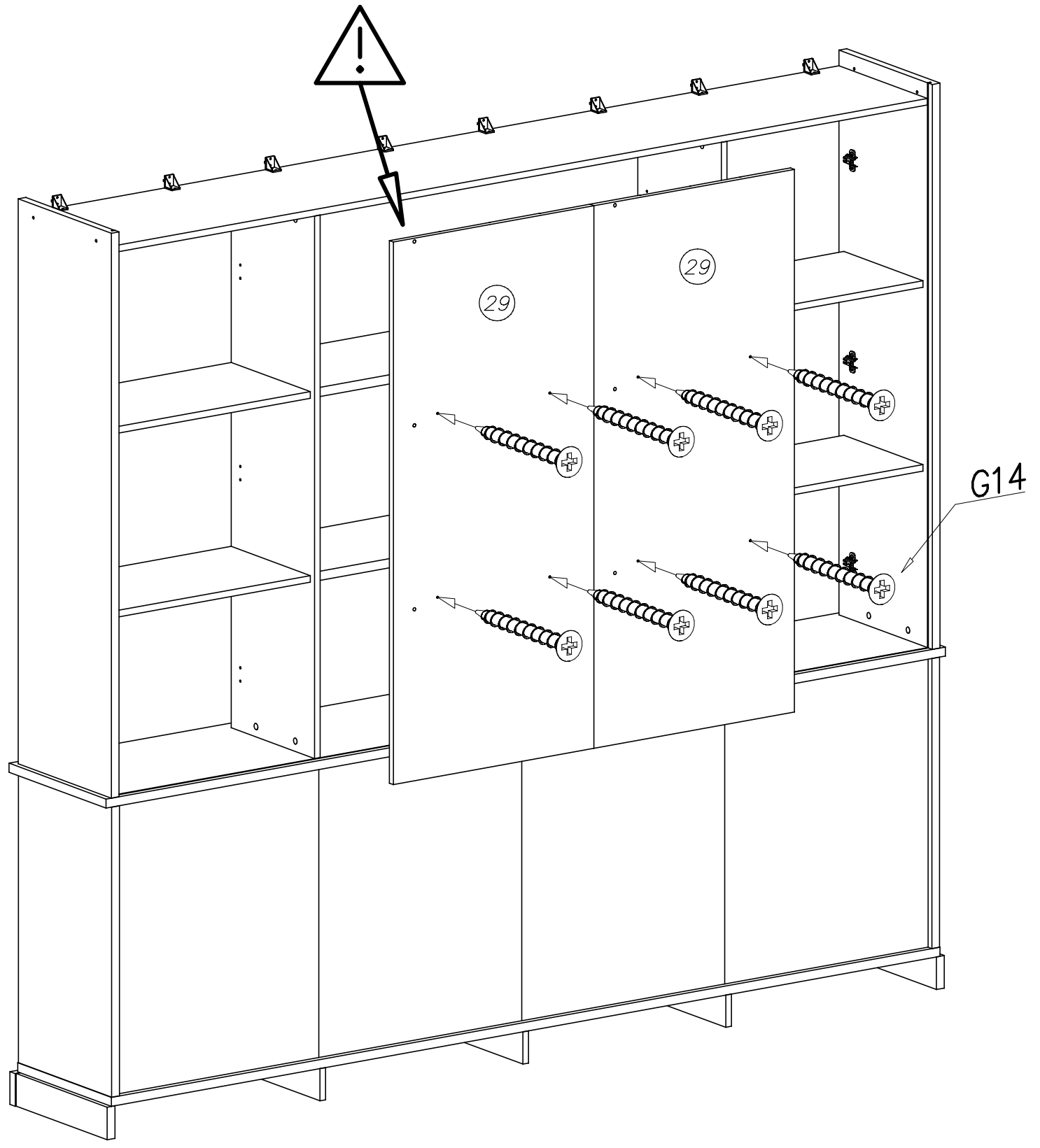



XX

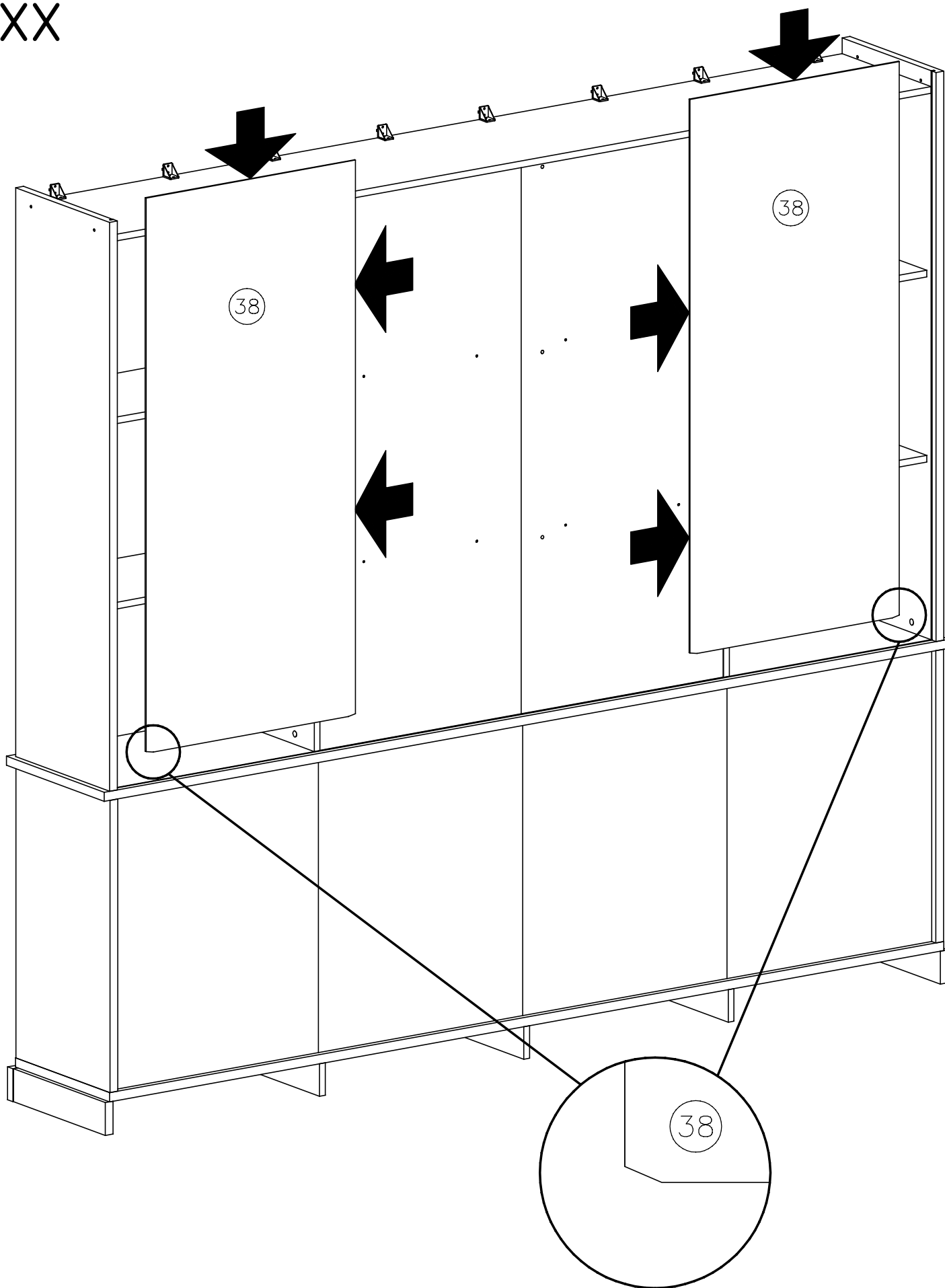



XXI

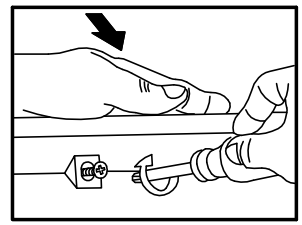
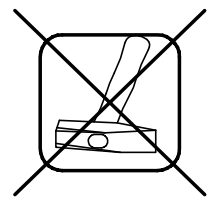
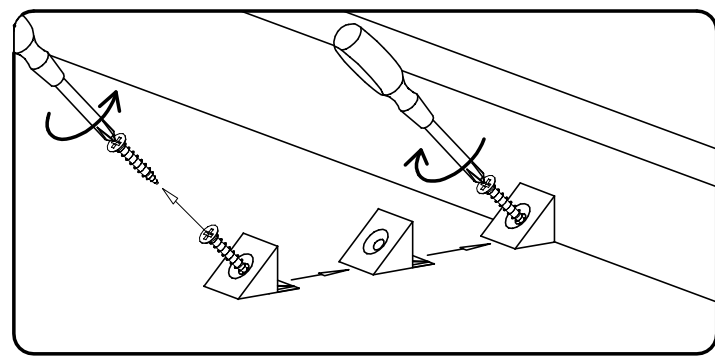
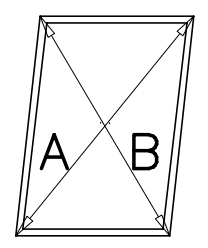
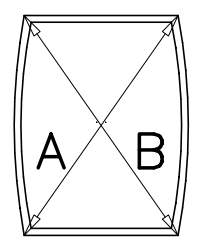
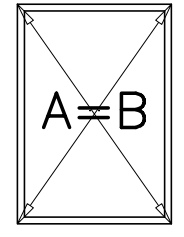
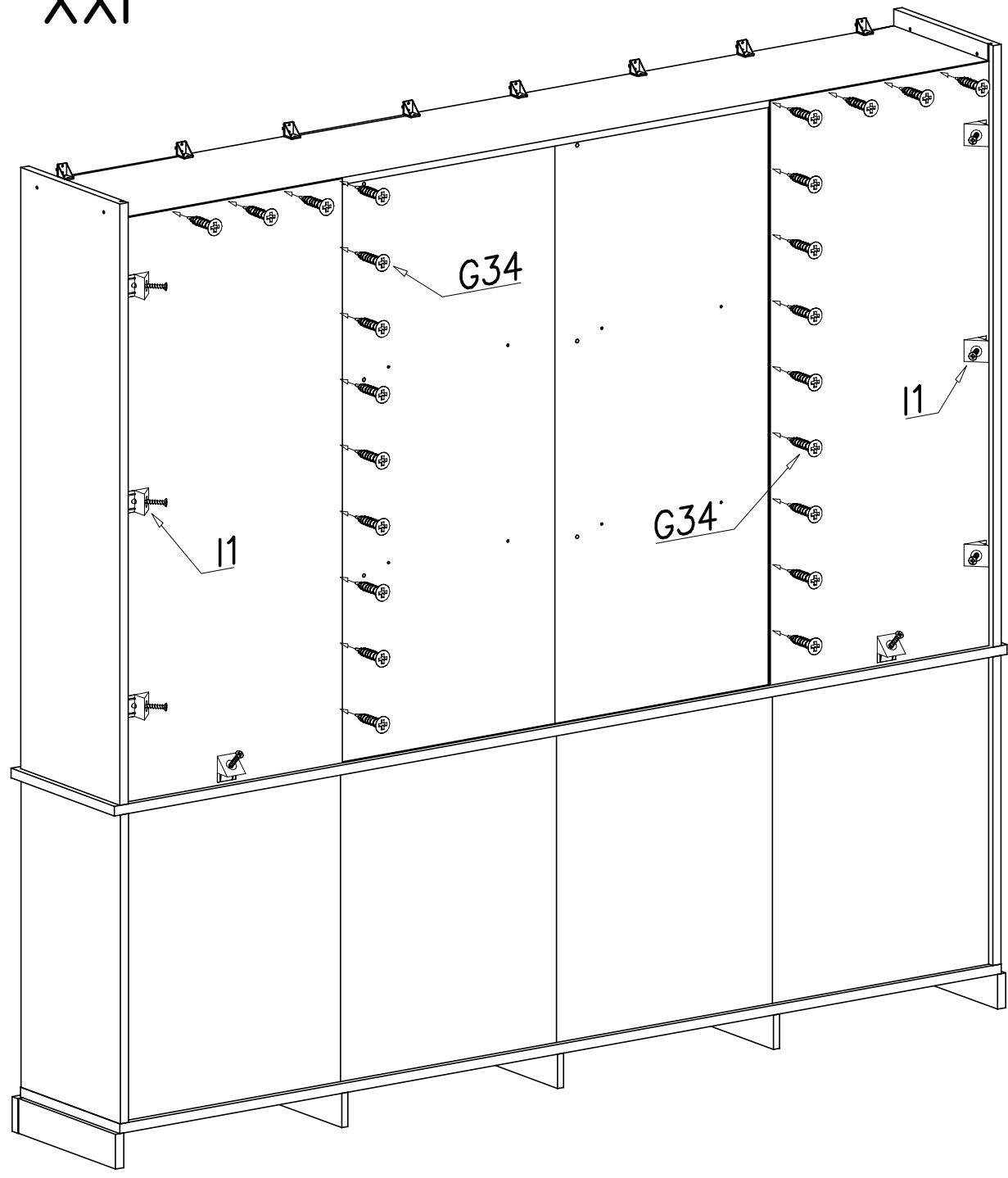



XXII

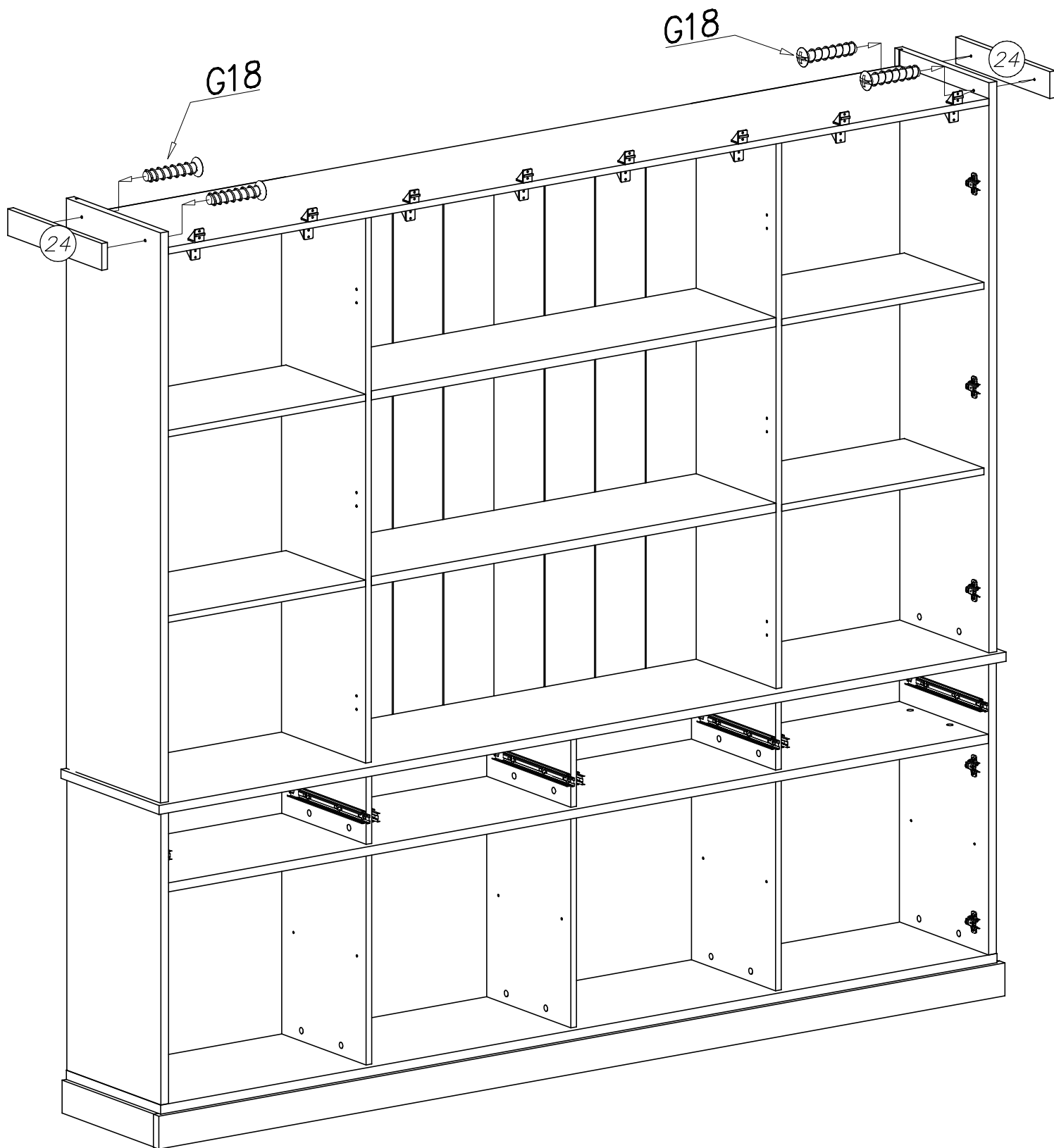



XXIII

1.

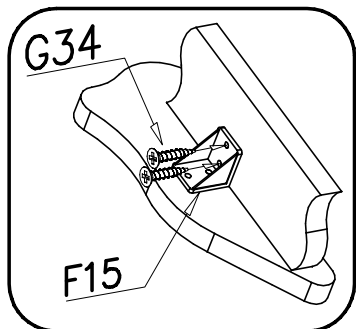

2.

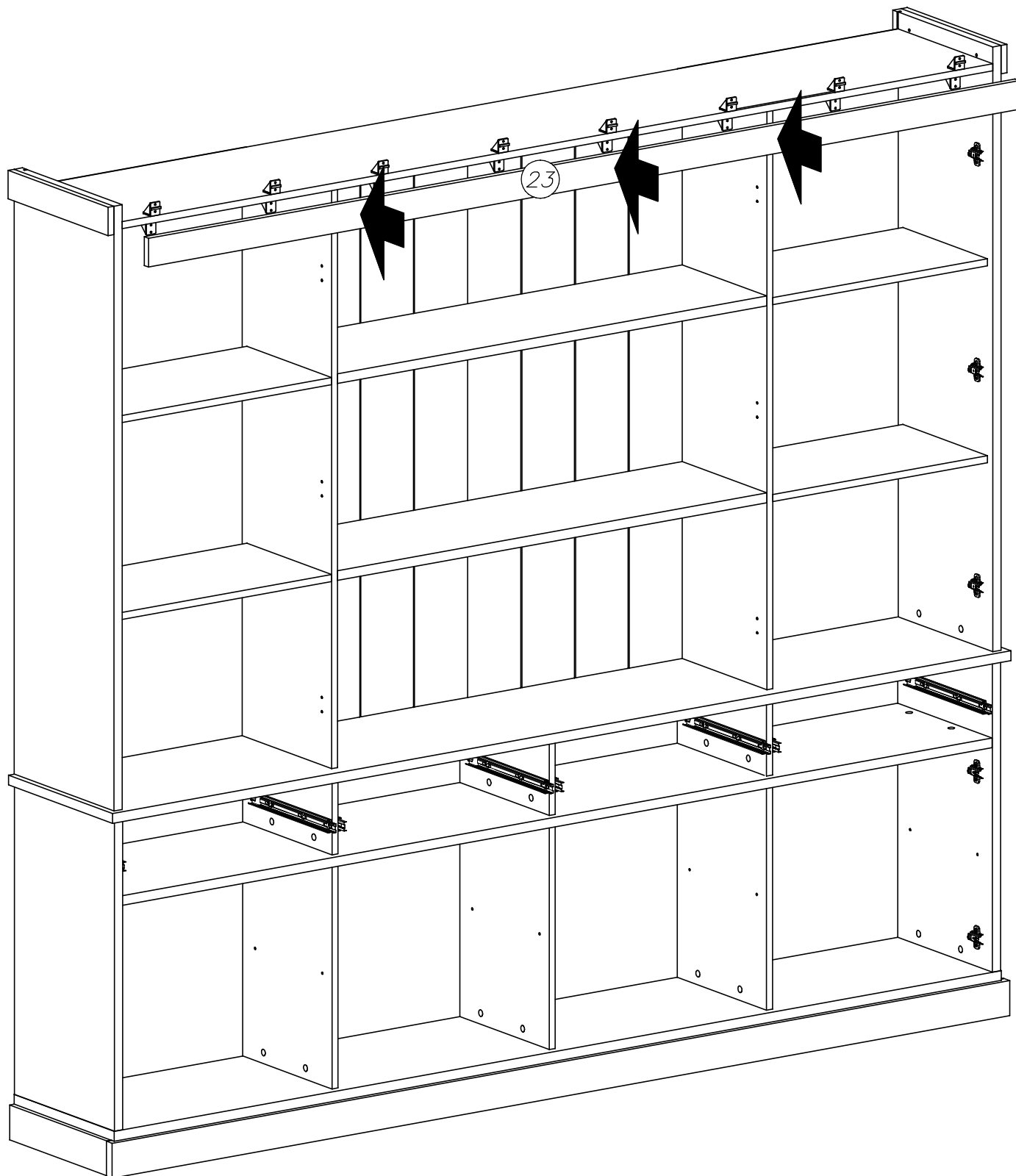
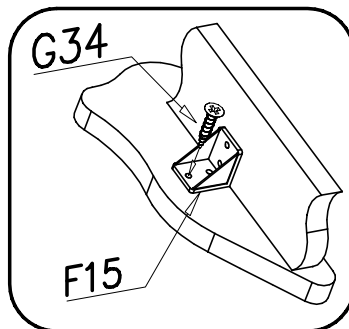



XXIV

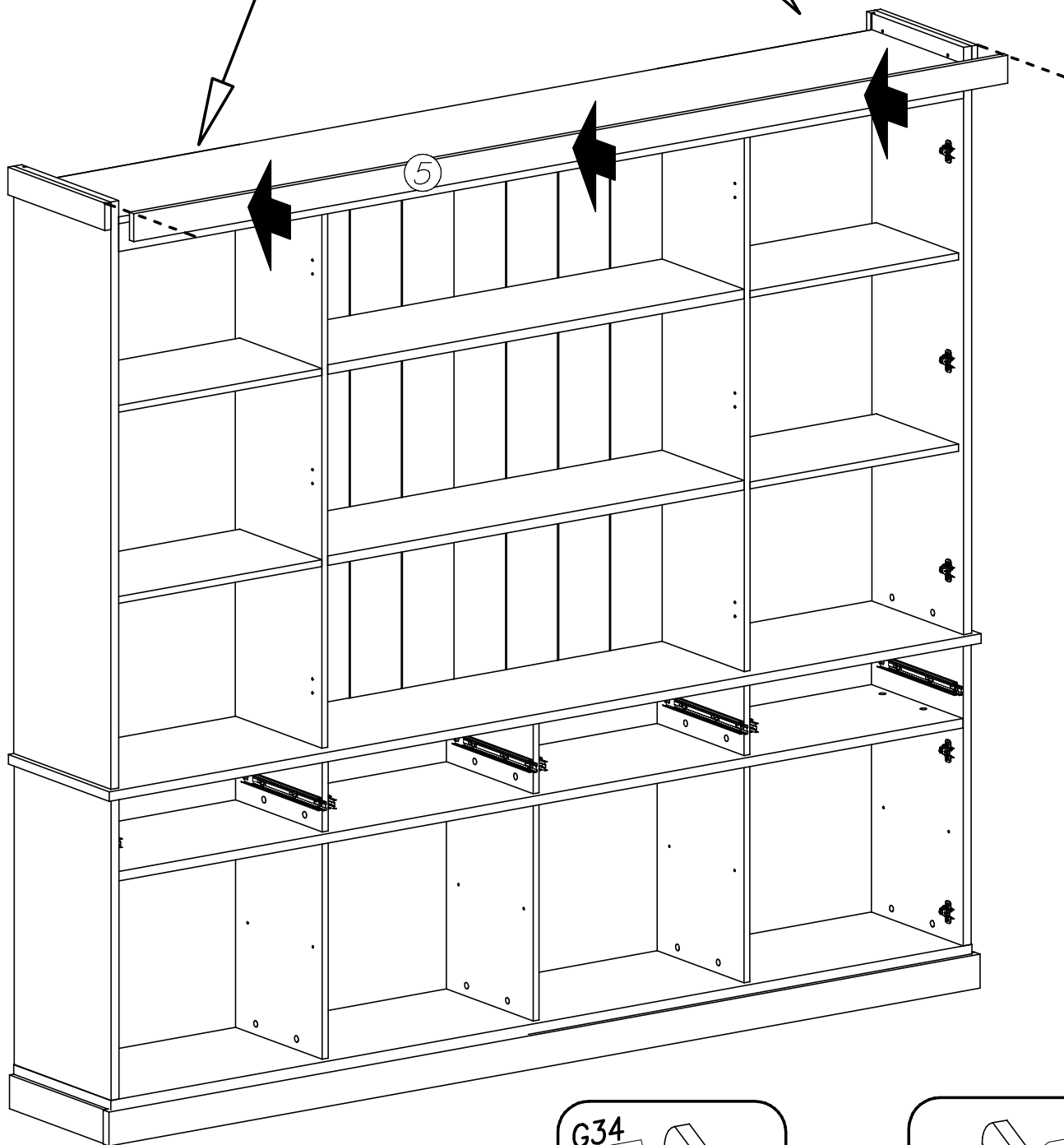
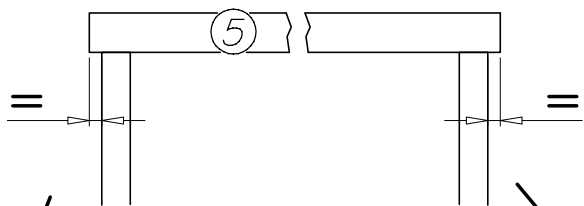

1.

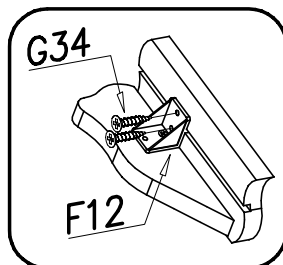

2.

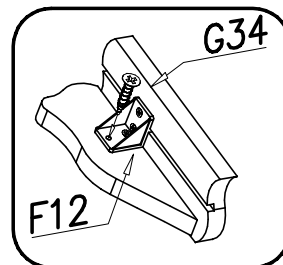



XXV

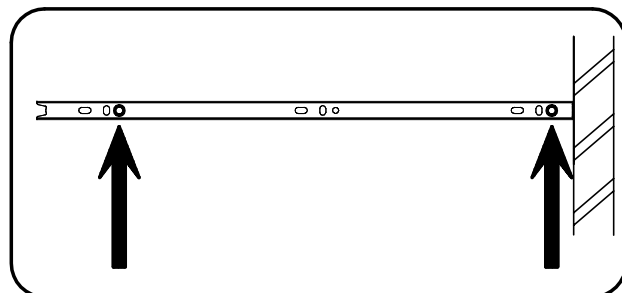
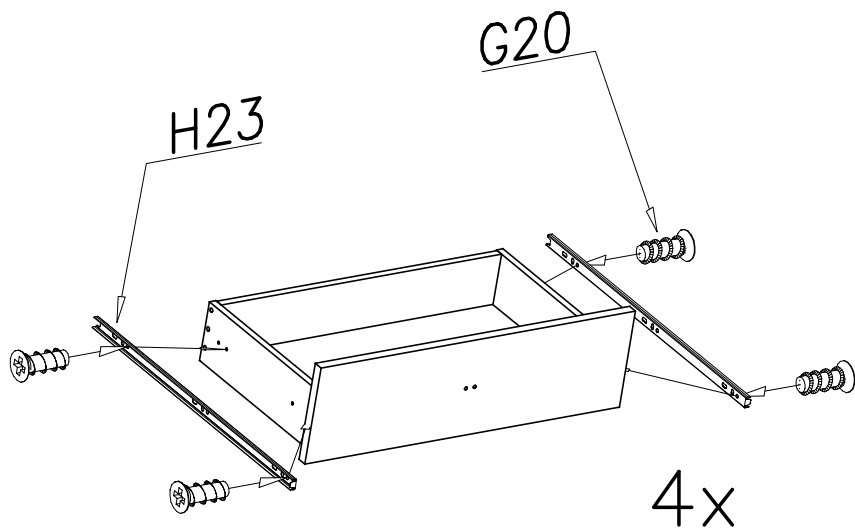
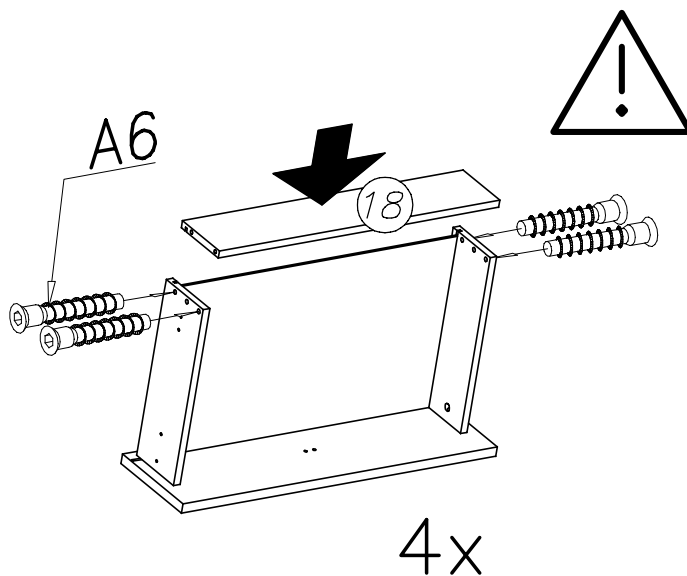
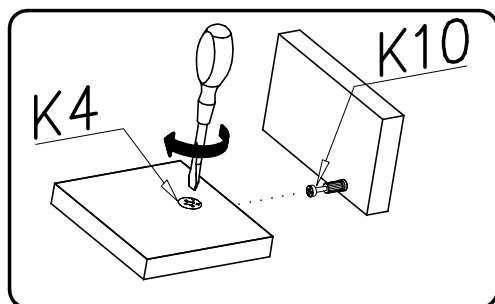
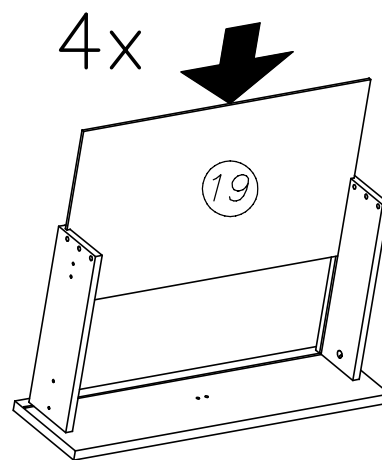
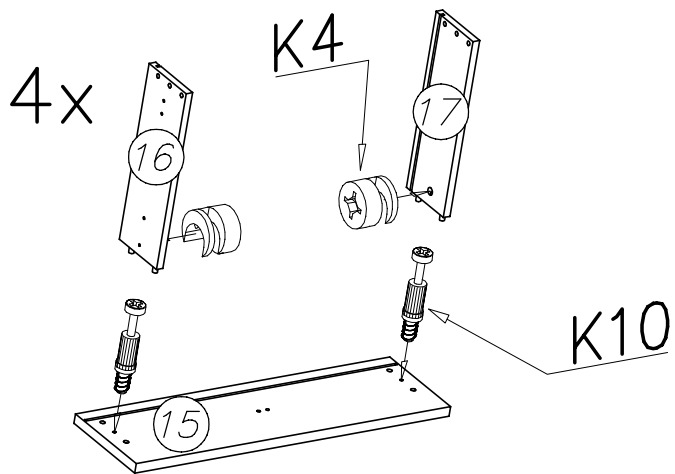



XXVI

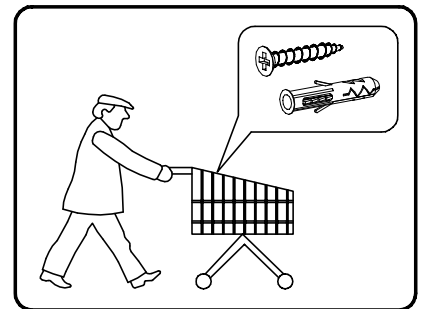
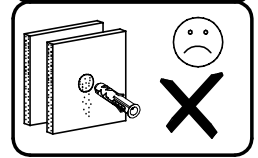
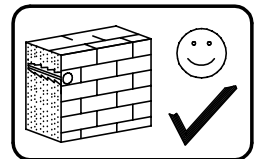
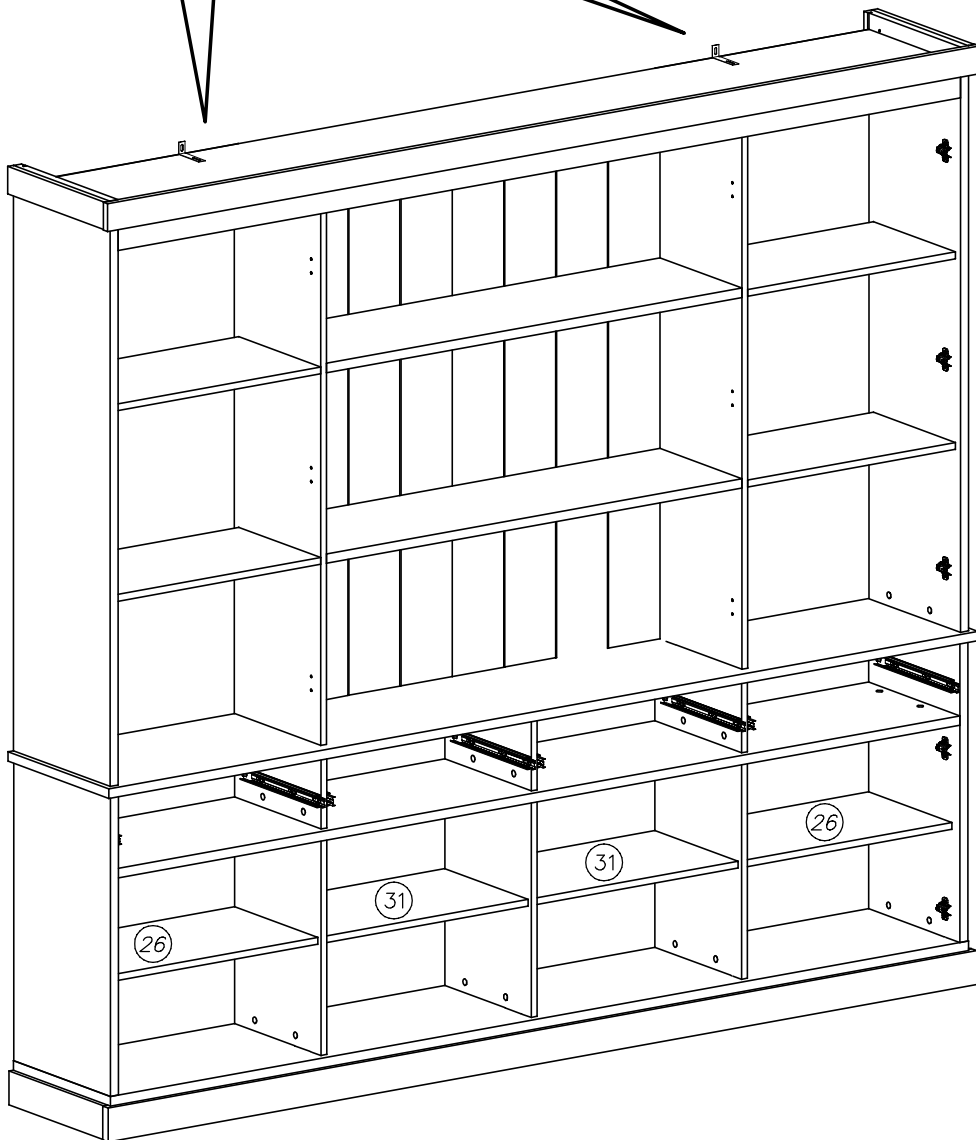
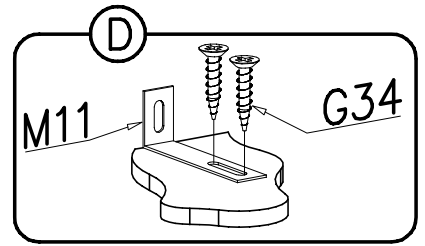
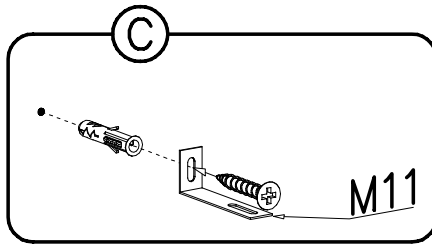
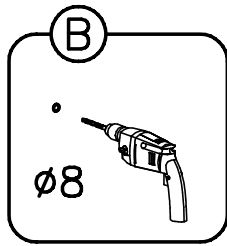
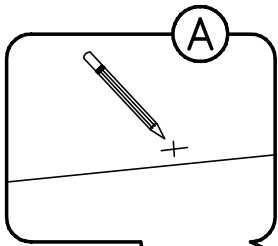

1

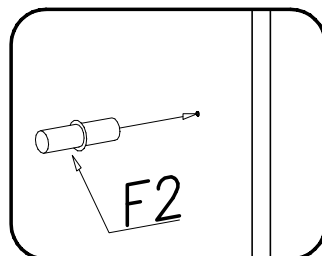

2

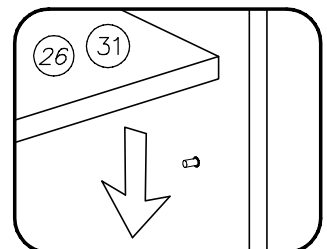



XXVII

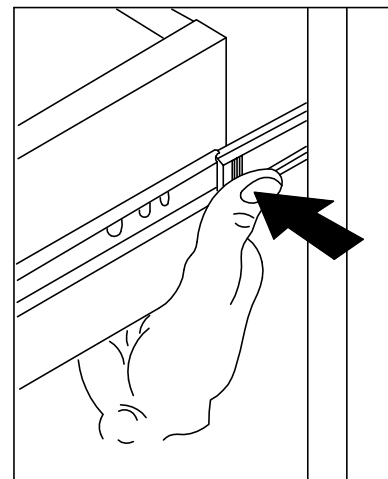
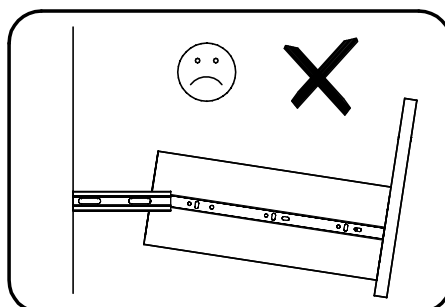
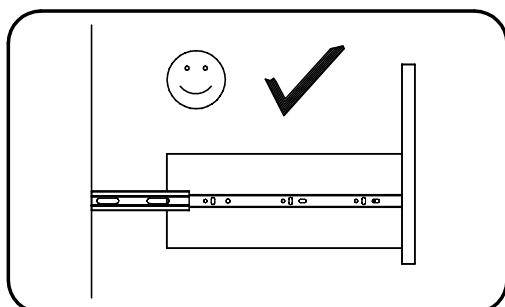
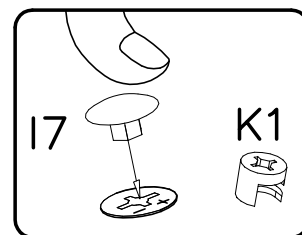
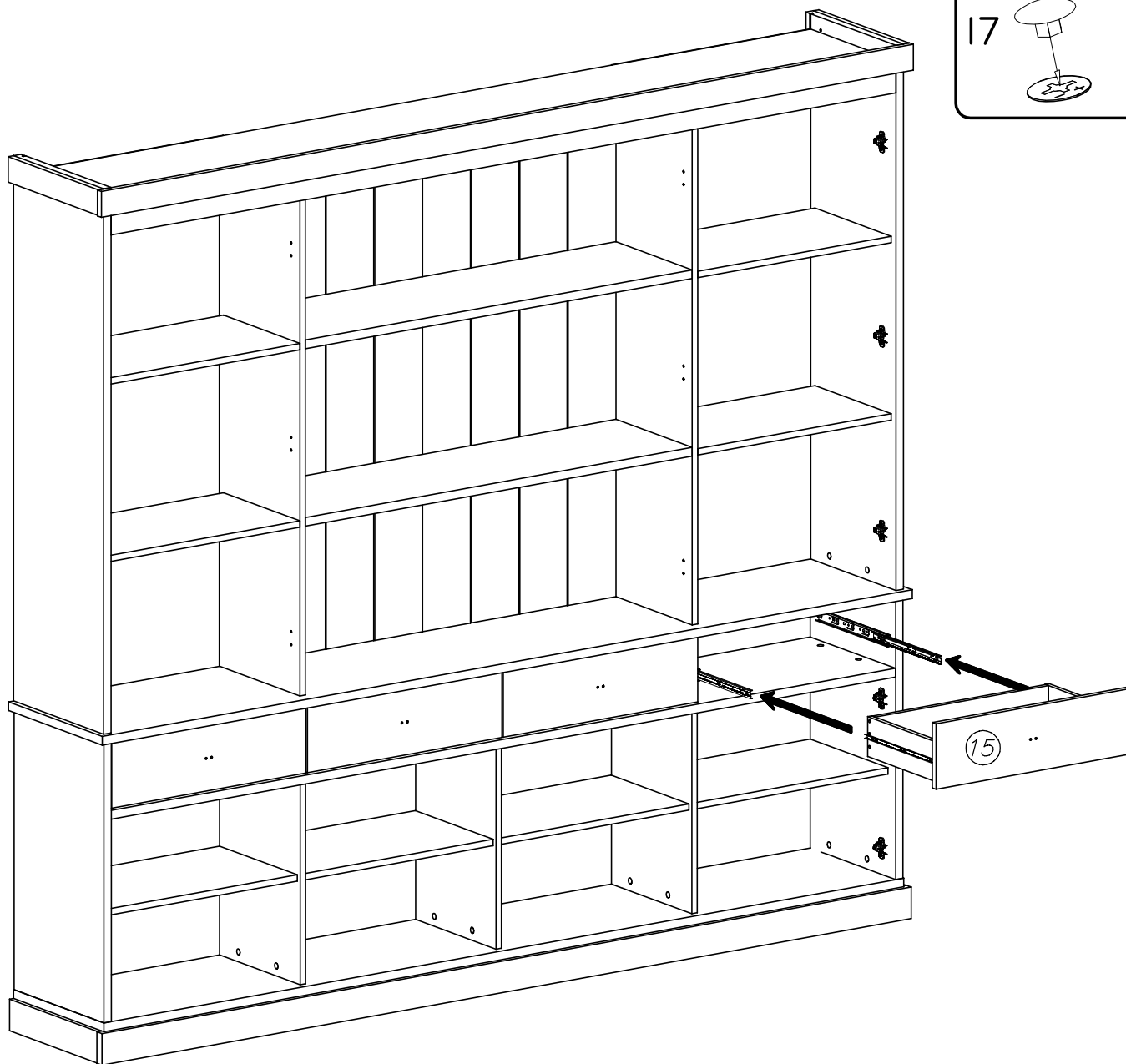



XXVIII

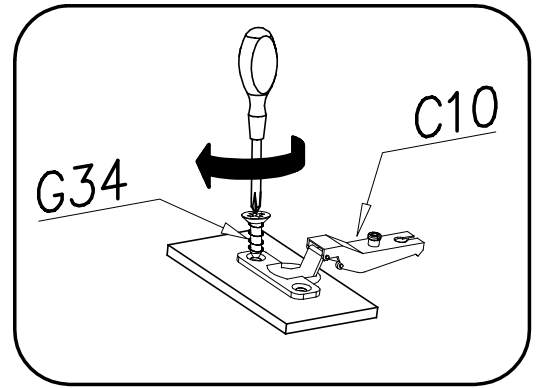
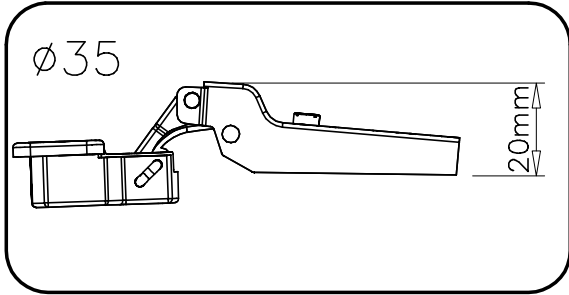
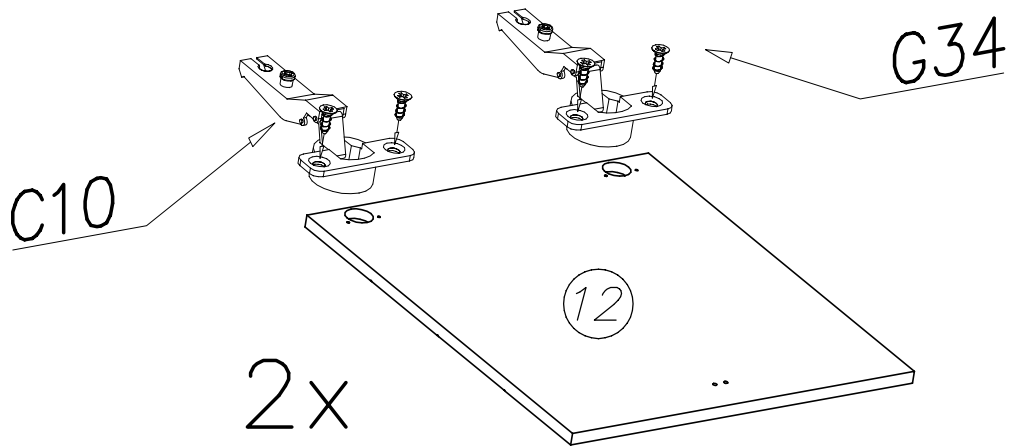

XXIX

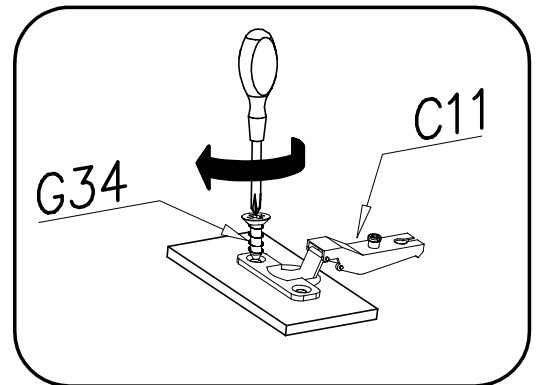
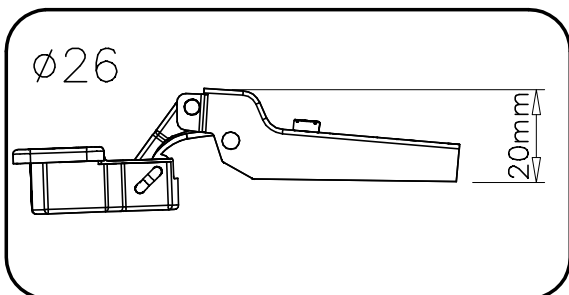
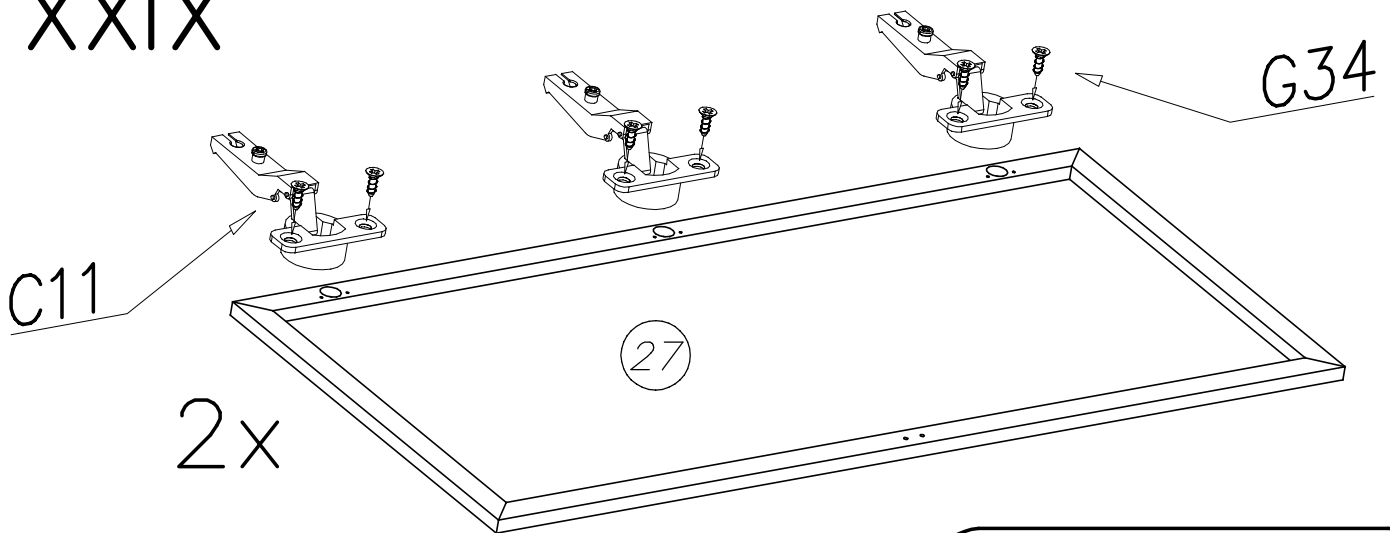



XXX

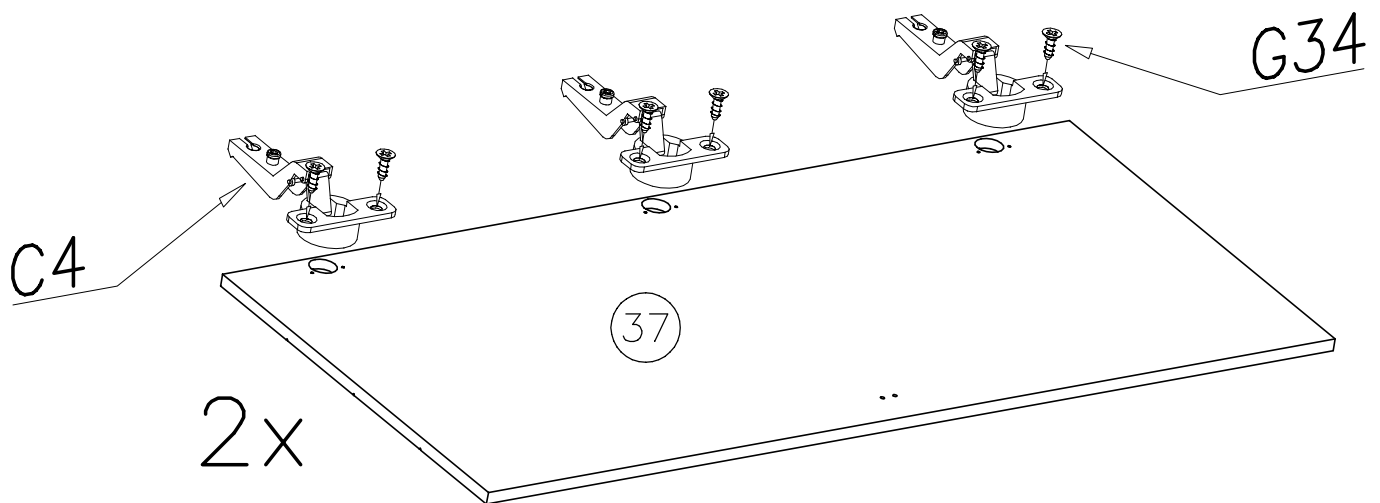
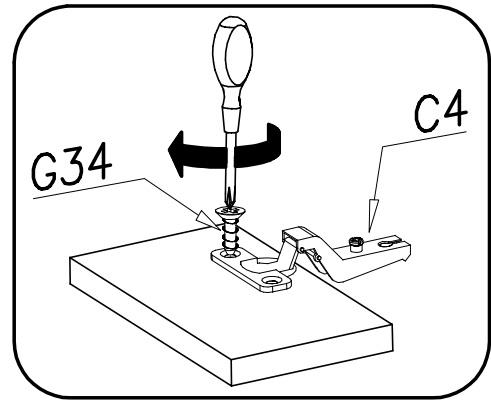
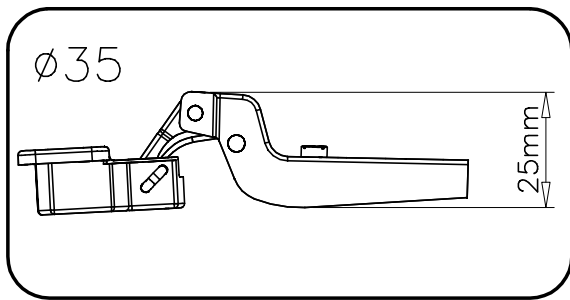
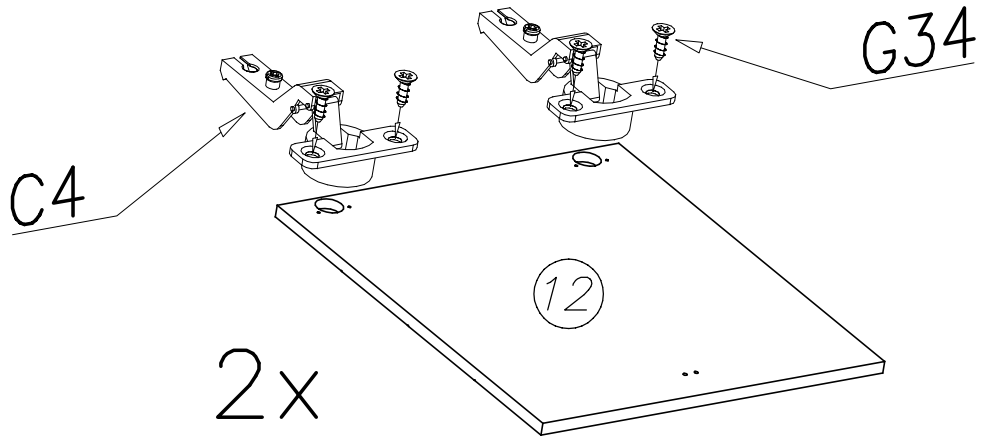



XXXI

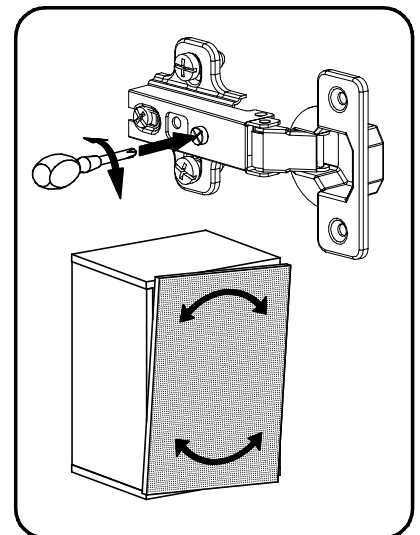
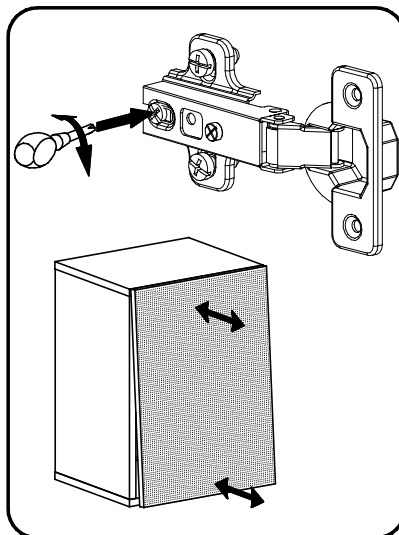
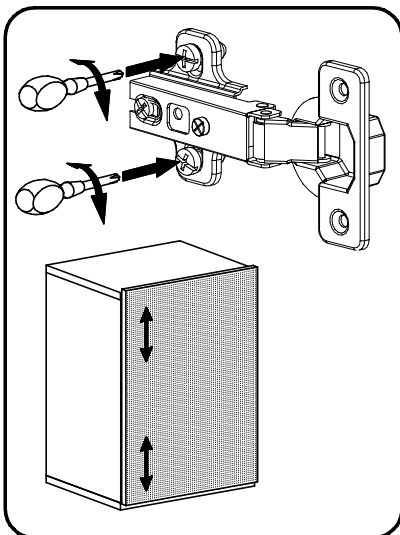
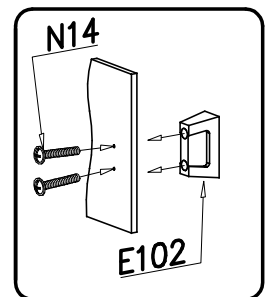
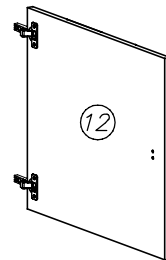
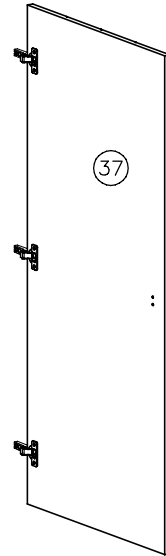
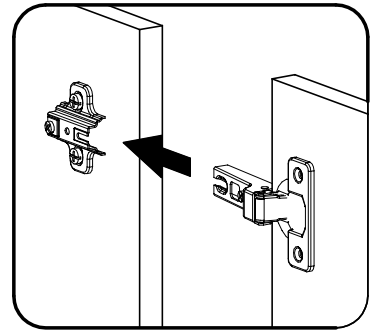
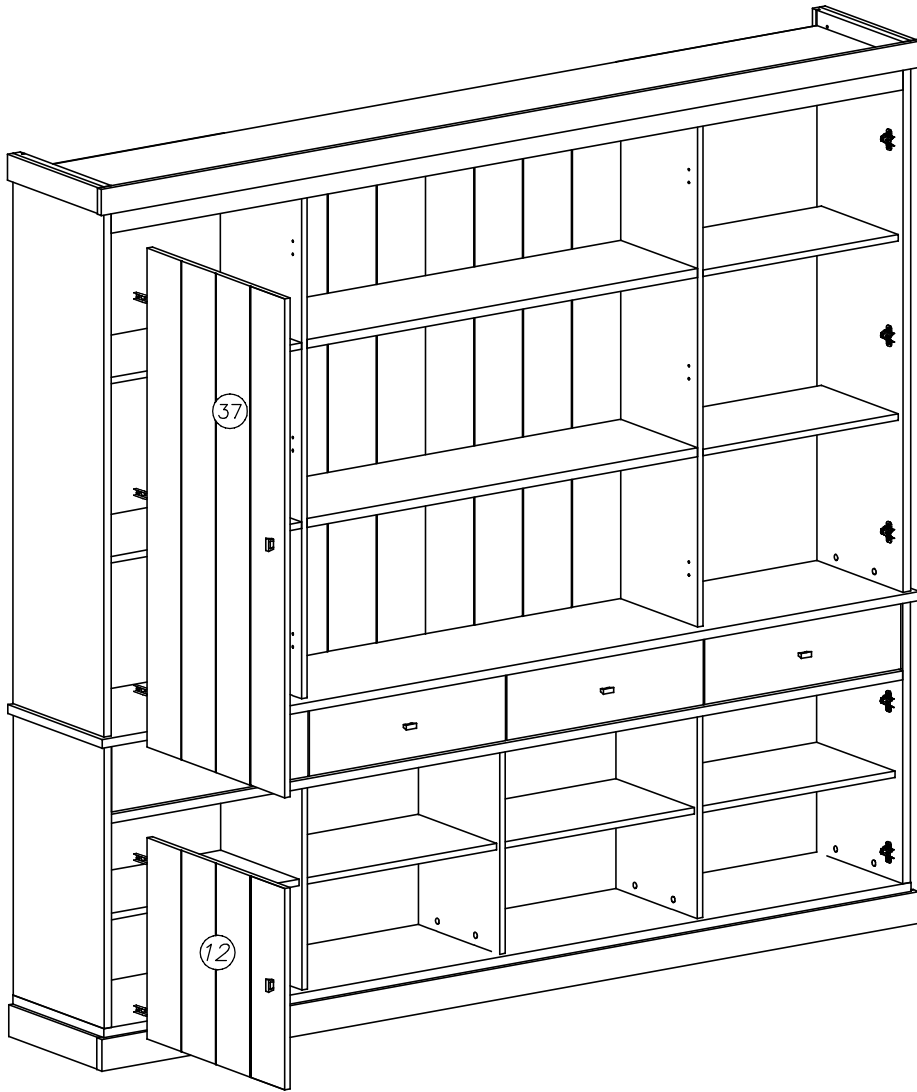



XXXII

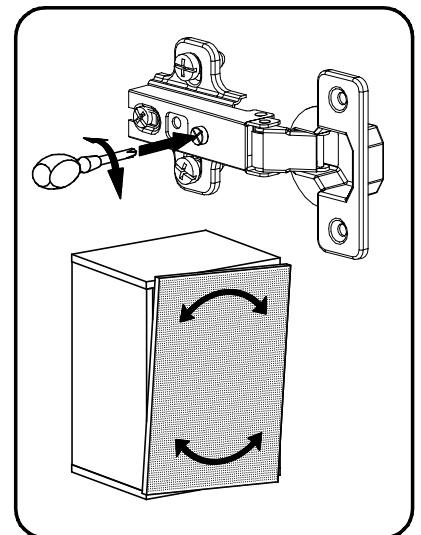
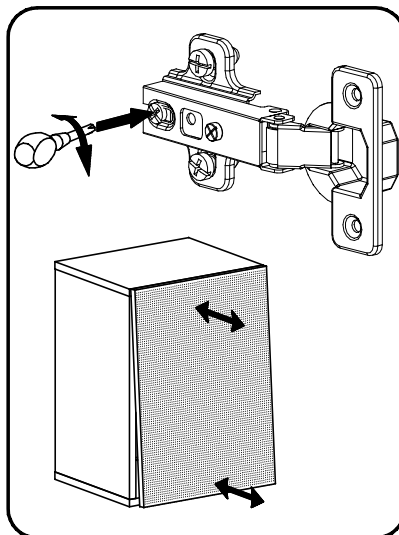
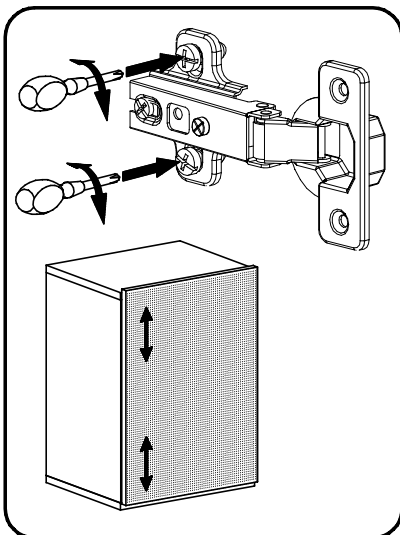
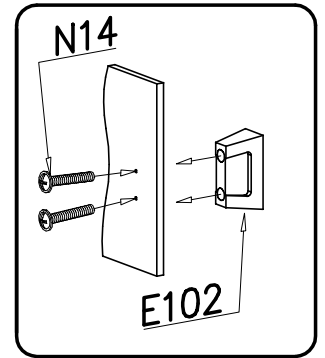
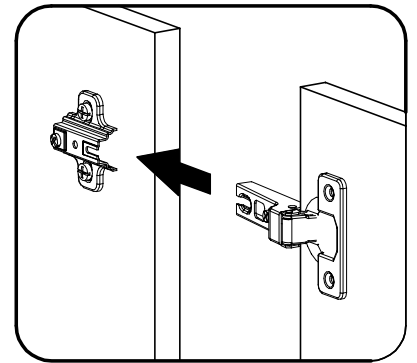
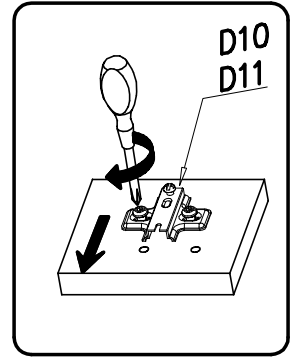
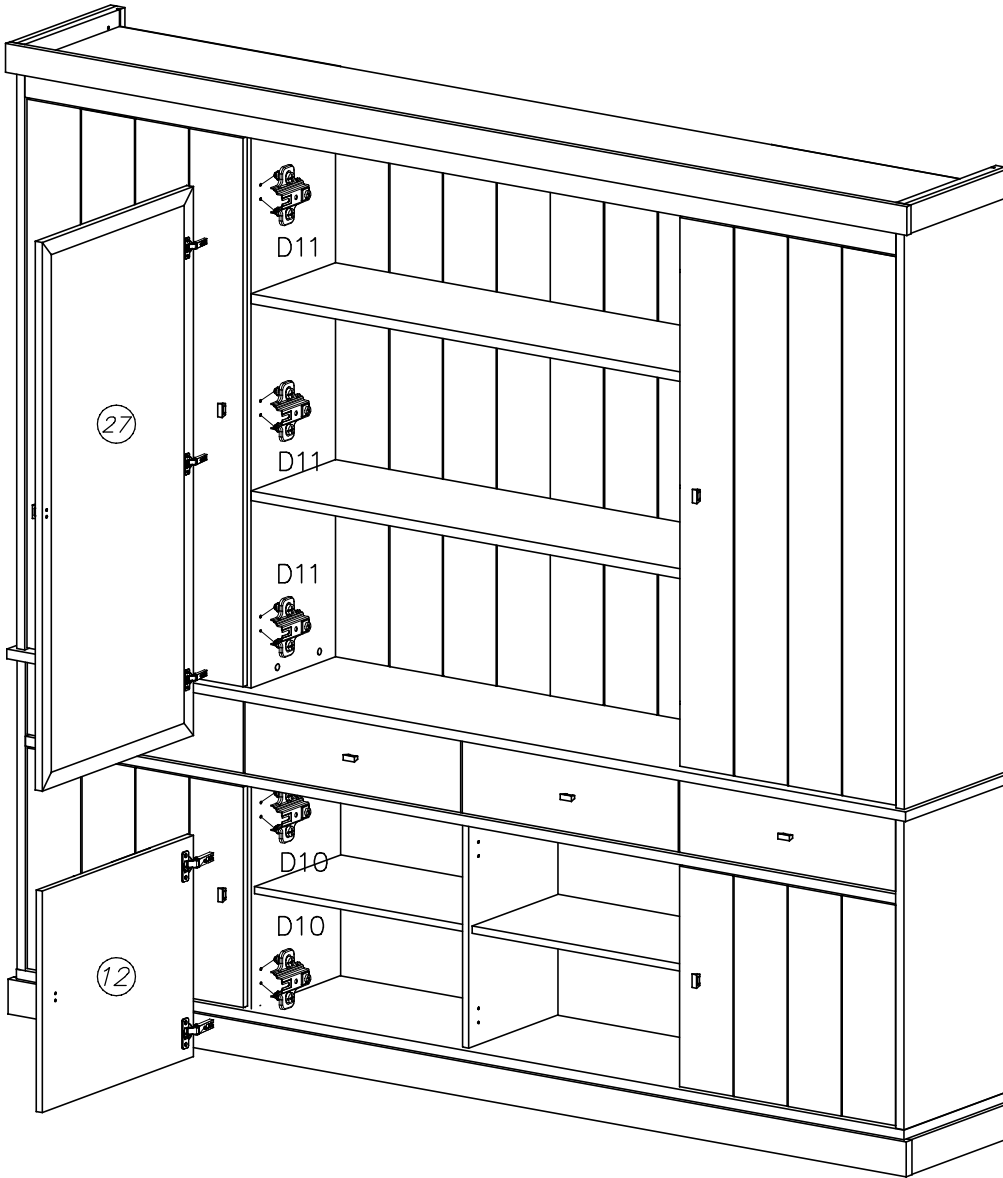



XXXIII

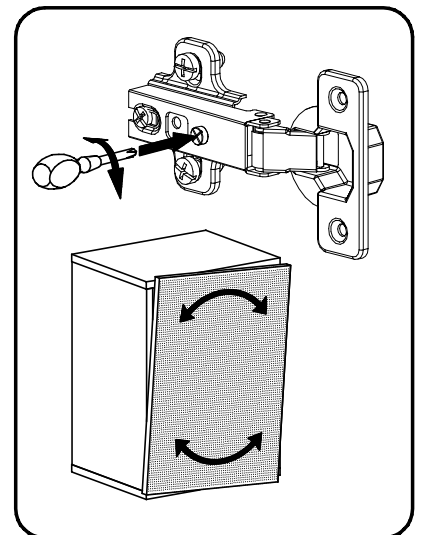
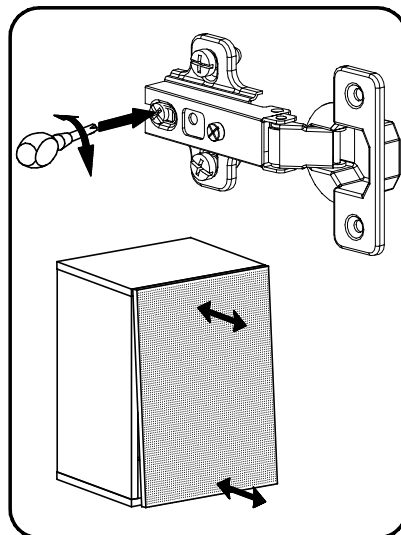
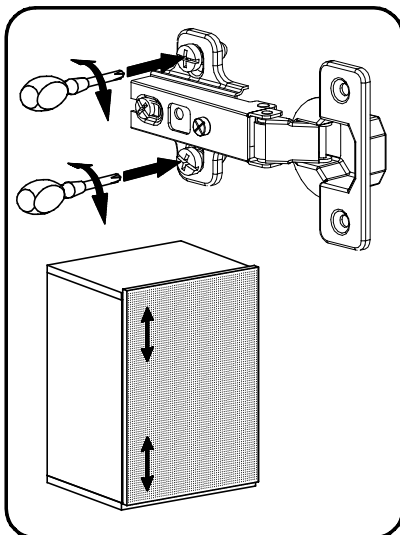
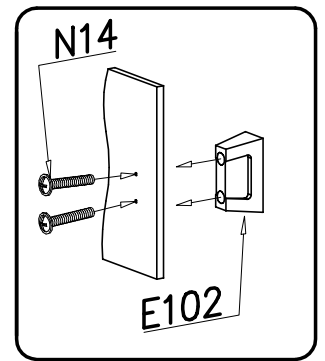
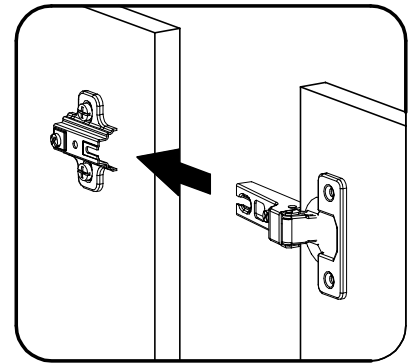
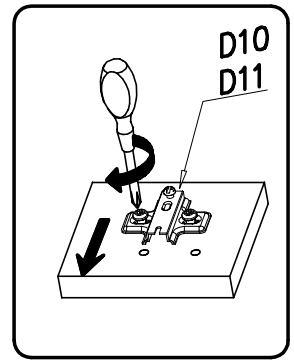
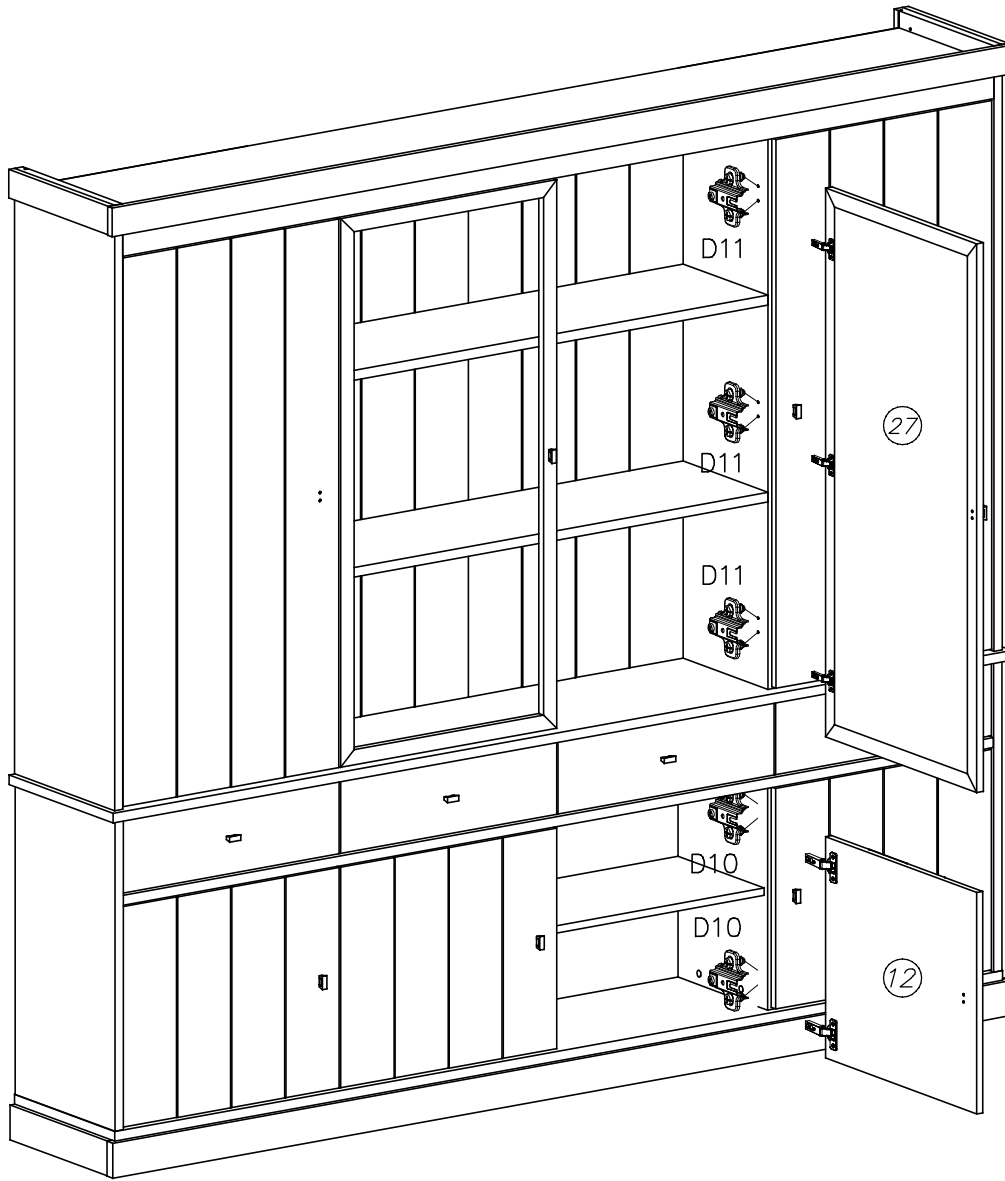



 Achtung • Opgelet • Uwaga • Dikkat • Вниманіе •
 Attention • Upozorneni • Figyelem • Allenzione • Atentie
 

D	Überschreiten Sie die angegebenen Maximalbelastungen nicht. Andernfalls kann das Möbelstück beschädigt oder zerstört werden.
GB	Do not exceed the maximum loads specified. Otherwise, the furniture may sustain damage or be irreparably damaged.
NL	Overschrijd de aangegeven maximale belastingen niet. Anders kan het meubelstuk worden beschadigd of vernield.
PL	Nie wolno przekraczać podanych maksymalnych wartości obciążenia. W innym przypadku można mebel uszkodzić lub zniszczyć.
TR	Belirtilen azami yuk degerini asmayiniz, aksi taktirde mobilya parcasi zarar gorebilir veya kullanilamazehale gelebilir.
RU	Не допускается превышение указанных максимальных нагрузок. В противном случае возможно повреждение или разрушение мебели.
FR	Ne dépassez pas les charges maximum indiquées. Sinon, le meuble peut être endommagé ou détruit.
CZ	Nepřekračujte uvedená maximální zatížení. V opačném případě může dojít k poškození nebo zničení nábytku.
HU	Tartsa be az engedélyezett maximális terhelhetőséget/teljesítményt. Különben a bútor és annak alkatrészei megsérülhetnek, tönkre mehetnek.
IT	Non superare il carico massimo indicato. Altrimenti il mobile rischia di rovinarsi o frantumarsi.
RO	Nu depasiti sollicitarile maxime specificate. Altfel puteti sa deteriorati sau sa distrugeti piesa de mobilier.
SK	Neprekročte uvedené maximálne zatažena. V opačnom prípade sa môže nábytok poškodiť alebo zničiť.
D	Die Befestigung des Möbelstückes an der Wand muss von einer fachkundigen Person vorgenommen werden, da für die Montage an die Wand angepasste Dübel erforderlich sind.
GB	A qualified professional is required when mounting furniture to the wall since dowels corresponding to the wall are required for this.
NL	Een vakkundige persoon dient het meubelstuk aan de muur te bevestigen; voor de montage aan de muur zijn immers aangepaste pluggen vereist.
PL	Mocowanie mebla do ściany mogą przeprowadzić wyłącznie wykwalifikowane osoby, z uwagi na zastosowanie odpowiednio dopasowanych kołków do rodzaju ściany.
TR	Mobilya parçasının duvara sabitlenmesi, duvar montajı için özel uyarlanmış dübeller gerektirdiğinden bu iş sadece bu konuda uzman bir kişi tarafından gerçekleştirilmelidir.
RU	Поскольку для монтажа на стене необходимо использовать специальные дюбели, мебель должна быть закреплена на стене квалифицированным персоналом.
FR	La fixation du meuble contre le mur doit être effectuée par une personne compétente car, pour le montage mural, il faut utiliser des chevilles adaptées.
CZ	Montáž nábytku na stěnu musí provést odborník, protože k montáži na stěnu jsou zapotřebí upravené hmoždinky.
HU	A bútorelemek falra rögzítését szakembernek kell végeznie, mert a rögzítéshez megfelelő tiplit kell használni.
IT	Il fissaggio del mobile alla parete deve essere eseguito esperte, dato che occorrono tasselli adeguati.
RO	Fixarea la perete a piesei de mobilier se realizeaza numai de catre personal competent, deoarece montajul de perete necesita dibluri adecvate.
SK	Upevnenie nábytku na stenu musí vykonať odborník, nakoľko sú pre montáž na stenu potrebné vhodné hmoždinky.

