











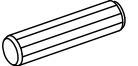













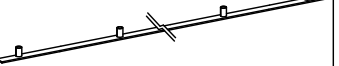

A  50x	B  50x	C  50x	D  77x	E  12x
F  3 set	G  5x	H  11x	I  10x	J  26x
K  32x	L  12x	M  6x	N  2x	O  2x
P  20x	Q  12x	R  1x	S  4x	T  4x
U  1x	V  4x	W  4x	X  20x	
Y  2x	Z  2x	AA  2x	AB  2x	AC  2x

1



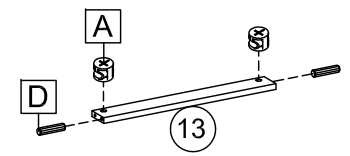
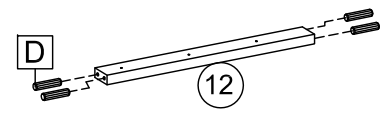
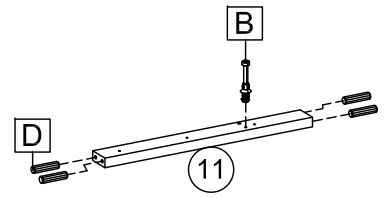
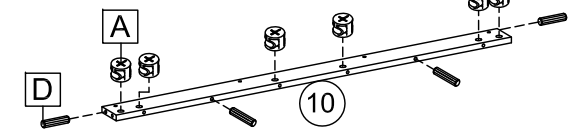
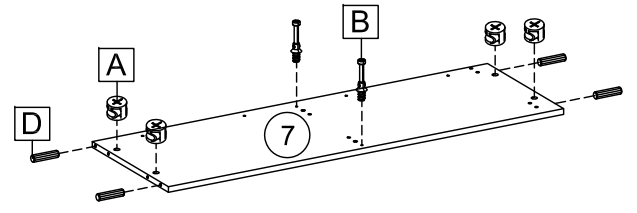
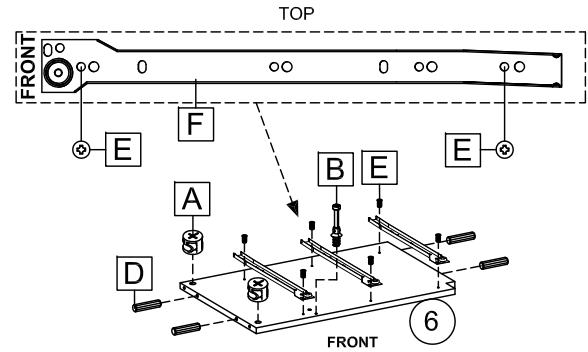
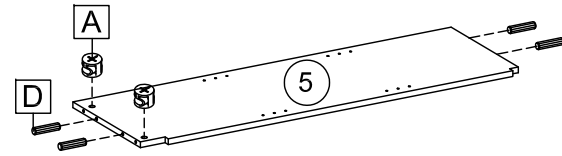
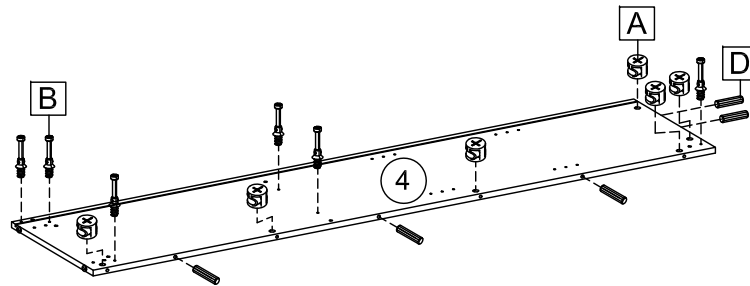
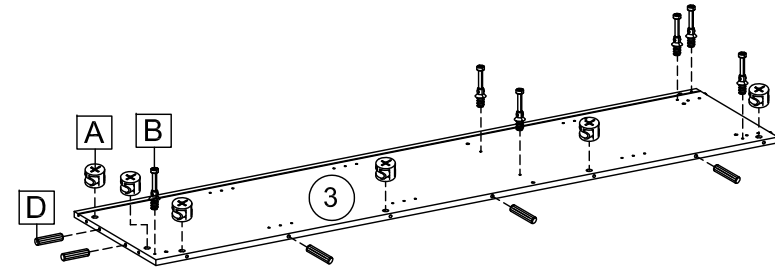
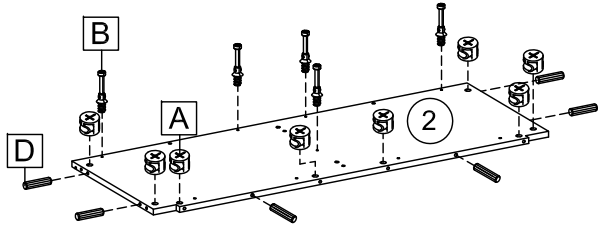
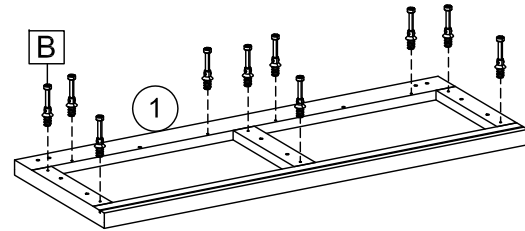
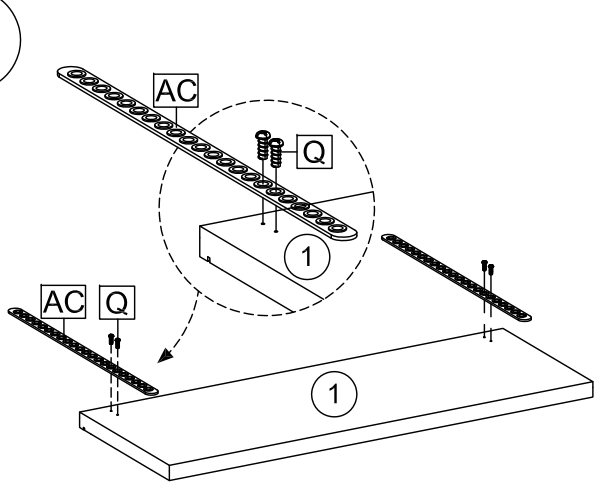
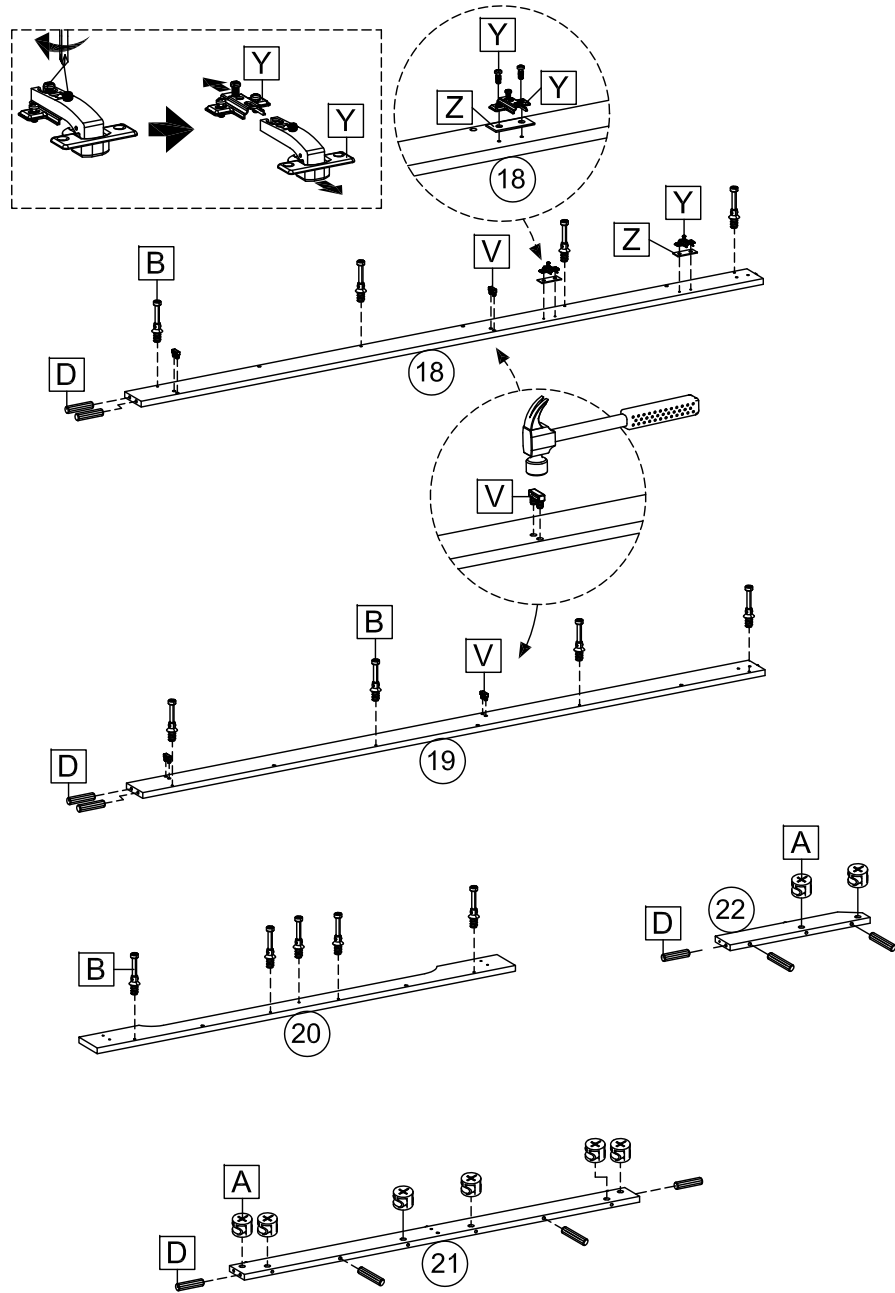

2

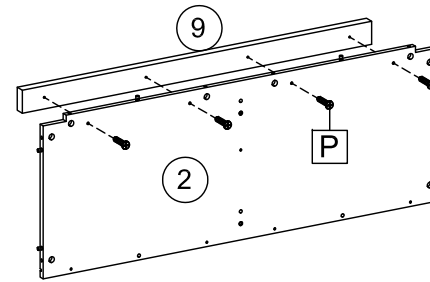

3

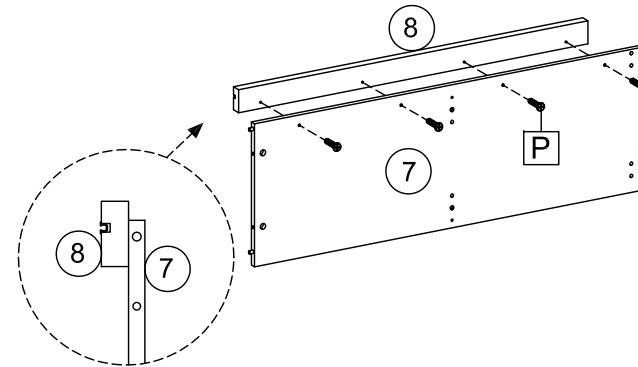

4

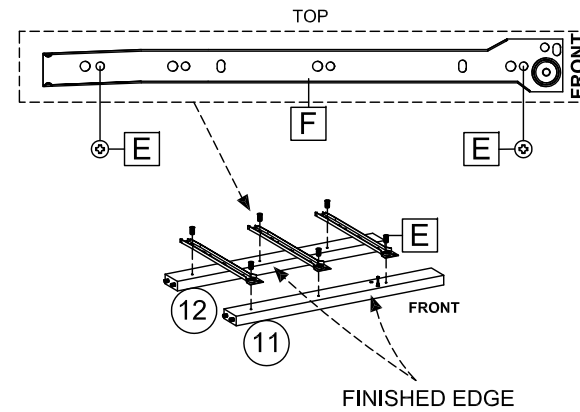

5

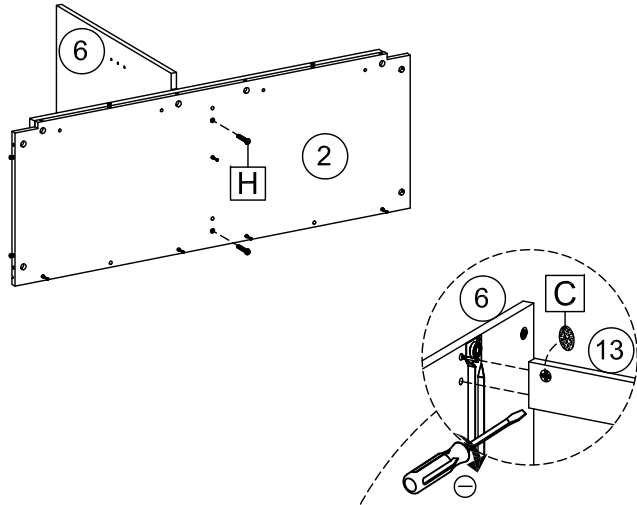

6

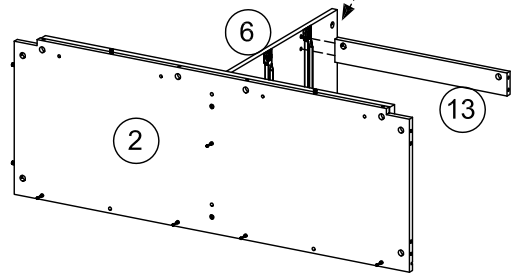

7

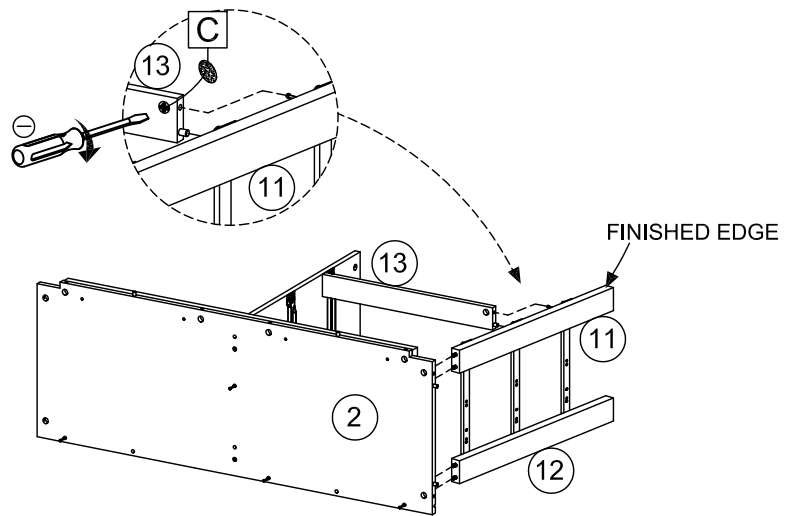

8

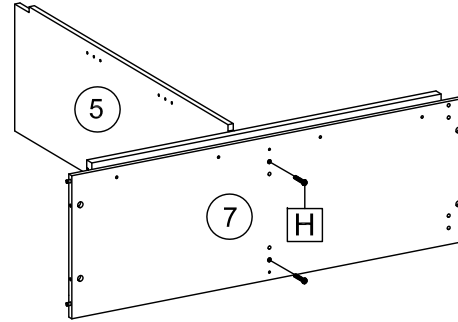

9

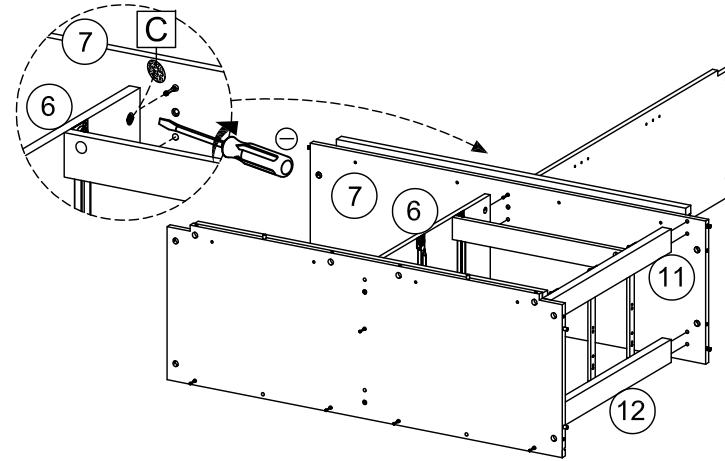

10

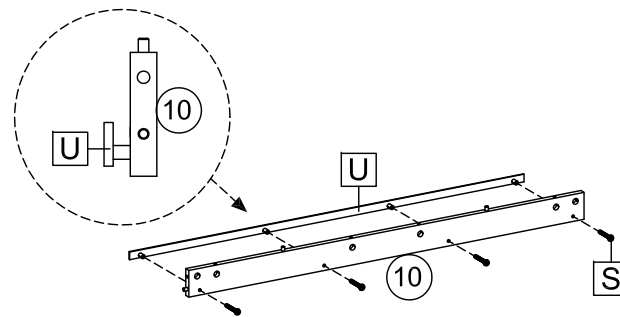

11

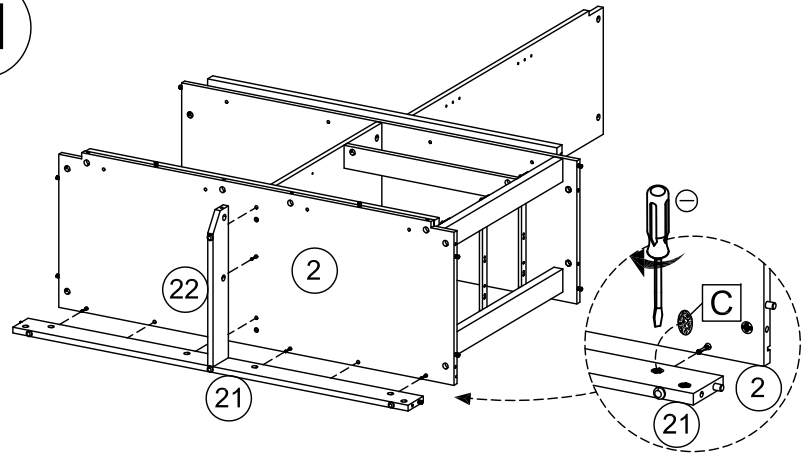

14

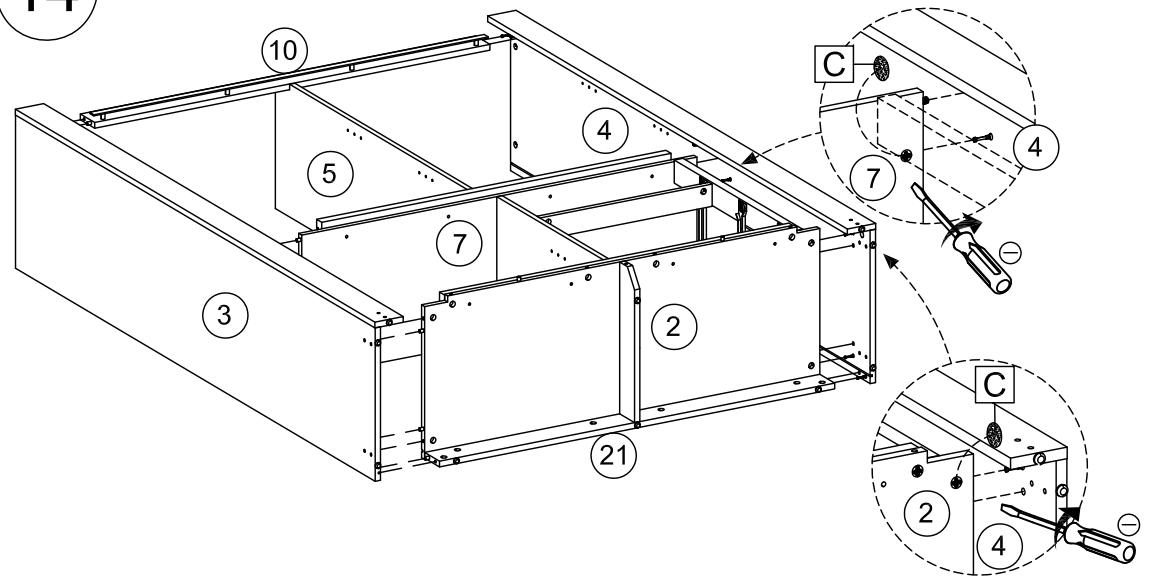

12

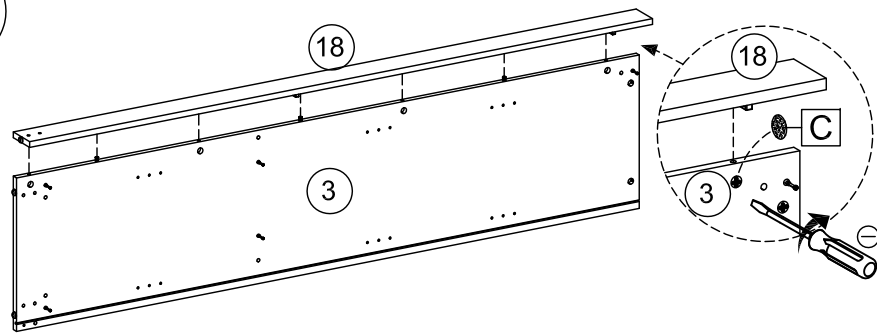

13

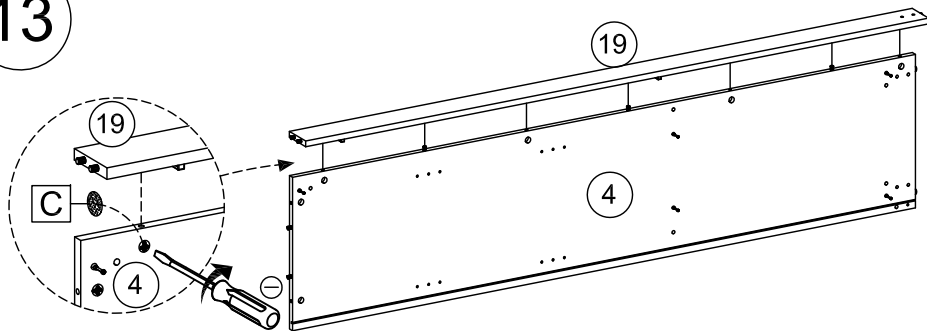

15

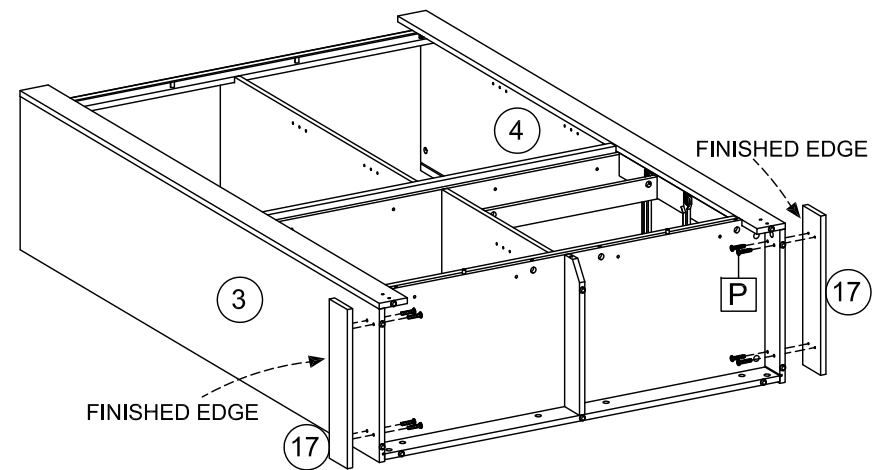

16

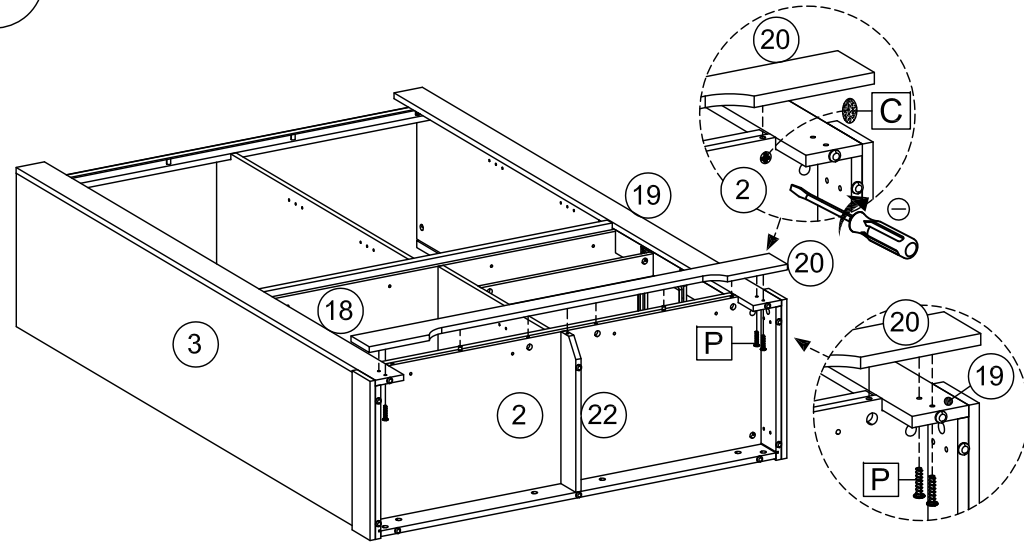

18

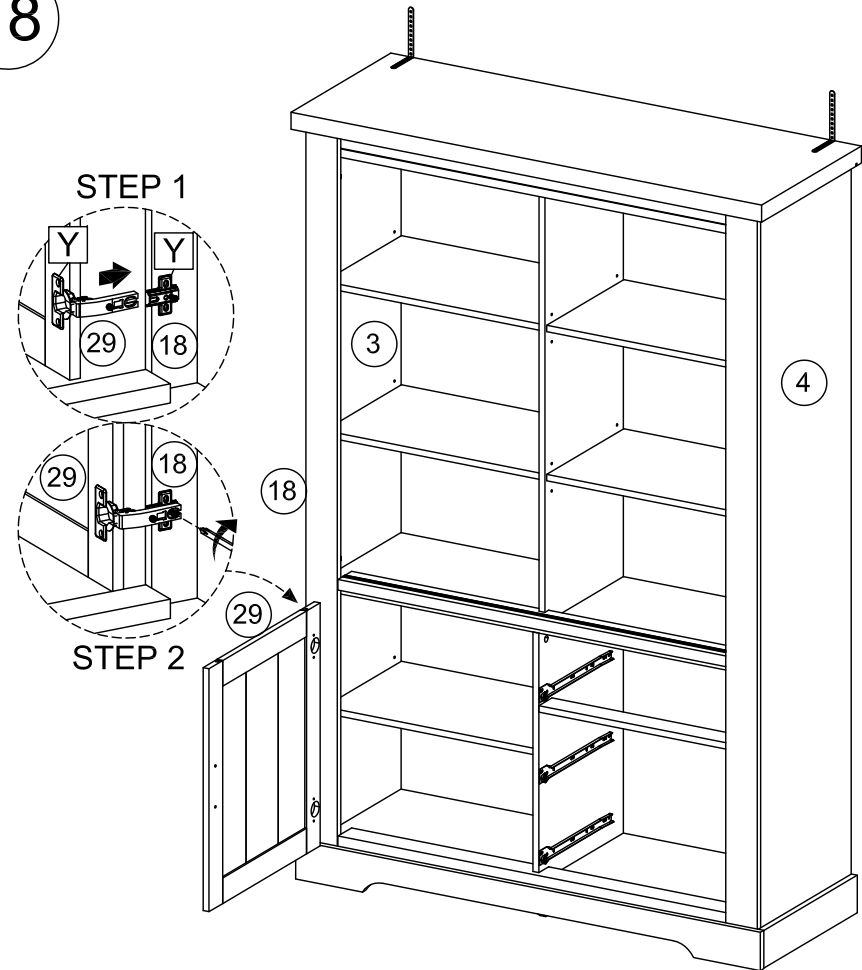

17

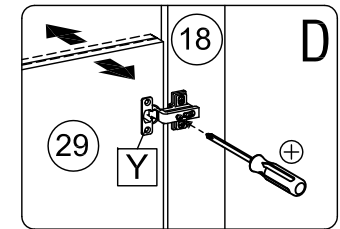
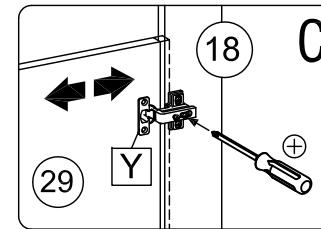
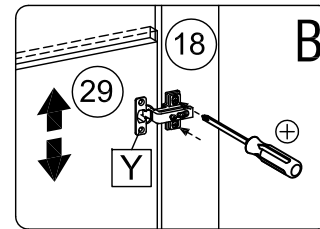
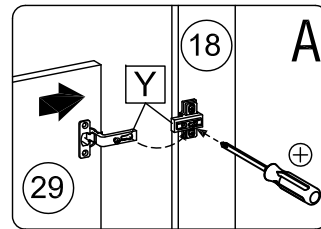
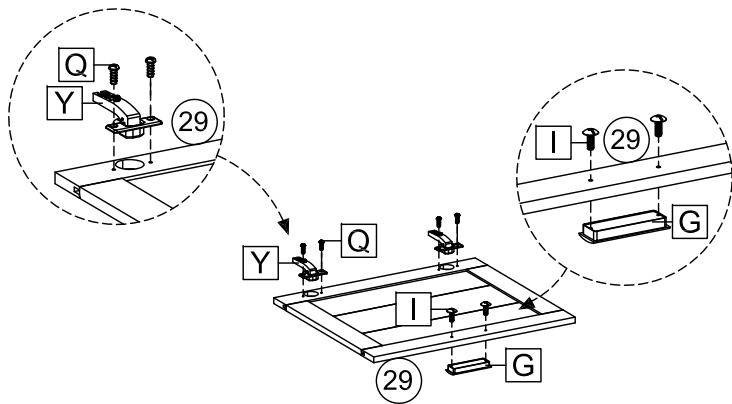

19

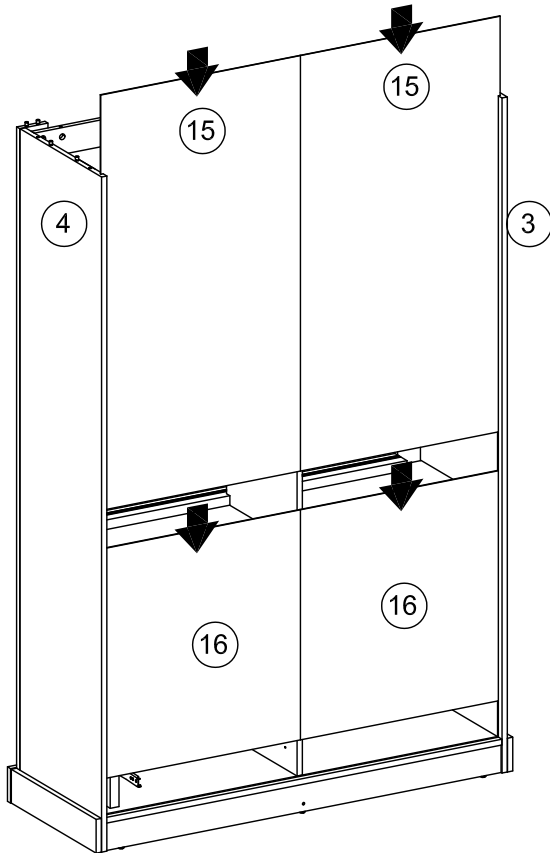

20

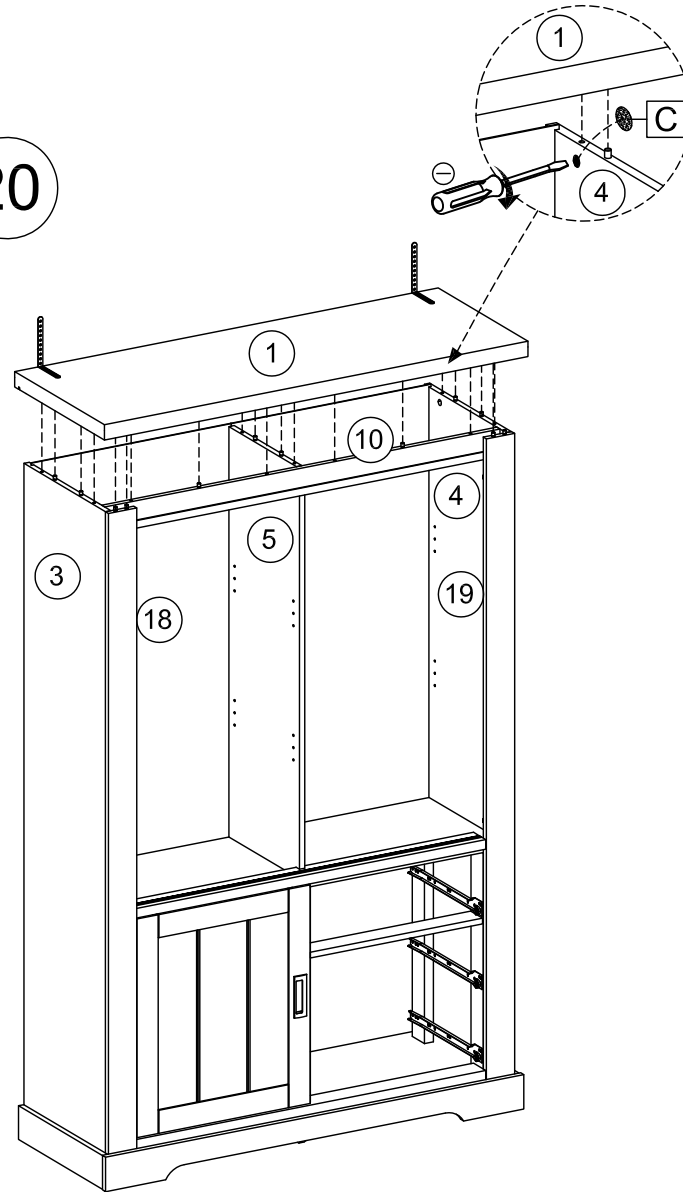

21

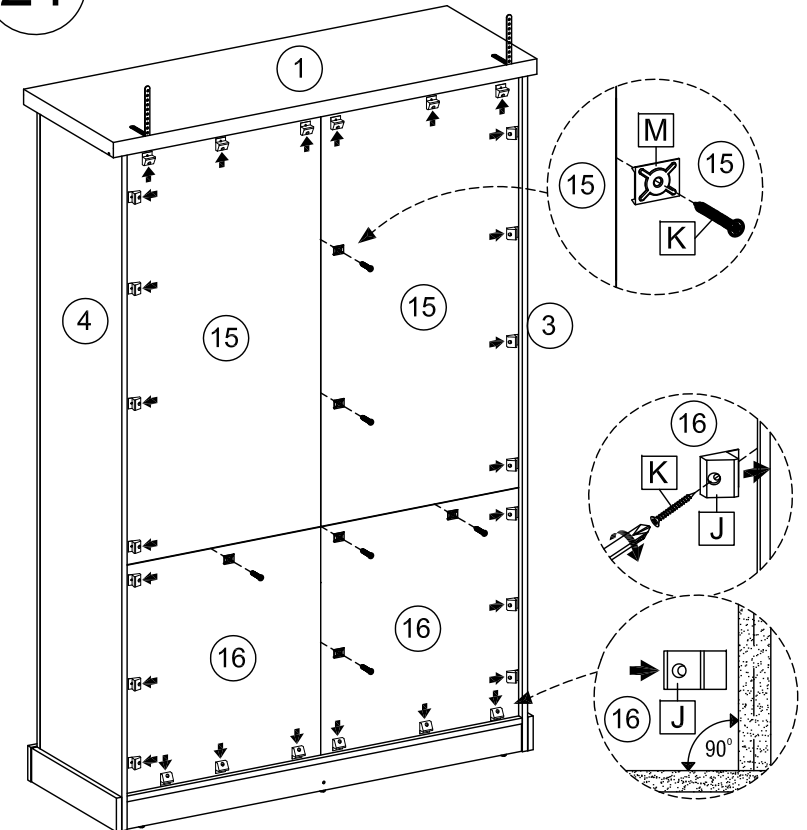

22

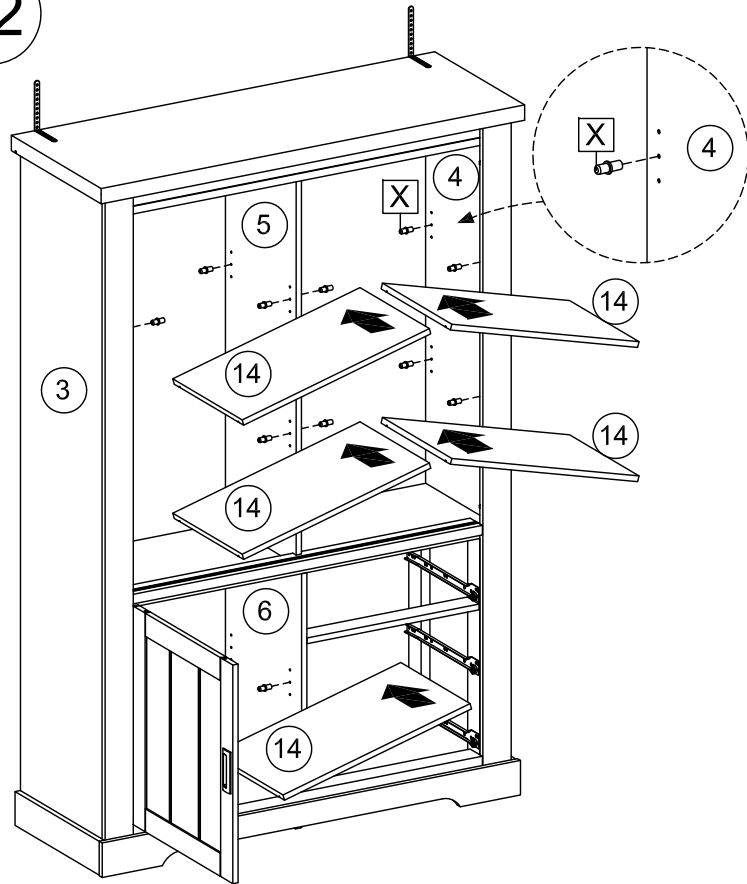

23

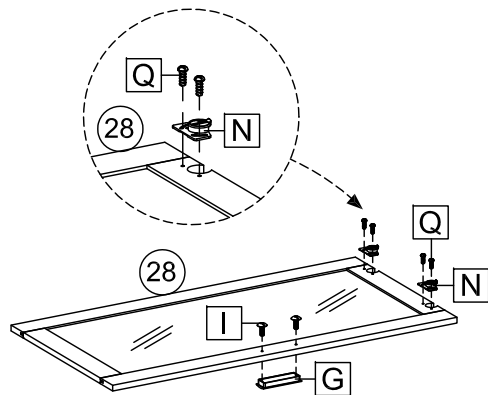

24

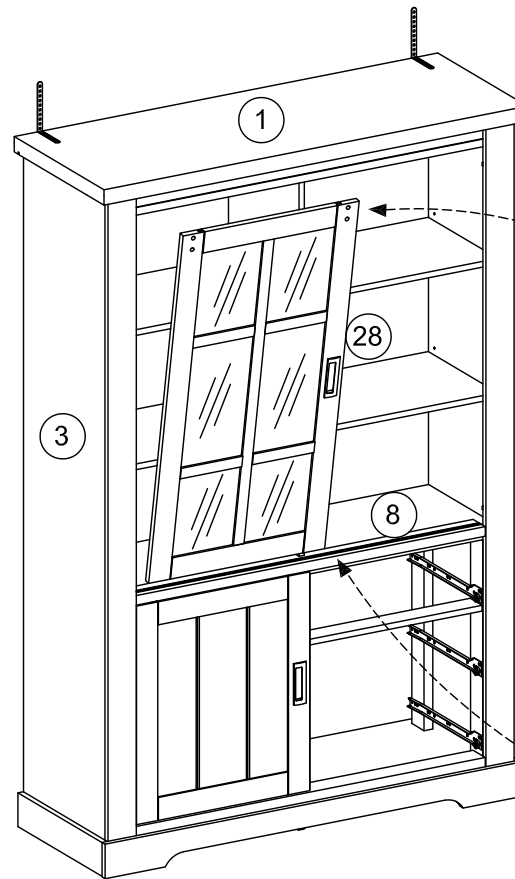

STEP 2

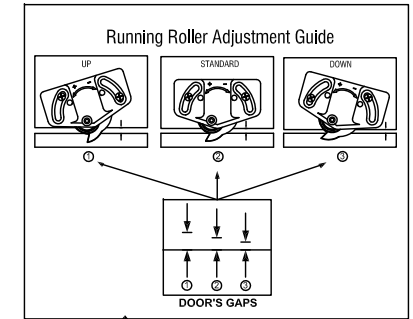
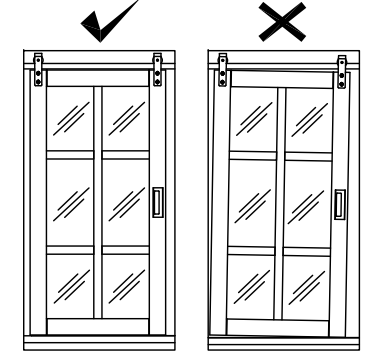
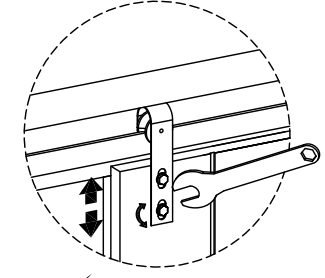
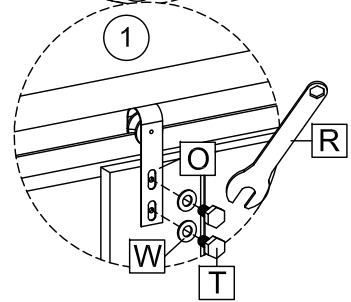
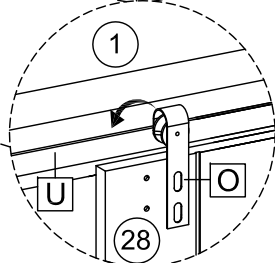
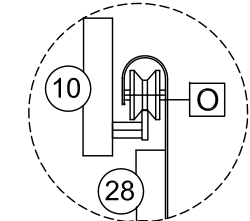

STEP 1

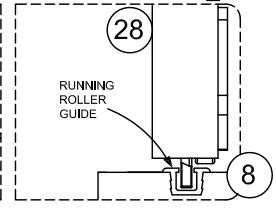
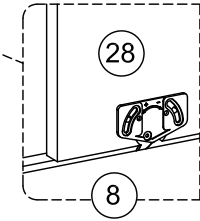

25

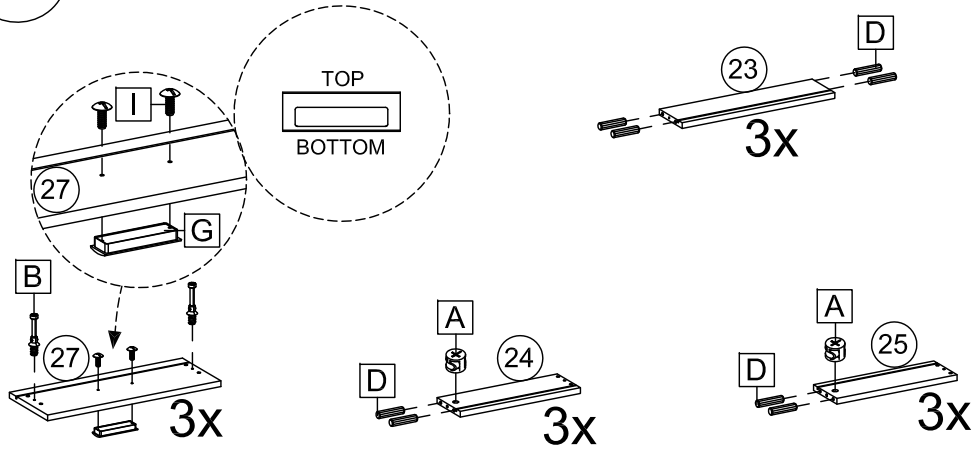

27

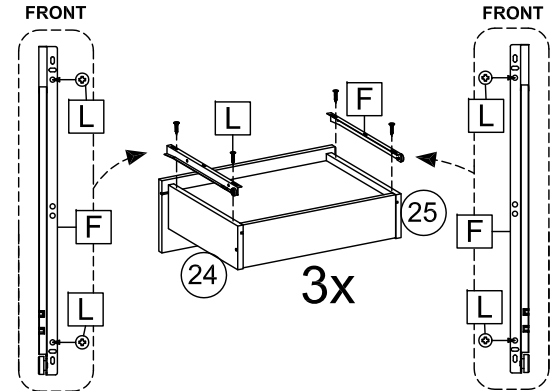

26

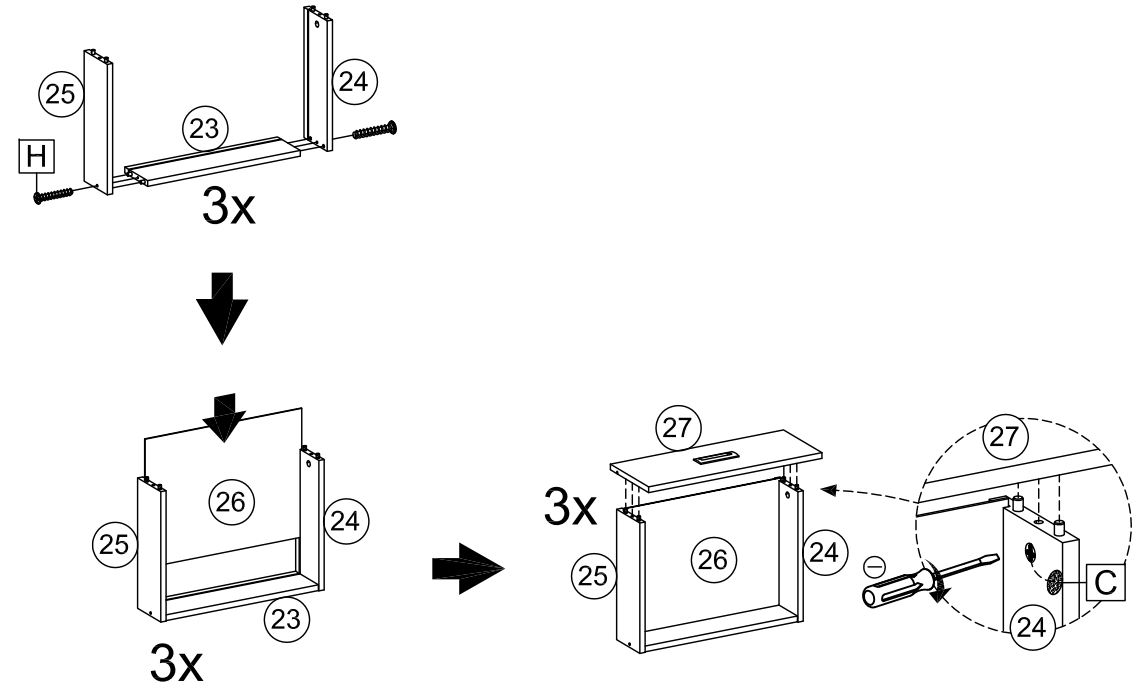

28

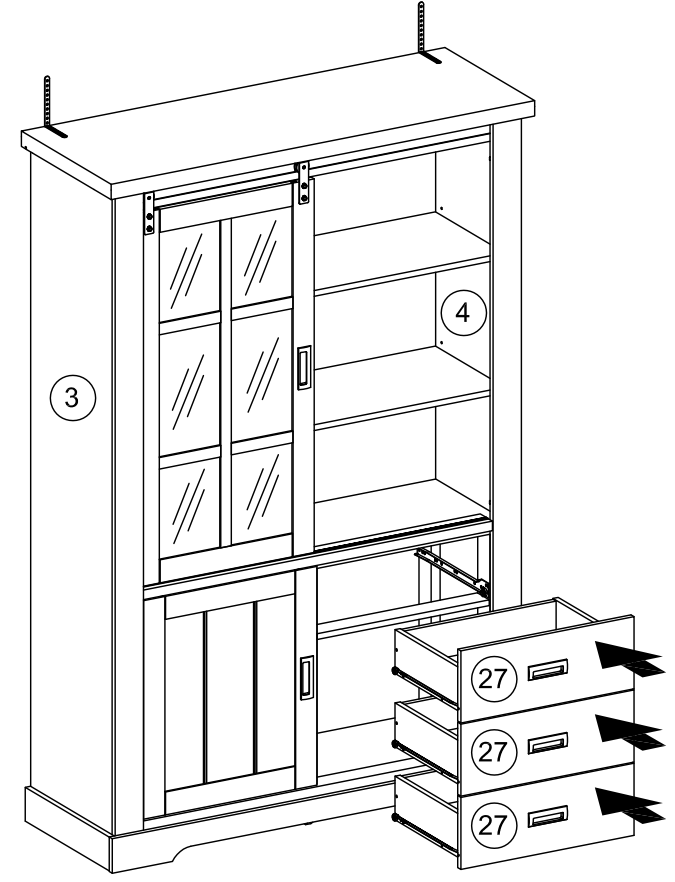

29

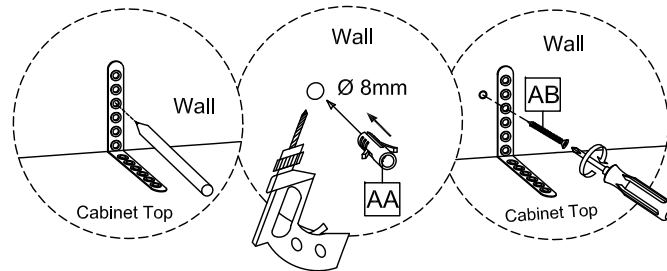
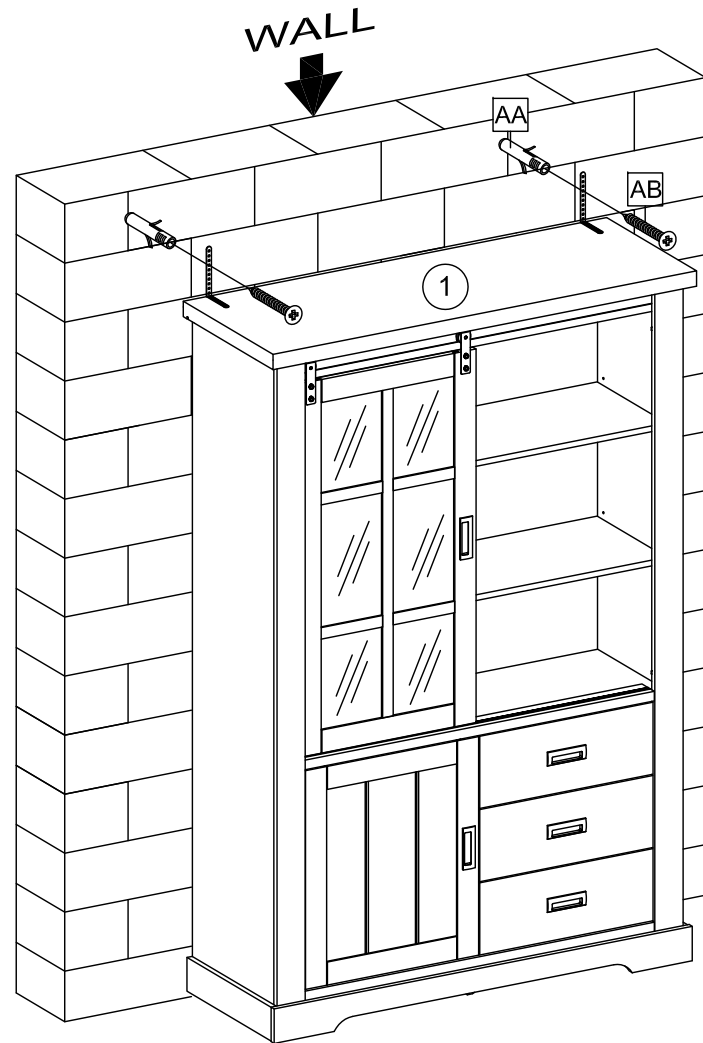

Onderhoud - Entretien - Maintenance



NL
 Oplosmiddel
 Reinigingsmiddel
 Verdunner
 Chemische producten
 Boenwas

FR
 Solvant
 Détergent
 Diluant
 Produits chimiques
 Cirage

GB
 Solvent
 Cleaner
 Thinner
 Chemical products
 Wax

NL

Algemene Informatie : Voor tafels geldt geen hete pannen, theeglazen en waxinelichtjes op de ondergrond plaatsen. Gebruik hiervoor altijd een onderzetter. Het meubel leegmaken en niet verslepen op de vloer bij eventuele verplaatsing.

Onderhoud: Met licht vochtige doek reinigen en hierna direct droog wrijven. Vocht op het bovenblad direct opnemen. De meubels zijn niet voor vochtige ruimten bestemd. Gebruik nooit een schuurspons, schuurmiddel, amoniak, oplosmiddel, reinigingsmiddel, verdunner, chemische producten, boenwas of producten zoals Pledge-was of dergelijke. Montage tekening opbergen.

Service na verkoop: Voor service na verkoop, ga naar uw leverancier met deze montage tekening.

Garantie: Het niet naleven van deze onderhoudsvorschriften doet de garantie met onmiddellijke ingang verloren gaan.

FR

L'information générale: Ne mettez jamais des casseroles chaudes, des verres à thé sur la surface des tables. Veuillez utiliser des sous verres. Videz le meuble avant tout déplacement. Portez le meuble et non pas le pousser sur le sol!

Entretien: Utilisez un chiffon légèrement humide et séchez aussitôt. Toute trace de liquide doit être enlevé immédiatement.

Les meubles ne sont pas adaptés aux pièces humides. N'utilisez jamais des éponges abrasives, amoniac, solvant, détergent, diluant, produits chimiques, cirage, des produits d'entretien comme Pledge etc... . Notice de montage à conserver.

Service après-vente : Pour tout service après-vente, rendez vous au magasin avec cette notice.

Garantie: Nous vous informons qu'en cas de non respect aux prescriptions sus - mentionnés que la garantie expire immédiatement.

GB

General information : Never put hot items on the table tops!

Empty furniture before moving it and do not drag the furniture over the floor.

Maintenance : Clean with slightly wet moistened cloth, wipe dry immediately. Wipe off wetness at once. Not suited for humid locations. Never use solvent, cleaner, thinner, chemical products or wax. Retain manual instruction.

For the after sales : For the after sales, go back to the shop with this assembly instruction.

Guarantee : Attention in case of non respect to the above prescriptions the warranty expires immediately.

Formulier DNV - Formulaire SAV - Form SAS

Terug te sturen naar uw winkel / A renvoyer à votre magasin

/ Send back to the shop

Datum / Date :

Uw gegevens / Vos donnees / Your data

Naam / Nom / Name :

Adres / Adresse / Address :

E-mail :

Tel. / GSM / Mobile :

Gegevens over het probleem / Donnees sur le problème / Information about the problem

Datum aankoop / Date d'achat / Date of purchase :

Naam model en meubelonderdeel :

Nom modèle et partie du meuble:

Name model and piece of furniture:

Onderdeelnr. of colli nr. (zie montageplan) :

N° de pièce ou coli (voir le plan de montage):

Number piece or coli number (view assemble plan):

Kleur of stof / Couleur ou tissu / Color or cloth:

Digitale foto's in bijlage / Photos digitales en annexe / Digital photos attached: **YES/ NO**

Gedetailleerde omschrijving van het probleem:

Description détaillée du problème:

Detailed description of the problem:

Dienst na verkoop

Beste klant,

Wij danken u voor de aankoop van dit meubel. Ondanks de zorg die wij besteden aan de productie en verpakking van onze meubelen, kan het voorkomen dat er iets ontbreekt of beschadigd is.

Is dit het geval vragen wij u om via bijgaand formulier uw DNV te melden aan de winkel waar u uw meubel heeft aangekocht.

Volg volgende onderstaande stappen in geval van schade:

1. Een foto van het complete meubel (onderdeel)
2. Een detailfoto van het probleem

Op die manier kunnen wij u zo vlug mogelijk helpen om uw probleem op te lossen.

Met vriendelijke groeten,

Service après vente

Cher client,

Nous vous remercions pour l'achat de ce meuble. Malgré tout les soins que nous consacrons à la production et le conditionnement de nos meubles, il est possible que quelque chose est manqué ou endommagé.

Si c'est le cas, nous vous demandons d'utiliser le formulaire ci-joint pour déclarer votre plainte au magasin où vous avez acheté vos meubles.

En cas de dommages, nous vous demandons également de prendre les photos suivants et de nous les envoyer:

1. Une photo du mobilier complet (partie)
2. Une photo de détail du problème

De cette façon, nous pouvons vous aider le plus vite possible afin de résoudre votre problème.

Sincèrement,

Service after sale

Dear customer,

Thank you for purchasing this piece of furniture. Despite the care we take in the production and packaging of our furniture, it is possible that something is missing or damaged.

If this is the case, we ask you to use the enclosed form to report your SAS to the store where you purchased your furniture.

Follow the steps below in case of damage:

1. A photo of the complete furniture (part)
2. A detailed photo of the problem

In this way we can help you solve your problem as quickly as possible.

With best regards,