

SHARON

GLASKAST
ARGENTIER
GLASS CABINET

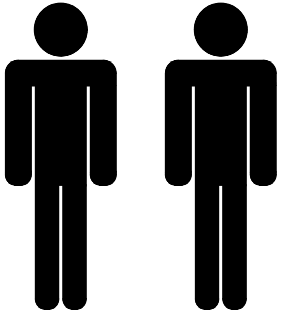

Montage par 2 Personnes
Assembling with 2 Persons
Opbouw met 2 Personen

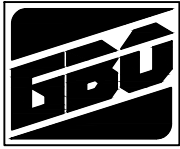
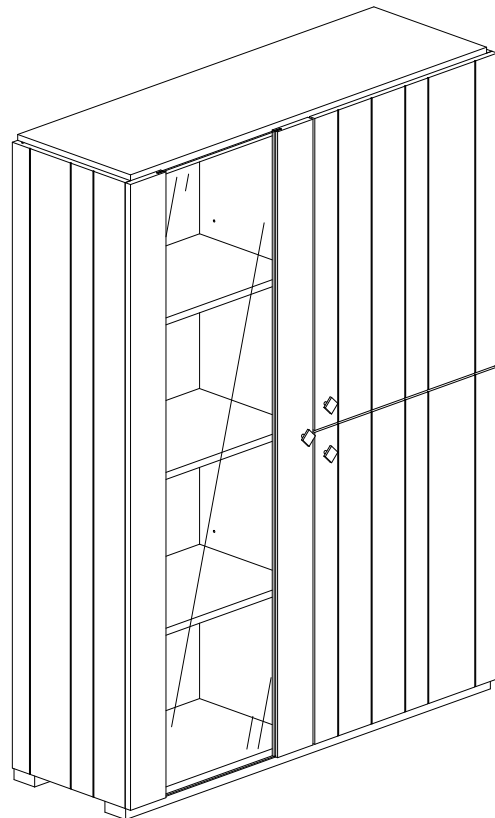
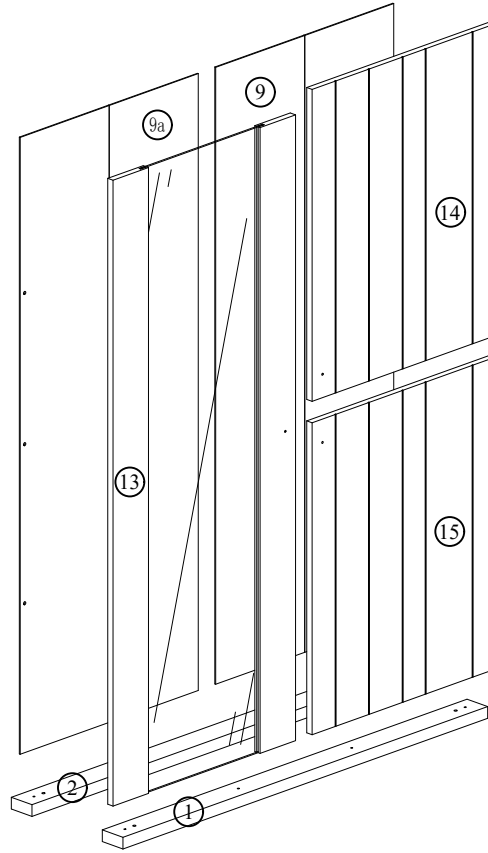
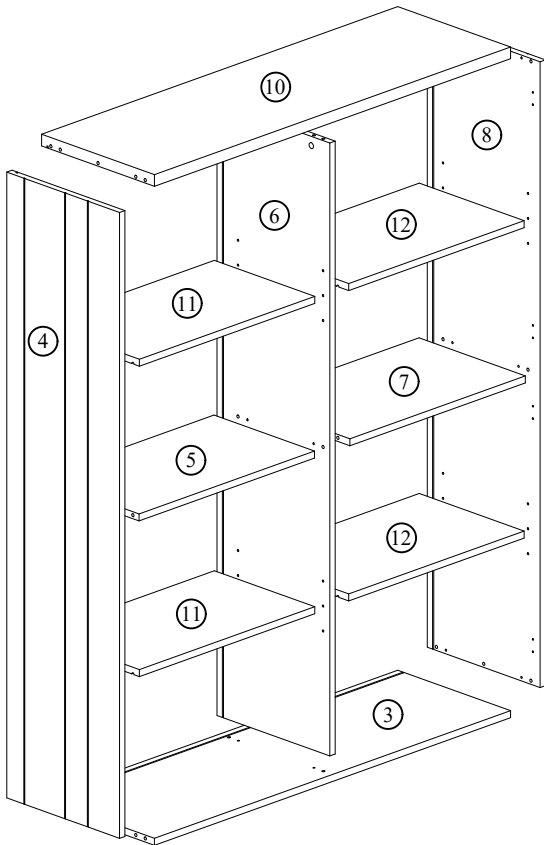

1650mm
1242mm
400mm

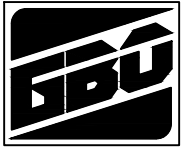

SHARON

GLASKAST
ARGENTIER
GLASS CABINET

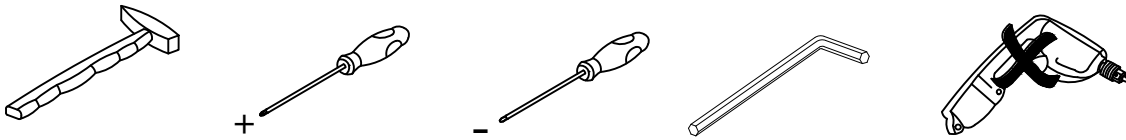
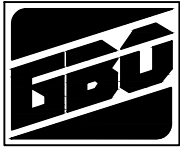





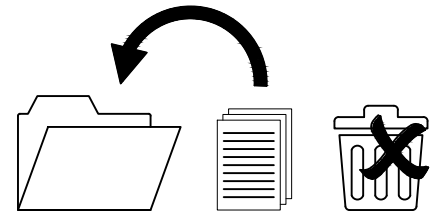
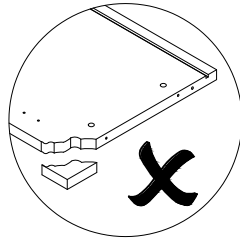
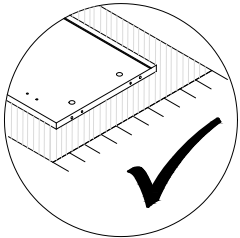

SOLVANT
DILUANT
OPLOSMIDDEL
OF THINNER

FR Entretien: utilisez un chiffon légèrement humide et séchez aussitôt. Toute trace de liquide doit être enlevé immédiatement. Meuble inadapté aux pièces humides. N' utilisez jamais du solvant, détergent, diluant, produits chimiques ou cirage. Notice du montage à conserver. Pour tous service l'après-vente, rendez-vous au magasin avec cette notice.

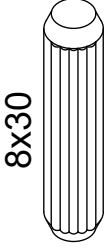
GB Maintenance: clean with slightly wet moistened cloth, wipe dry immediately. Wipe off wetness at once. Not suited for humid locations. Never use Solvent, cleaner, thinner, chemical products or wax. Retain manual instruction. For the after sales, go back to the shop with this assembly instruction.

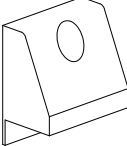
NL Onderhoud: met licht vochtige doek reinigen hierna direct droog wrijven. Vocht op het bovenblad direct opnemen. De meubels zijn niet voor vochtige ruimten bestemd. Gebruik nooit Oplosmiddel, reinigingsmiddel, verdunner, chemische producten of boenwas. Montage tekening opbergen. Voor Service na verkoop, ga naar uw leverancier met deze montage handleiding.

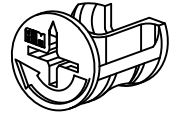
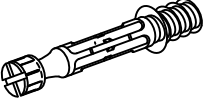
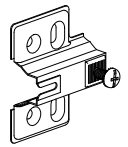
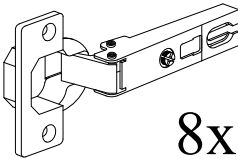

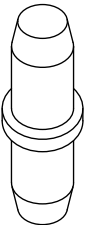
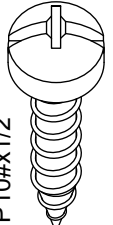
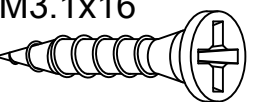
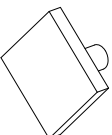
 A 8x30 28x	 B M3.5x14 32x	 BS 16x	 D M6x40 10x	 E 18x
 F 18x	 HG5a 8x	 HG5b 8x	 K 1x M4	 M M4x32 3x
 N 16x	 R TP10#x1/2" 16x	 SC 16x M3.1x16	 SHD33 3x	

1

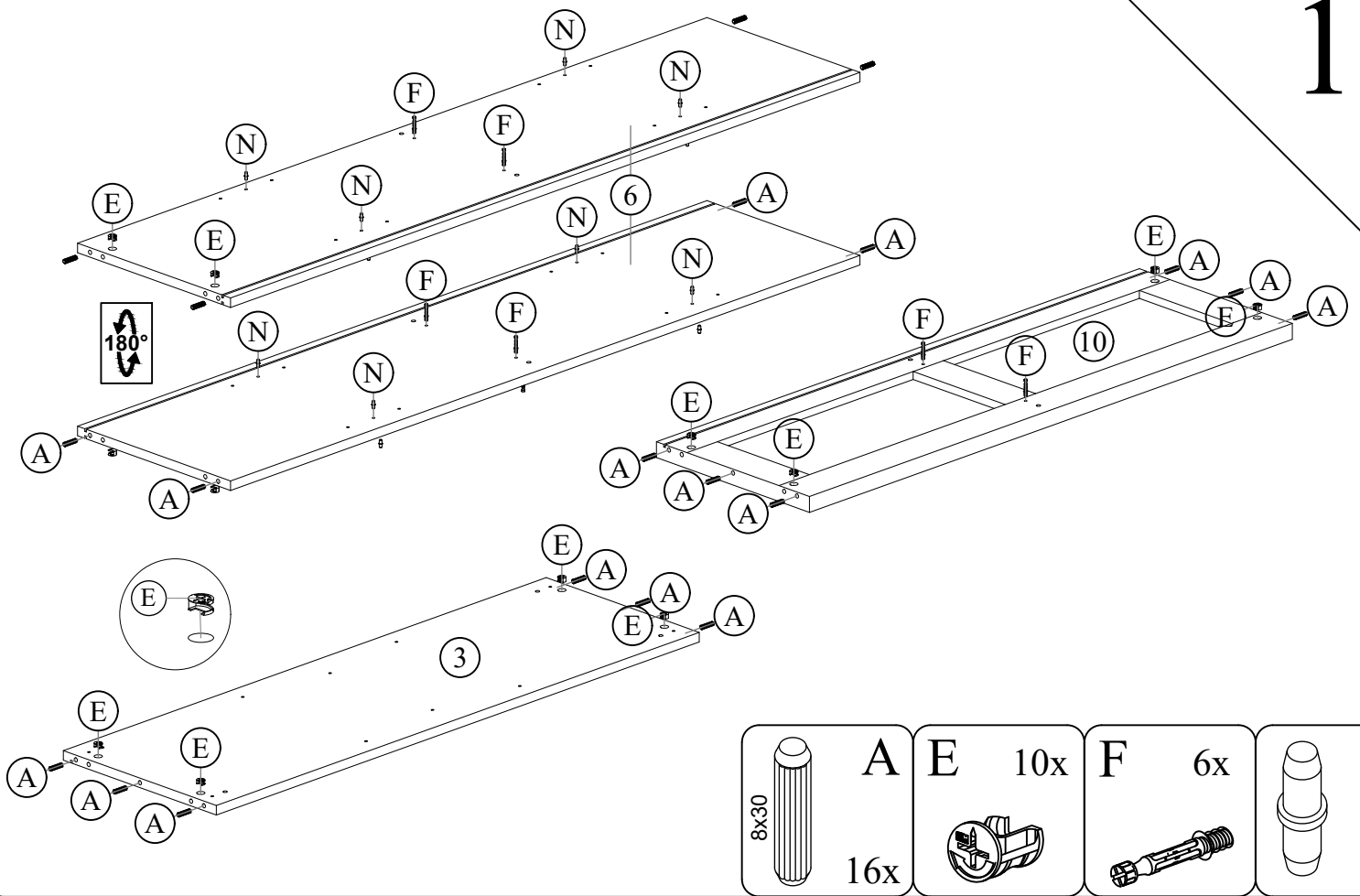

2

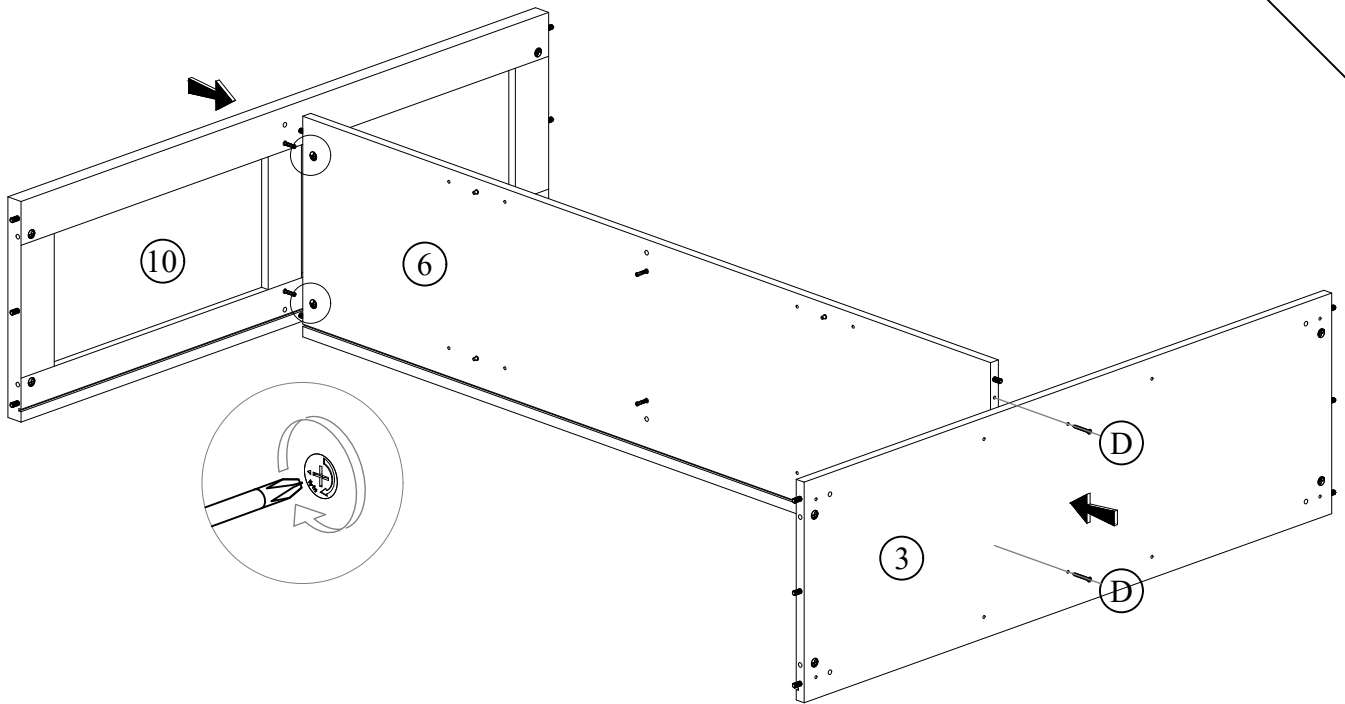



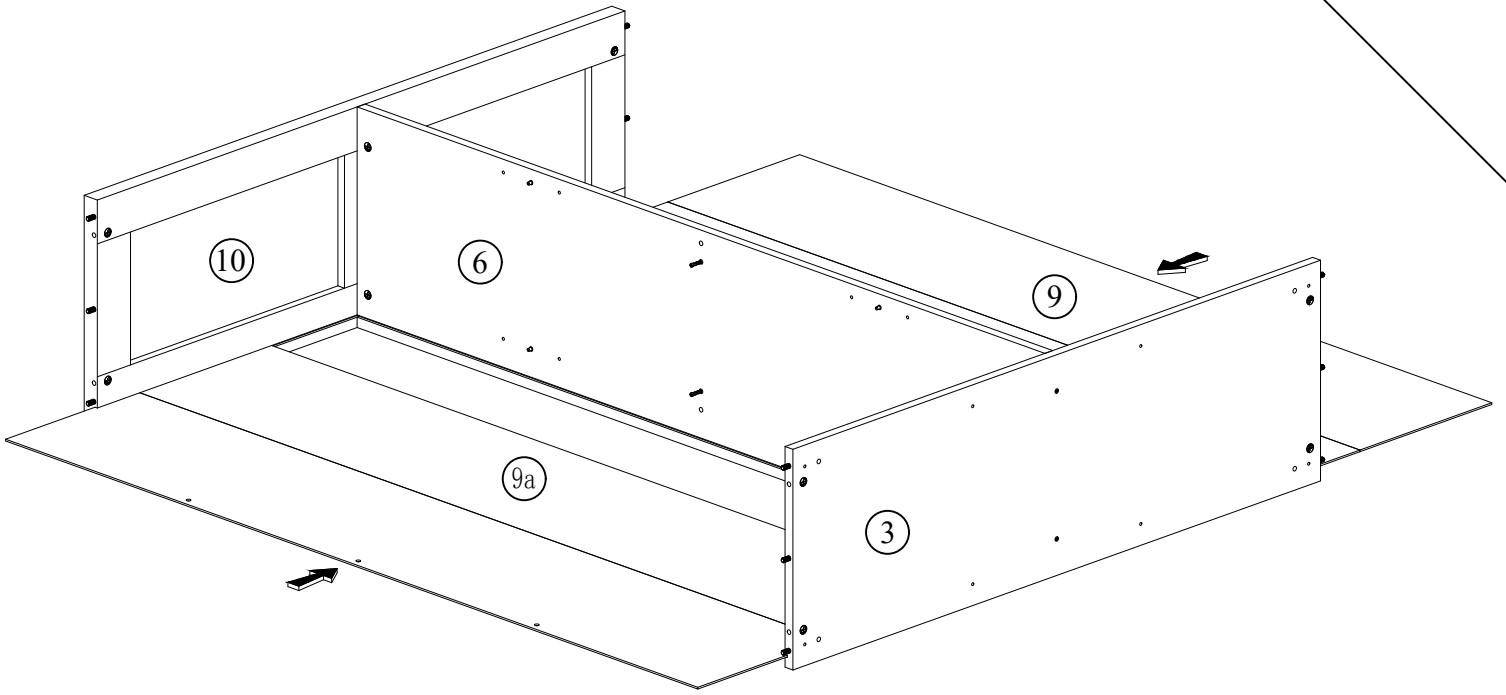

3

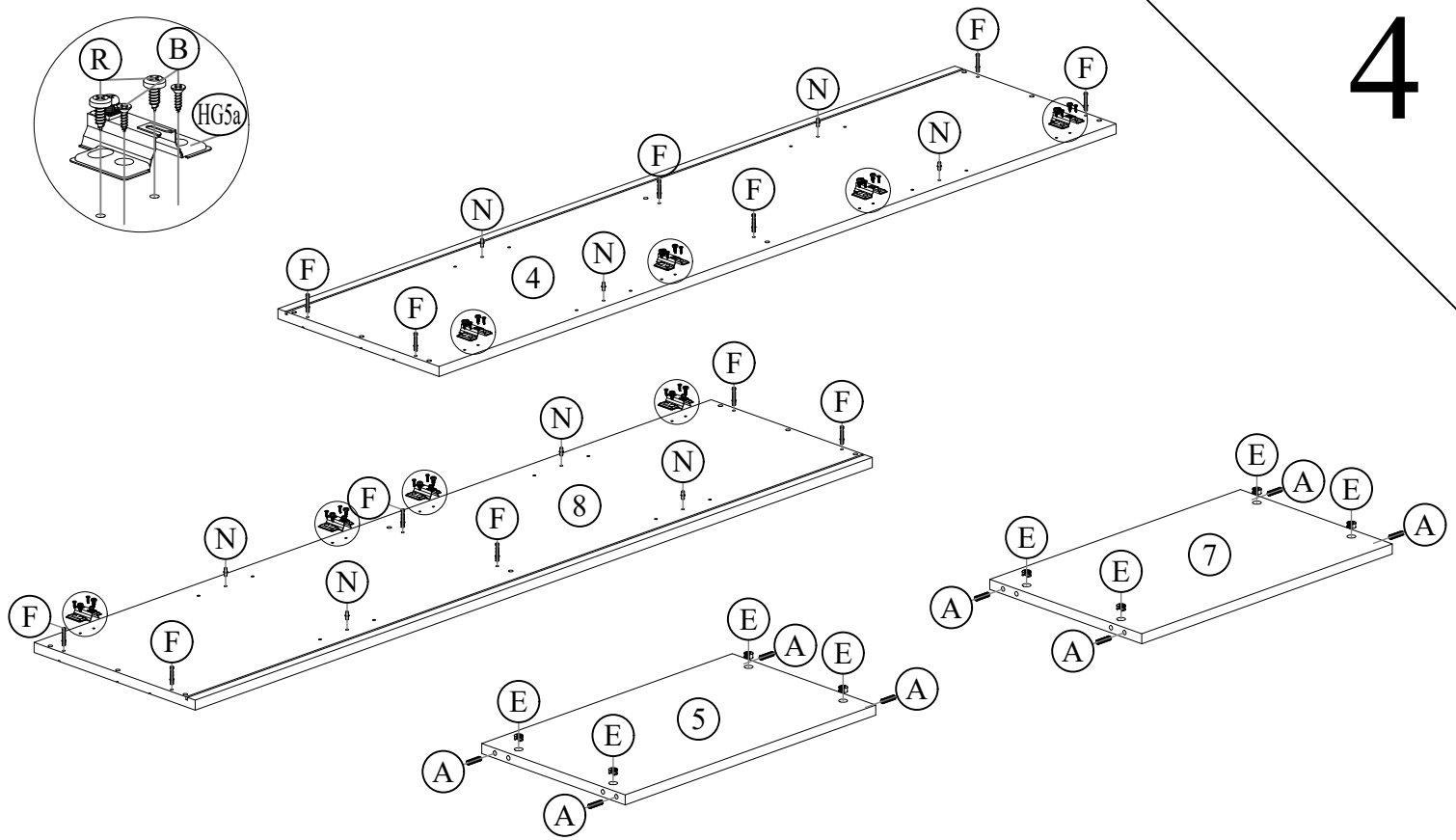

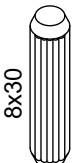
4

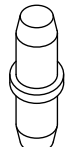
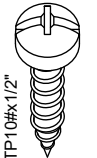

 8x30	A 8x	 M3.5x14	B 16x		E 8x		F 12x		HG5a 8x		N 8x		R TP1.0x1/2"	16x
---	----------------	--	-----------------	---	-------------	---	--------------	---	-------------------	---	----------------	---	------------------------	-----

5

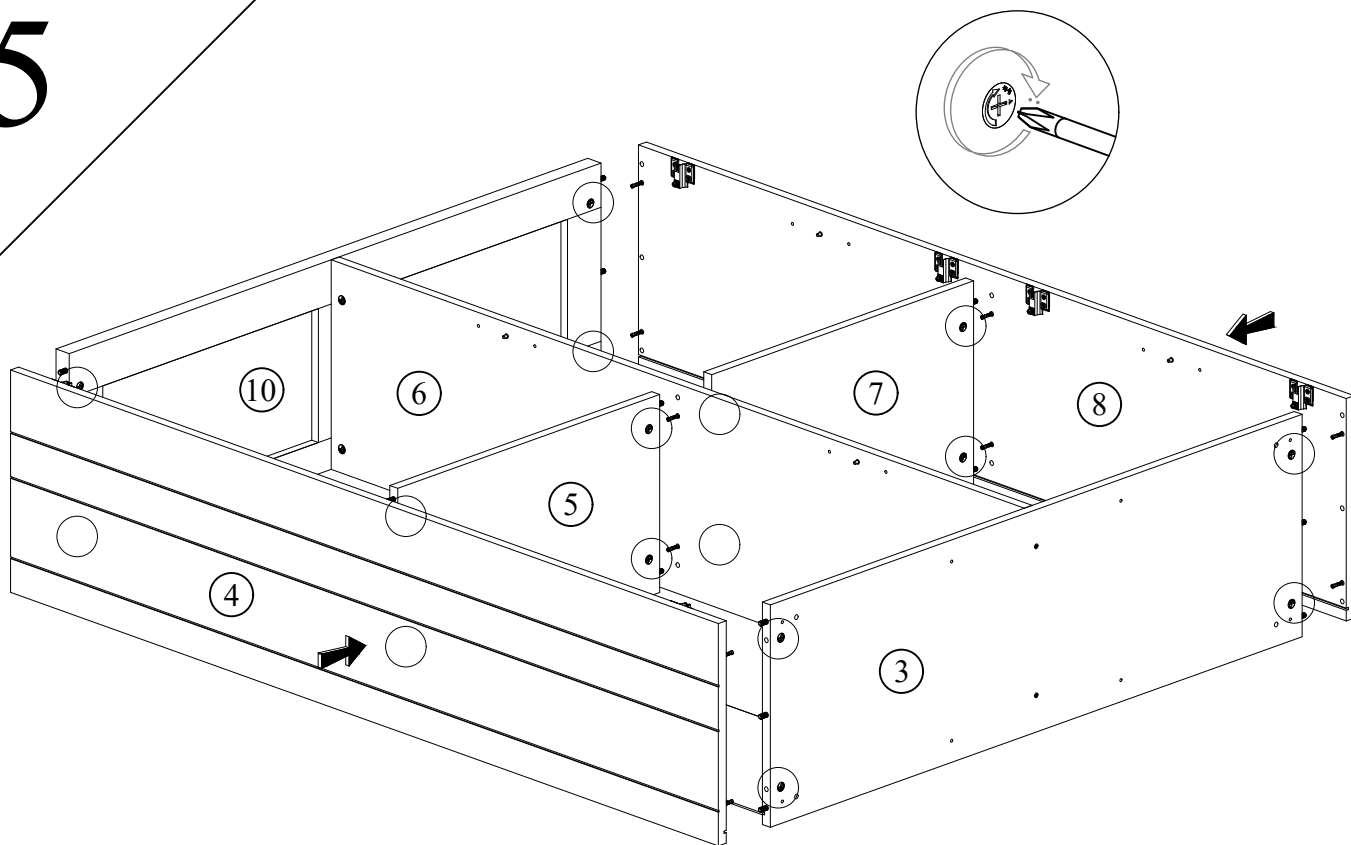

6

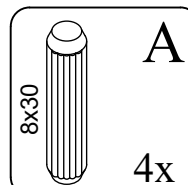
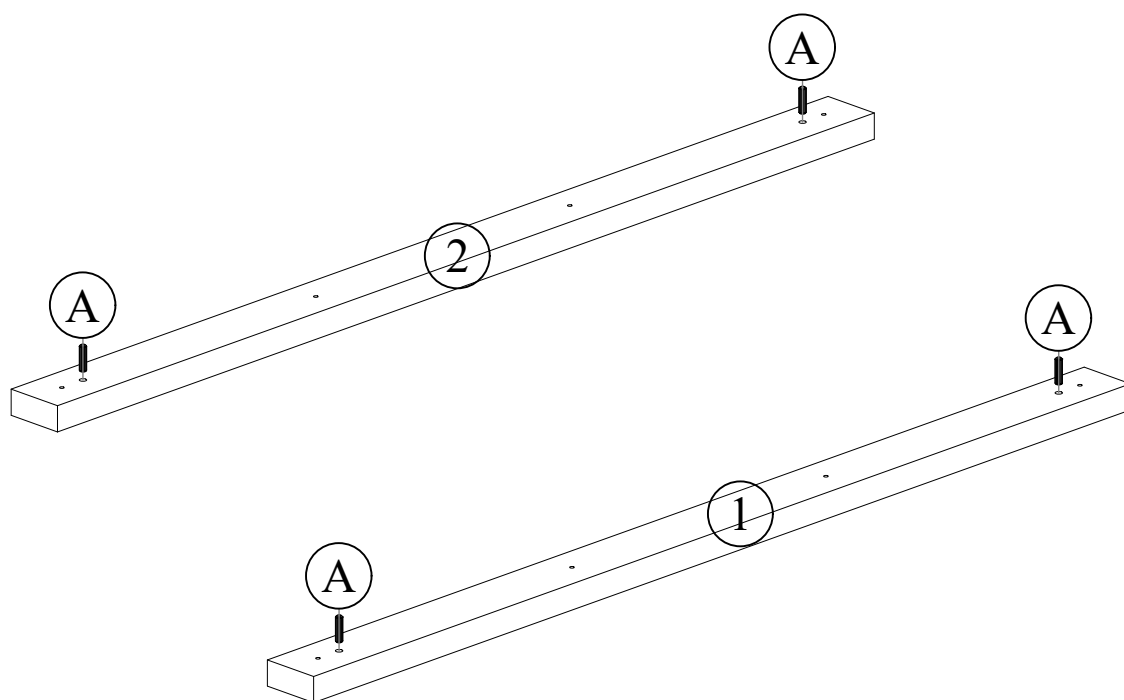

7

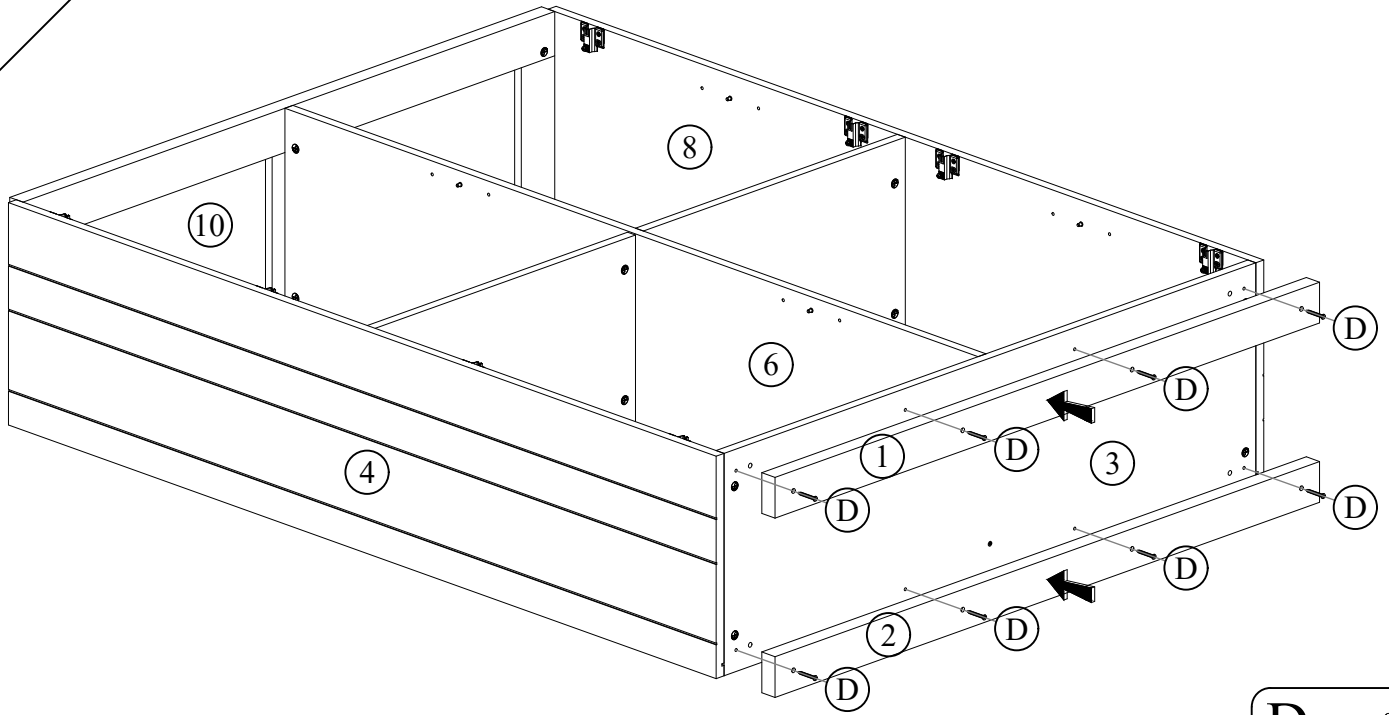

8

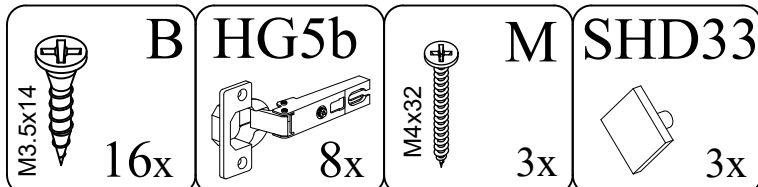
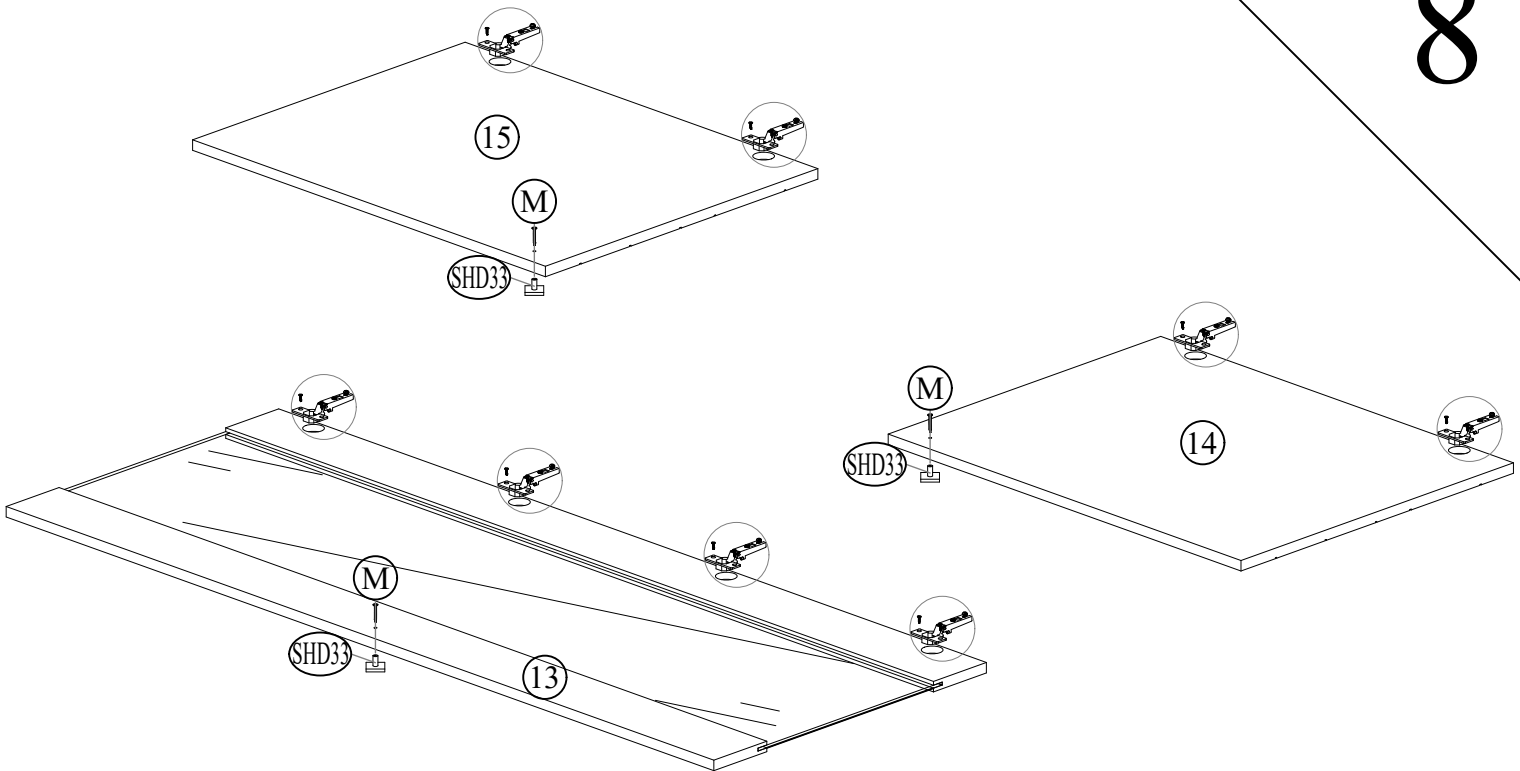

9

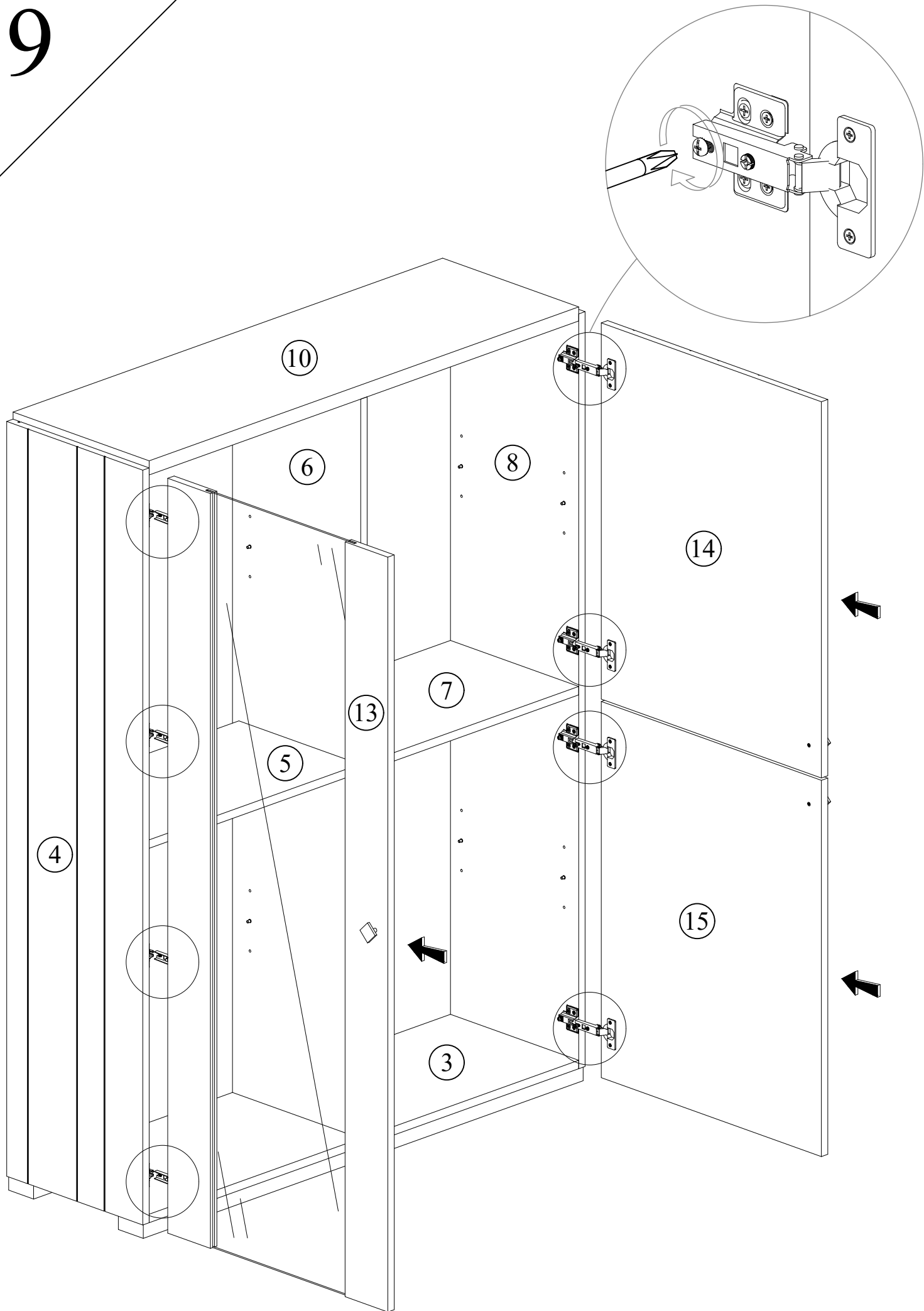

10

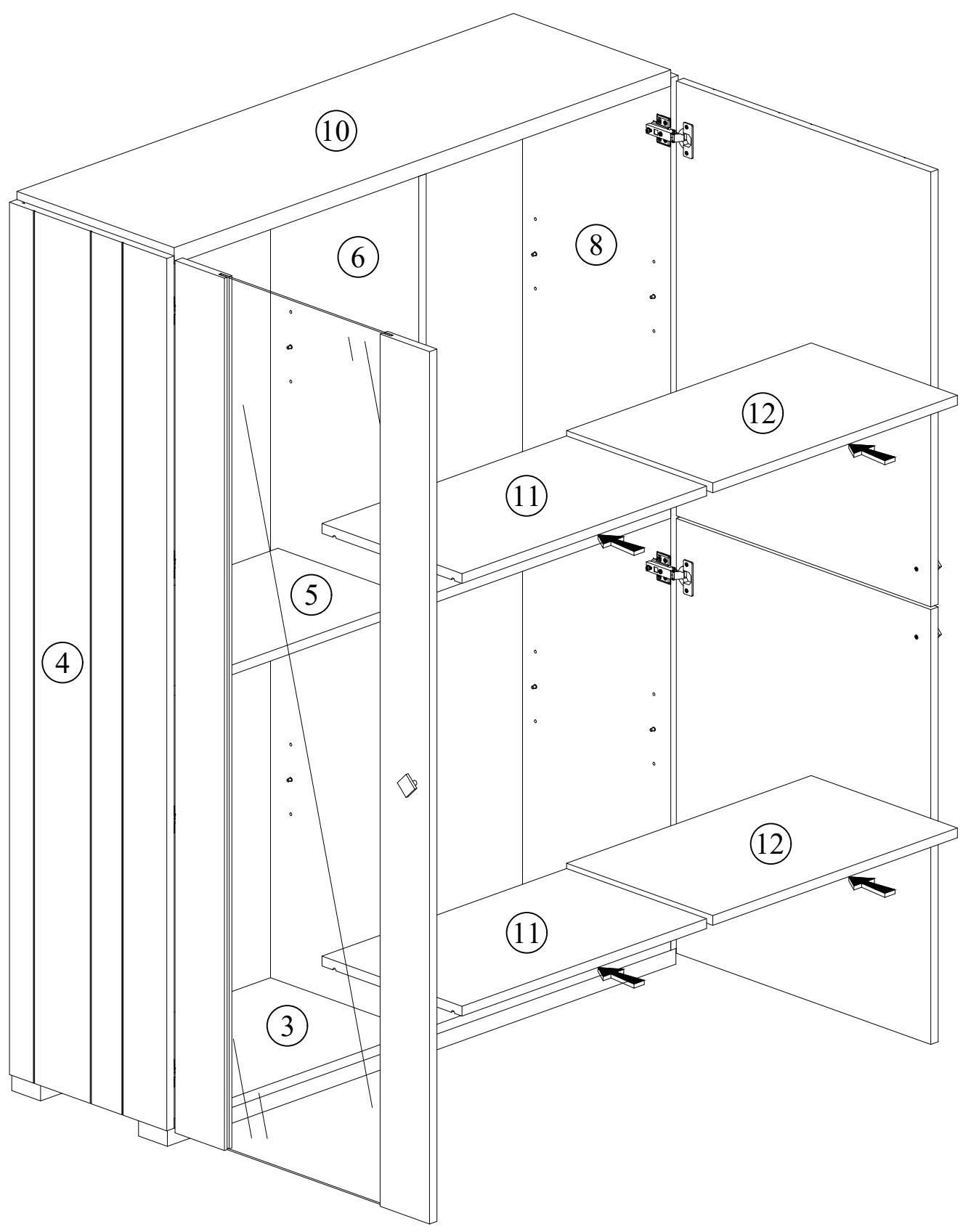

Reglage Afstelling Adjusting

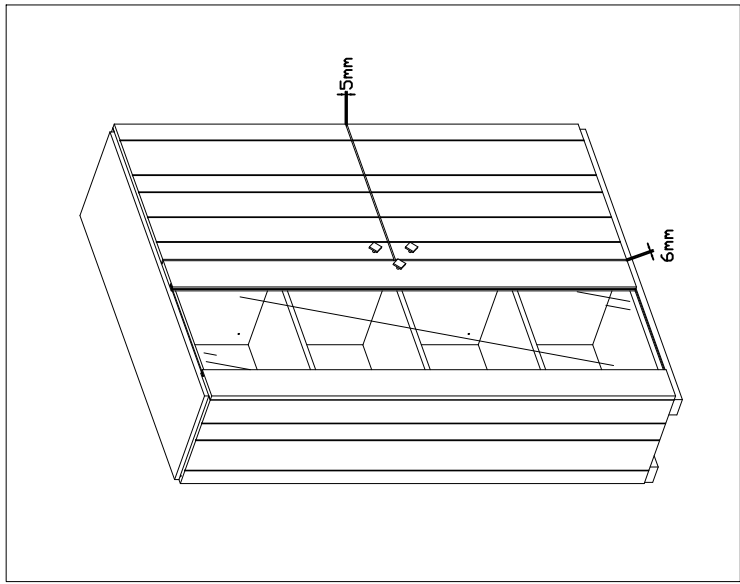
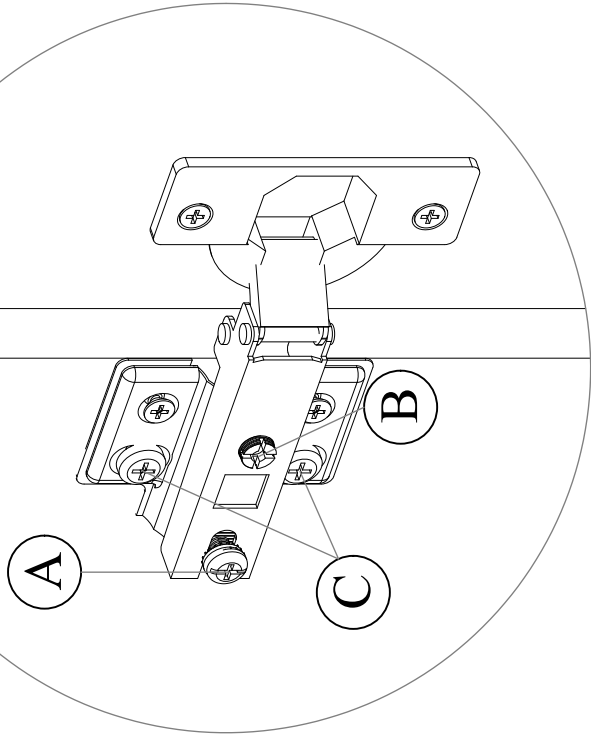

A

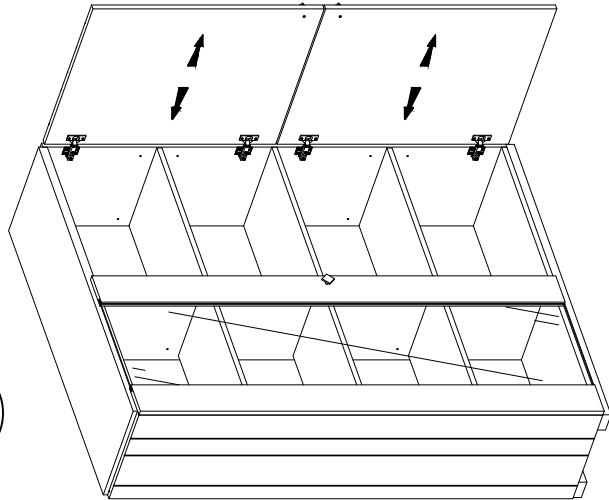

B

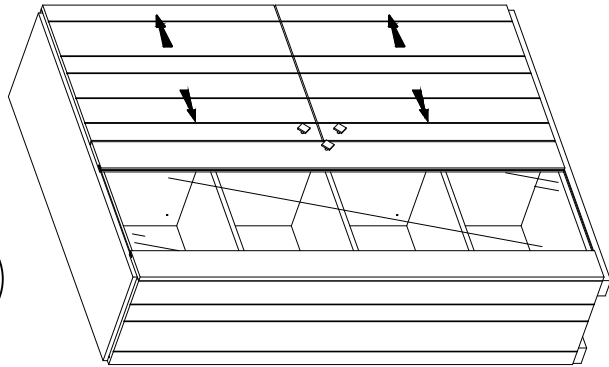

C

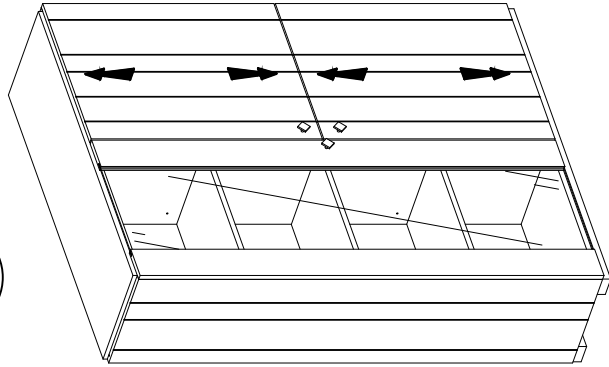

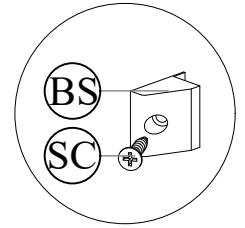
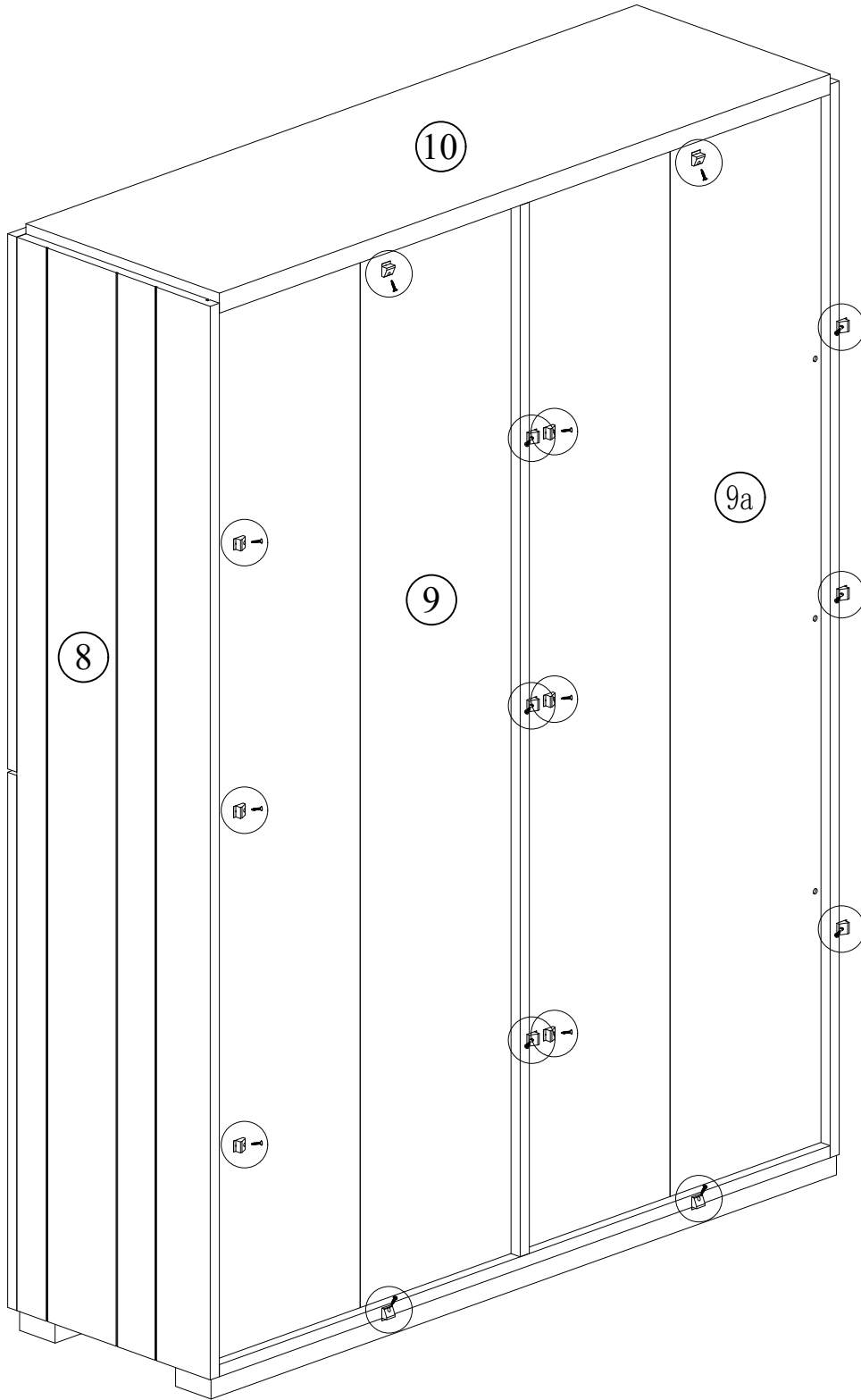

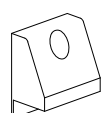
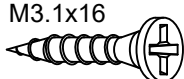
	BS	SC	16x
16x			

M3.1x16

Onderhoud - Entretien - Maintenance

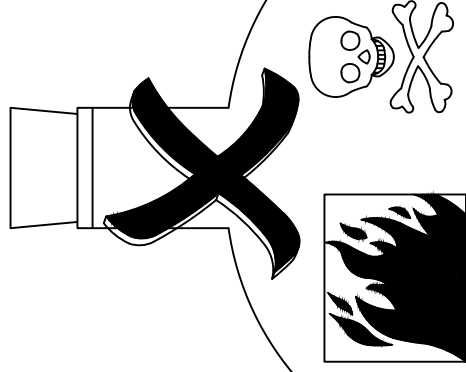

Oplosmiddel
Reinigingsmiddel
Verdunner
Chemische Producten
Boenwas

NL

Solvent
Detergent
Diluant
Produits chimiques
Cirage

FR

Solvent
Cleaner
Thinner
Chemical Products
Wax

GB

Onderhoud: met licht vochtige doek reinigen hierna direct droog wrijven. Vocht op het bovenblad direct opnemen. De meubels zijn niet voor vochtige ruimten bestemd. Gebruik nooit Oplosmiddel, reinigingsmiddel, verdunner, chemische producten of boenwas. Montage tekening opbergen. Voor Service na verkoop, ga naar uw leverancier met deze montage handleiding.

NL

Entretien: utilisez un chiffon légèrement humide et séchez aussitôt. Toute trace de liquide doit être en levé immédiatement. Meuble inadapté aux pièces humides. N' utilisez jamais du solvant, détergent, diluant, produits chimiques ou cirage. Notice du montage à conserver. Pour tous service l'apres-vente, rendez-vous au magasin avec cette notice.

FR

Maintenance: clean with slightly wet moistened cloth, wipe dry immediately. Wipe off wetness at once. Not suited for humid locations. Never use Solvent, cleaner, thinner, chemical products or wax. Retain manual instruction. For the after sales, go back to the shop with this assembly instruction.

GB

Dienst na verkoop

Beste klant,

Wij danken u voor de aankoop van dit meubel.

Ondanks de zorg die wij besteden aan de productie en verpakking van onze meubelen, kan het voorkomen dat er iets ontbreekt of beschadigd is.

Is dit het geval vragen wij u om via bijgaand formulier uw DNV te melden aan de winkel waar u uw meubel heeft aangekocht.

Bij schade vragen wij u ook om volgende:

- 1) een foto van het complete meubel (onderdeel)
- 2) een detailfoto van het probleem

Op die manier kunnen wij u zo vlug mogelijk helpen om uw probleem op te lossen.

Met vriendelijke groet,

Service après vente

Cher client,

Nous vous remercions pour l'achat de ce meuble.

Malgré tout les soins que nous consacrons à la production et le conditionnement de nos meubles, il est possible que quelque chose est manquant ou endommagé.

Si c'est le cas, nous vous demandons d'utiliser le formulaire ci-joint pour déclarer votre plainte au magasin où vous avez acheté vos meubles.

En cas de dommages, nous vous demandons également de prendre les photos suivants et de nous les envoyer:

- 1) une photo du mobilier complet (partie)
- 2) une photo de détail du problème

De cette façon, nous pouvons vous aider le plus vite possible afin de résoudre votre problème.

Sincèrement,

FORMULIER DNV - FORMULAIRE SAV

Terug te sturen naar uw winkel

A renvoyer à votre magasin

DATUM./DATE :

UW GEGEVENS / VOS DONNEES

NAAM/NOM :

ADRES/ADRESSE :

E-MAIL:

TEL./GSM

GEGEVENS OVER HET PROBLEEM - DONNEES SUR LE PROBLEME

Datum aankoop / Date d'achat:

Naam model en meubelonderdeel
Nom modèle et partie du meuble

Onderdeelnr. of colli nr.
(zie het montageplan)
N° de pièce ou coli
(voir le plan de montage)

Kleur of stof
Couleur ou tissu

Digitale foto's in bijlage
Photos digitales en annexe

JA/OUI - NEE/NON

Gedetailleerde omschrijving van het probleem :

Description détaillée du problème: