



Owen

Bibliotheek
Bibliothèque
Library



Opbouw met 2 personen
Montage par 2 personnes
Assembling by 2 persons

Gebruik deze handleiding van begin tot einde voor het probleemloos monteren van uw aangekocht meubel aub.

Veillez bien suivre nos instructions ci-après lors du montage de votre meuble. Merci.

Please use the manual from the beginning until the end to assemble your newly bought furniture without troubles.

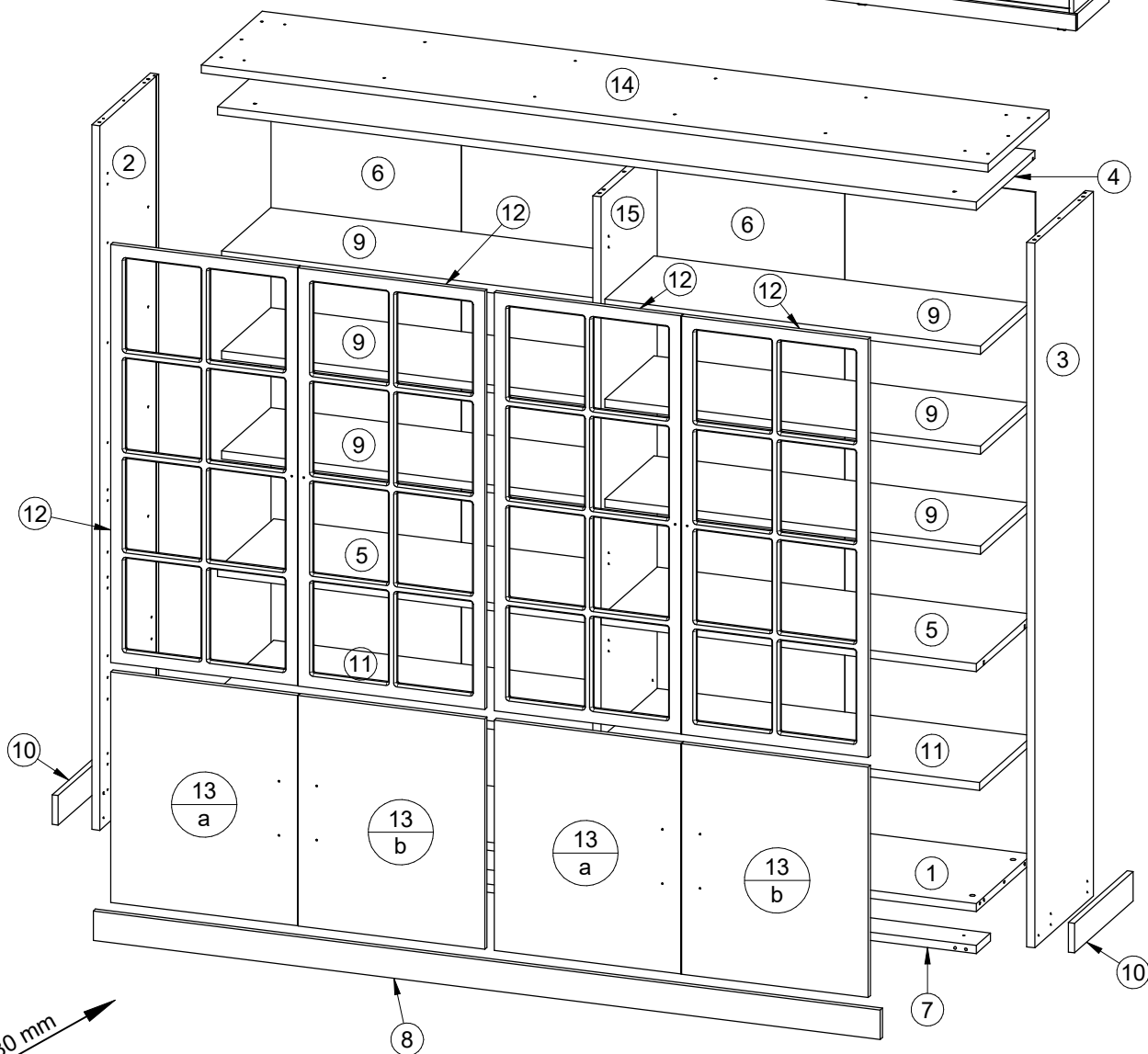
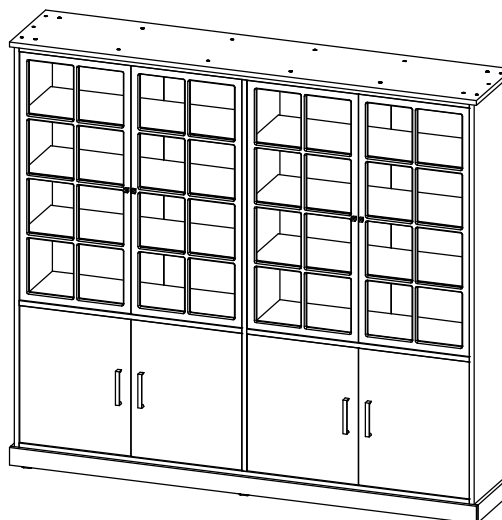

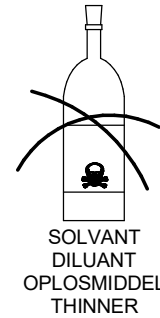
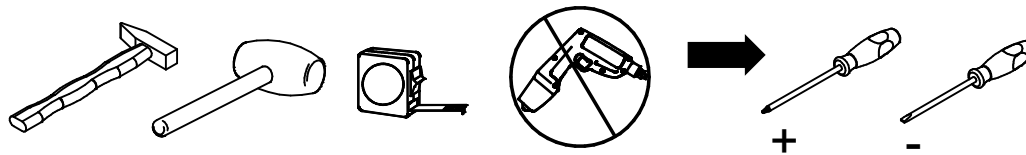

(FR) Entretien: utilisez un chiffon légèrement humide et séchez aussitôt. Toute trace de liquide doit être enlevé immédiatement. Meuble inadapté aux pièces humides. N' utilisez jamais du solvant, détergent, diluant, produits chimiques ou cirage. Notice du montage à conserver. Pour tous service apres-vente, rendezvous au magasin avec cette notice.





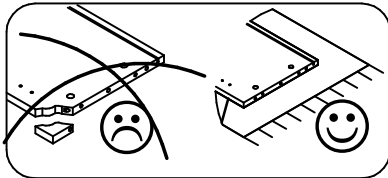



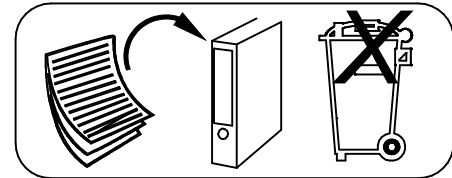

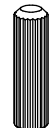









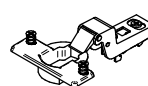

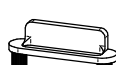
(GB) Maintenance: clean with slightly wet moistened cloth, wipe dry immediately. Wipe off wetness at once. Not suited for humid locations. Never use solvent, cleaner, thinner, chemical products or wax. Retain manual instruction. For the after sales, go back to the shop with this assembly instruction.

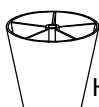
(NL) Onderhoud: met licht vochtige doek reinigen hierna direct droog wrijven. Vocht op het bovenblad direct opnemen. De meubels zijn niet voor vochtige ruimten bestemd. Gebruik nooit oplosmiddel, reinigingsmiddel, verdunner, chemische producten of boenwas. Montage tekening opbergen. Voor service na verkoop, ga naar uw leverancier met deze montage handleiding.



Made in Belgium

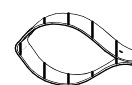
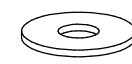
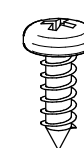

A  8x30 26x	AAB  13x	AAD  24x	AR  8x	B  13x	BAA  5x55 3x	BM  40x40x15 5x
BO  8x	BP7  8x	DHe  16x	DI  8x	EK  4x	EZe  8x	GC  4x
BAP  4x	PA  7x	PU90  H90 3x	QQ  3.5x17 4x	JQ  4x	TJ  M4x23 4x	WN  5x45 12x
XX  7x50 6x	YX  4x16 36x	YU  4x35 15x	SAF = Compleet Complete			
		 1x	 2x	 1x		

KU1 = Compleet-Complete

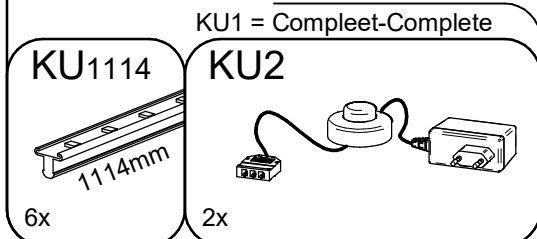

TAZ1 = Compleet-Complete

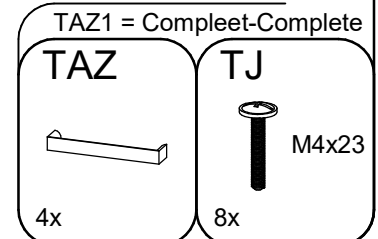

1

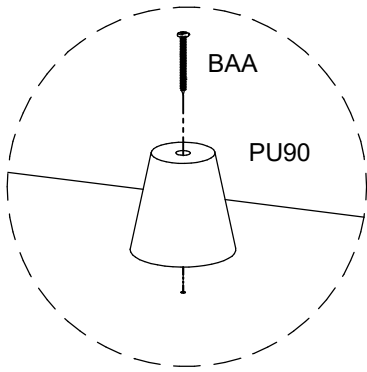
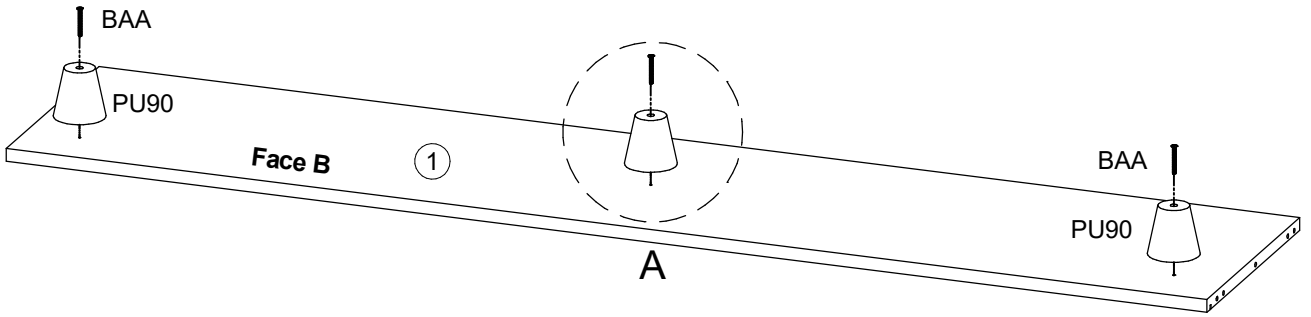

DETAIL A

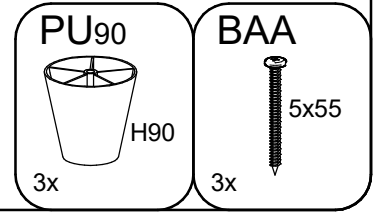

2

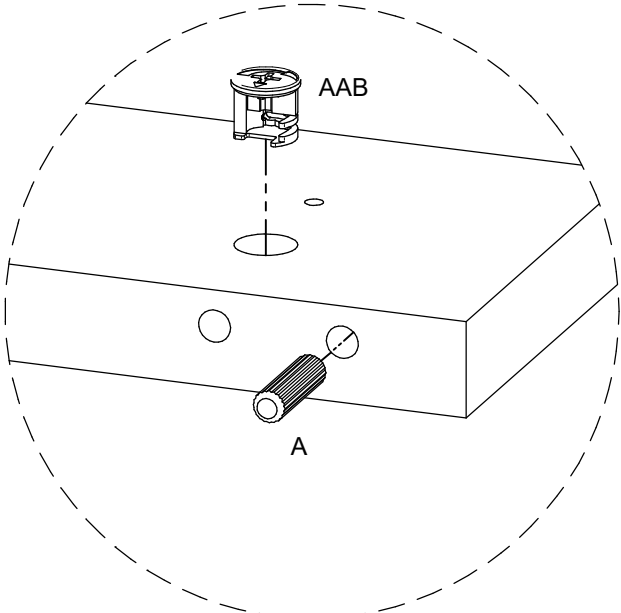
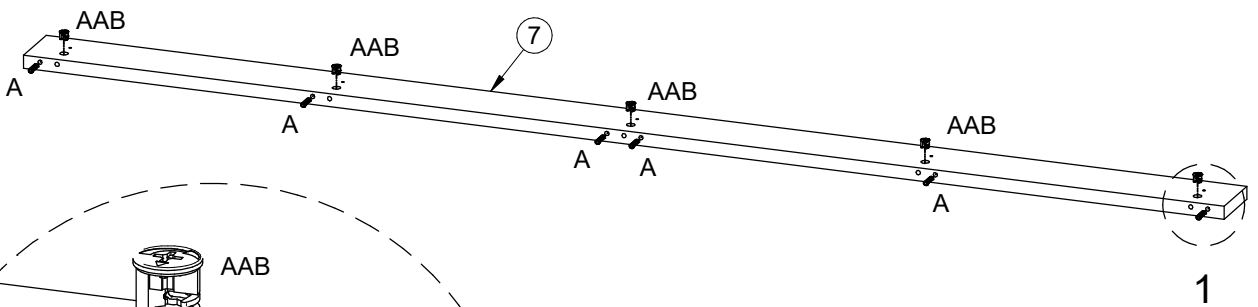

DETAIL 1

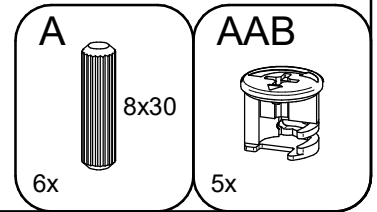

3

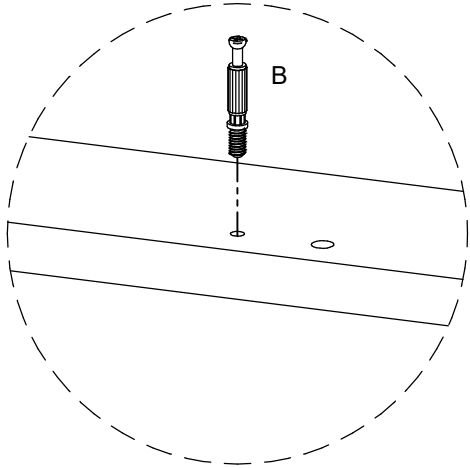
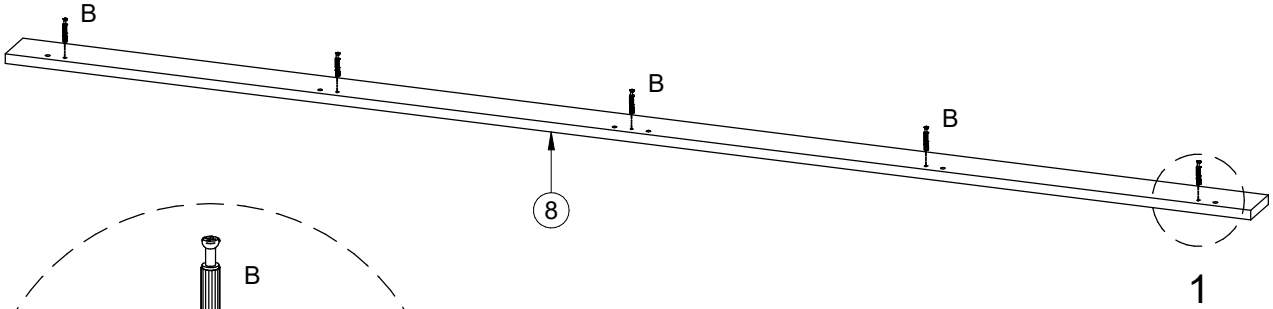
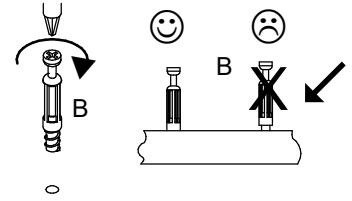

DETAIL 1

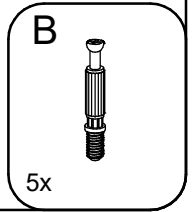

4

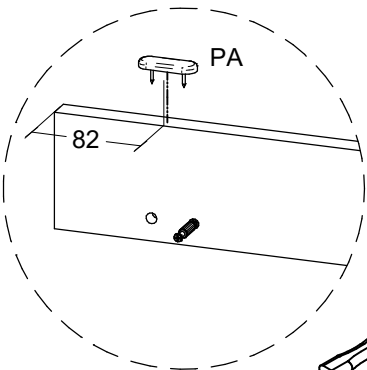
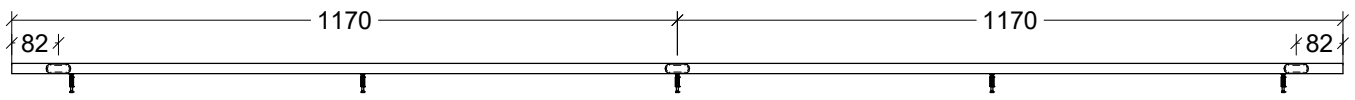
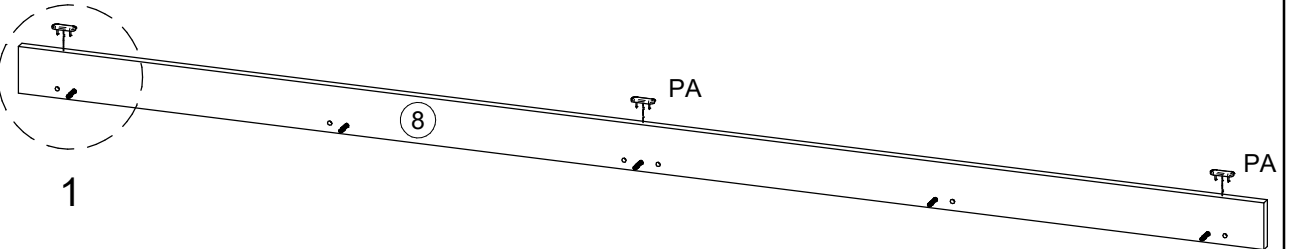

DETAIL 1

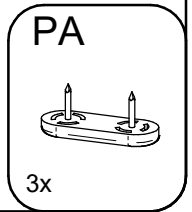

5

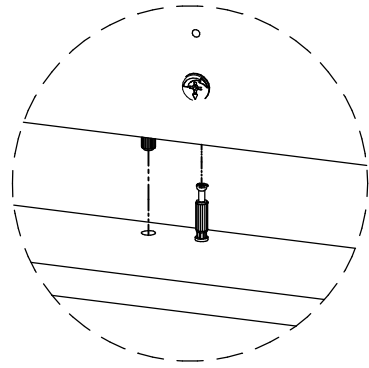
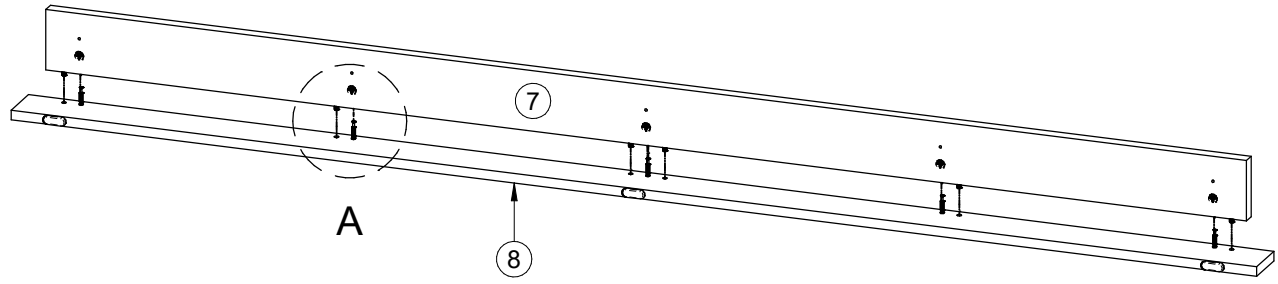

DETAIL A

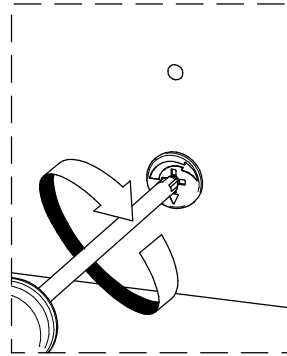

6

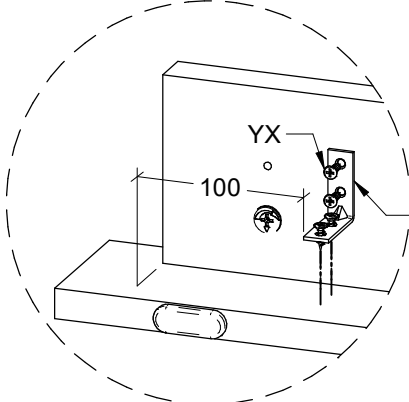
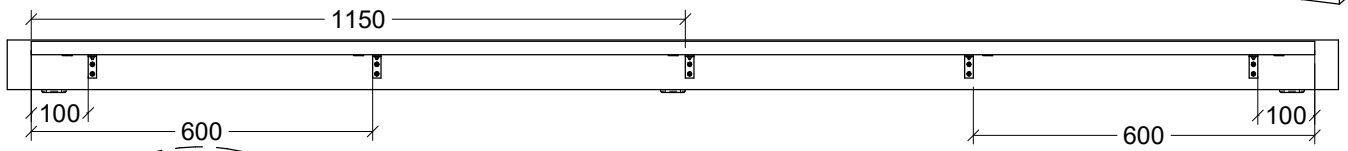
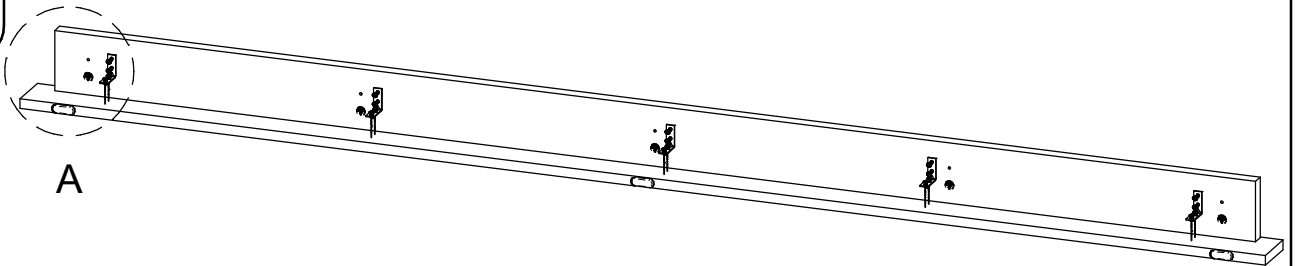

DETAIL A

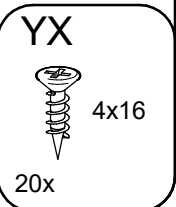
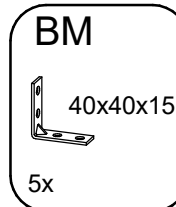
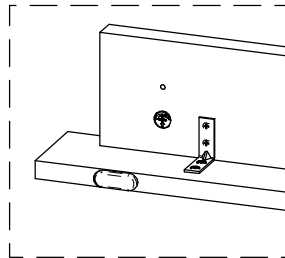

7

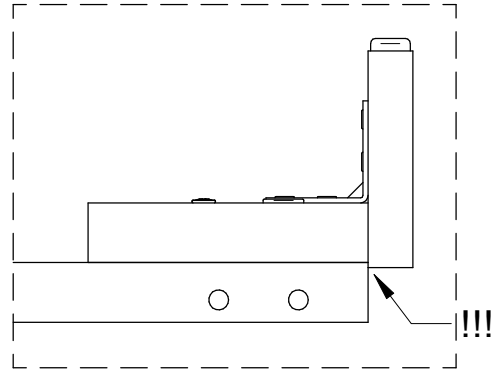
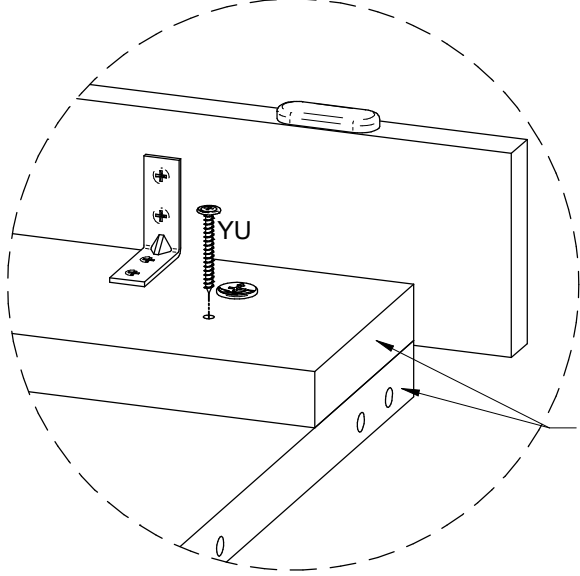
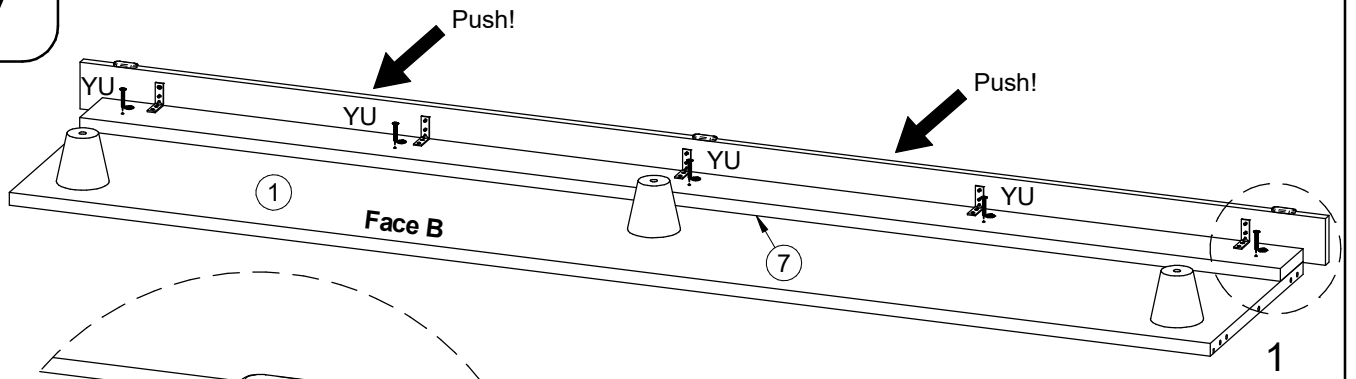

DETAIL 1

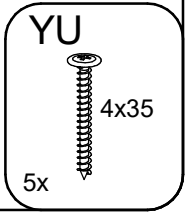

8

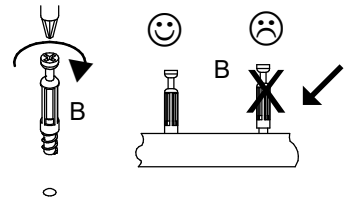
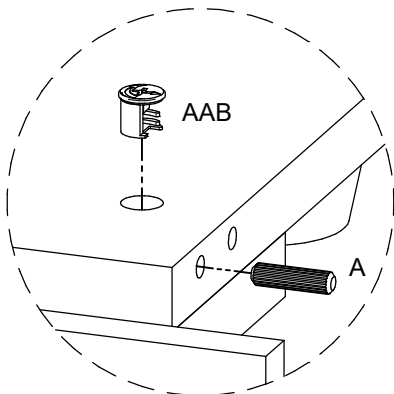
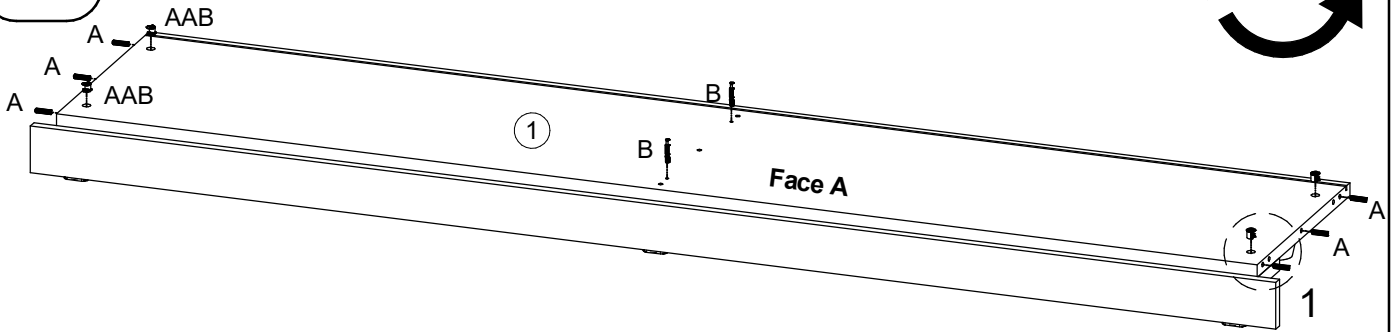

DETAIL 1

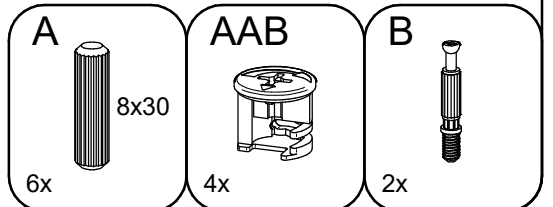

9

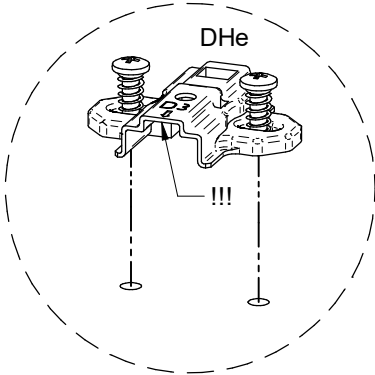
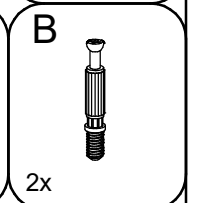
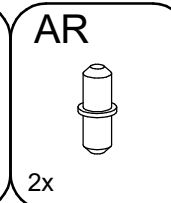
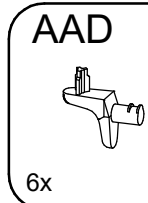
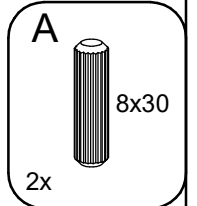
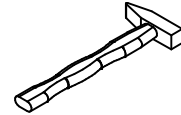
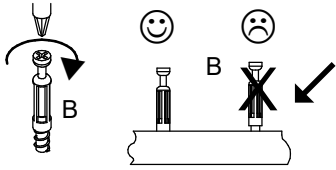
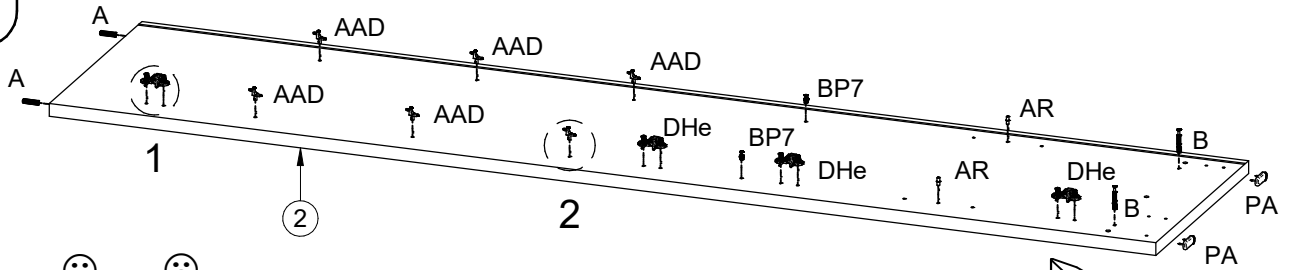

DETAIL 1

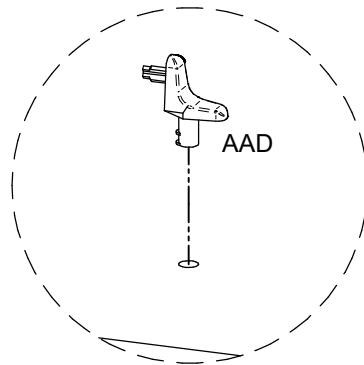

DETAIL 2

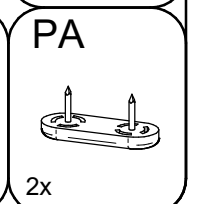
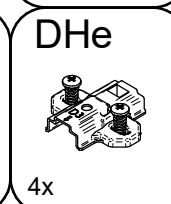
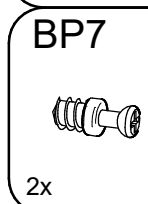

10

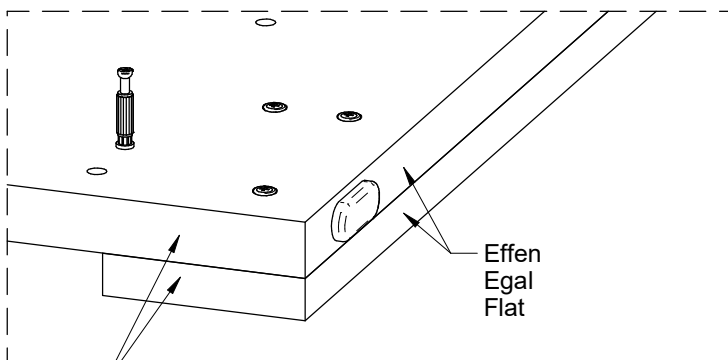
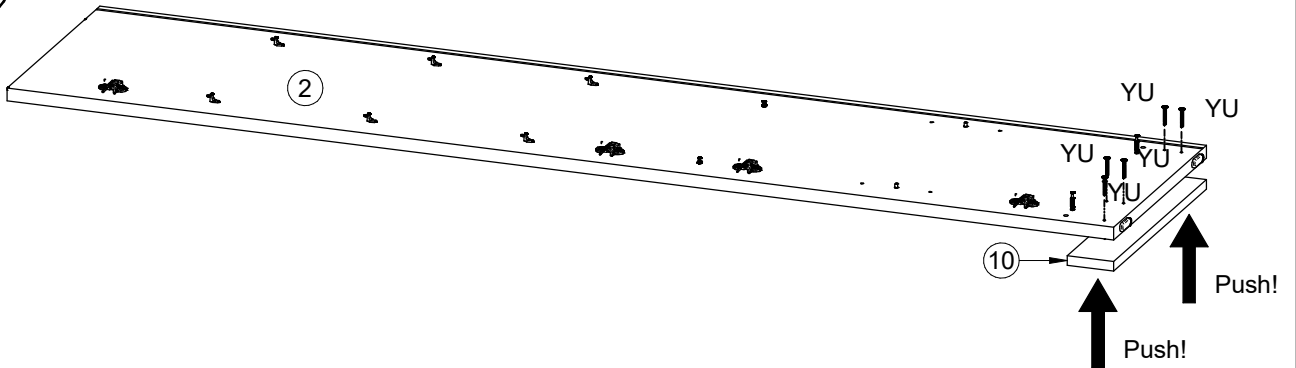

Effen
Egal
Flat

Effen
Egal
Flat

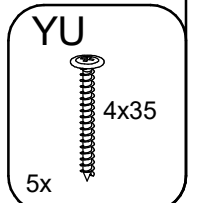

11

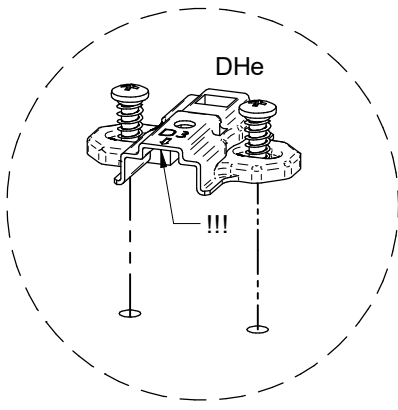
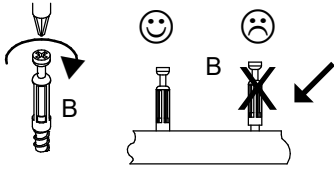
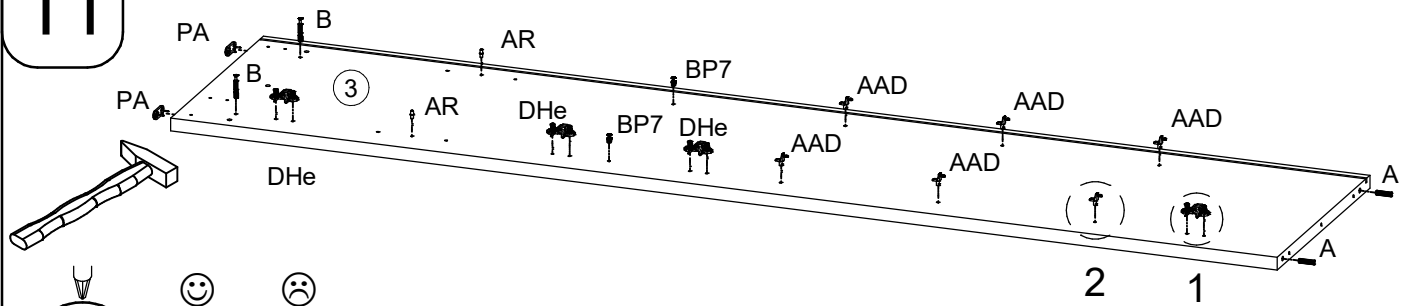

DETAIL 1

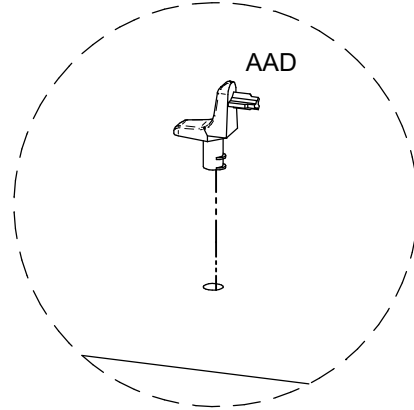

DETAIL 2

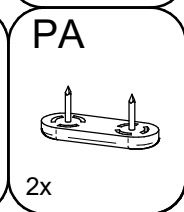
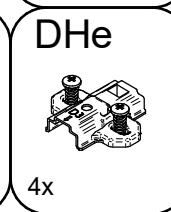
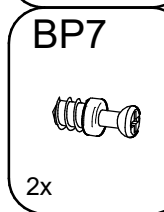
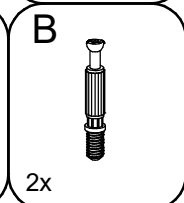
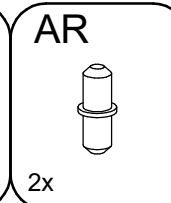
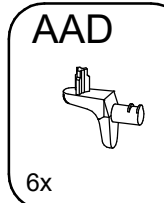
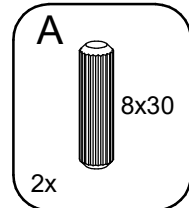

12

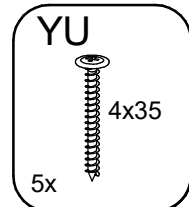
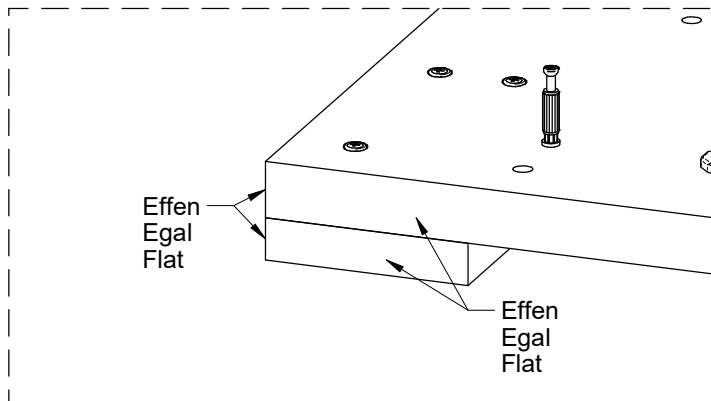
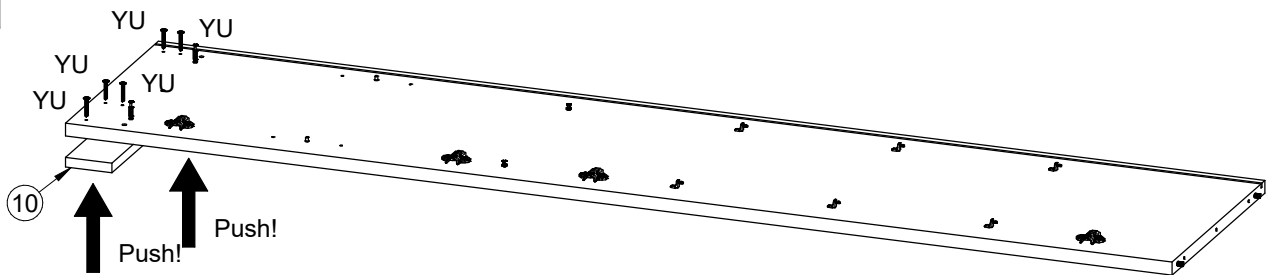

13

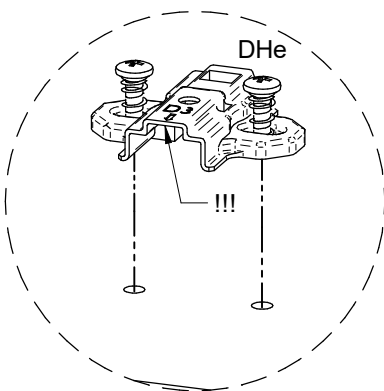
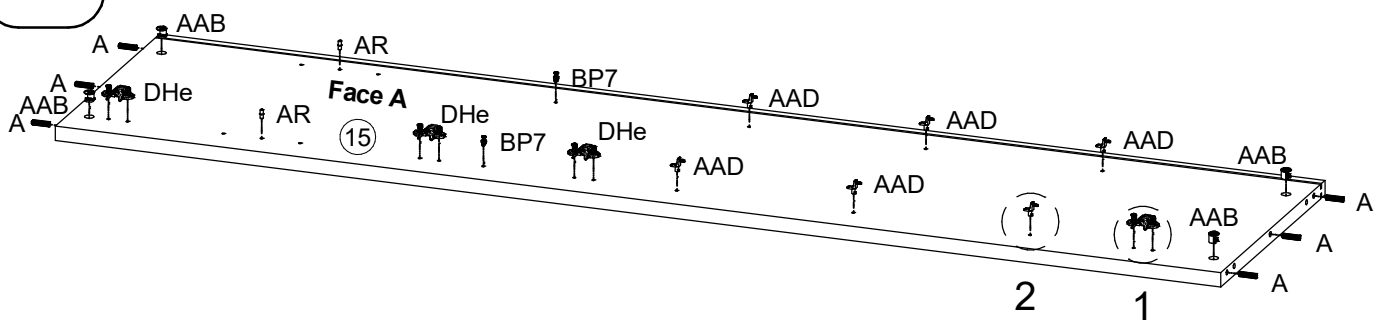

DETAIL 1

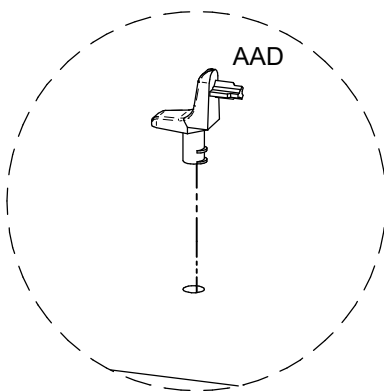

DETAIL 2

A 8x30 6x	AAB 4x	AAD 6x
AR 2x	BP7 2x	DHe 4x

14

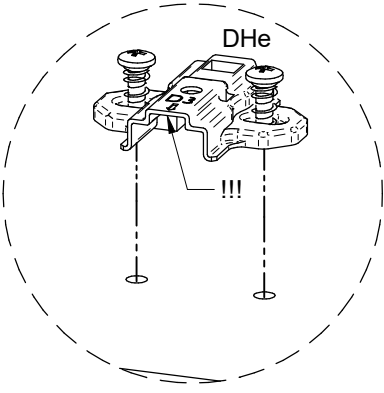
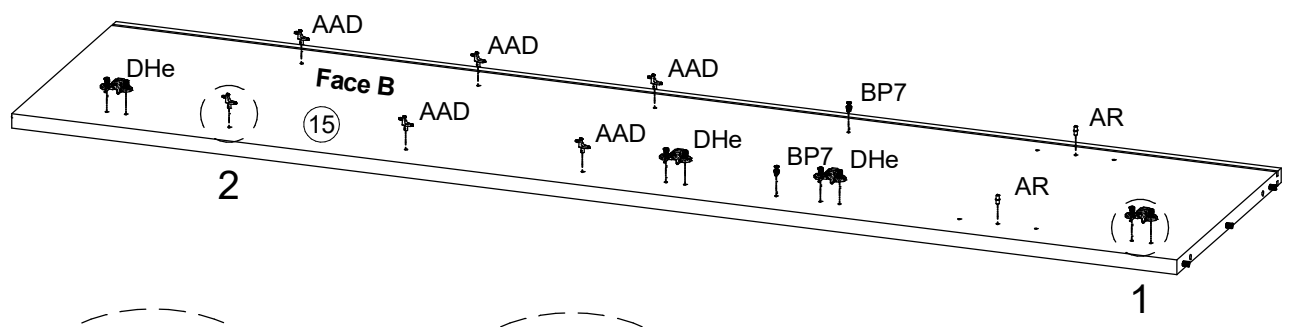
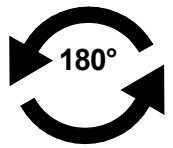

DETAIL 1

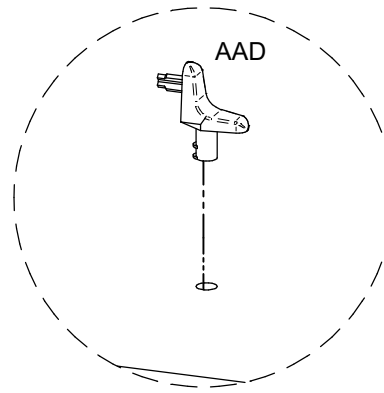

DETAIL 2

AAD 6x	AR 2x
BP7 2x	DHe 4x

15

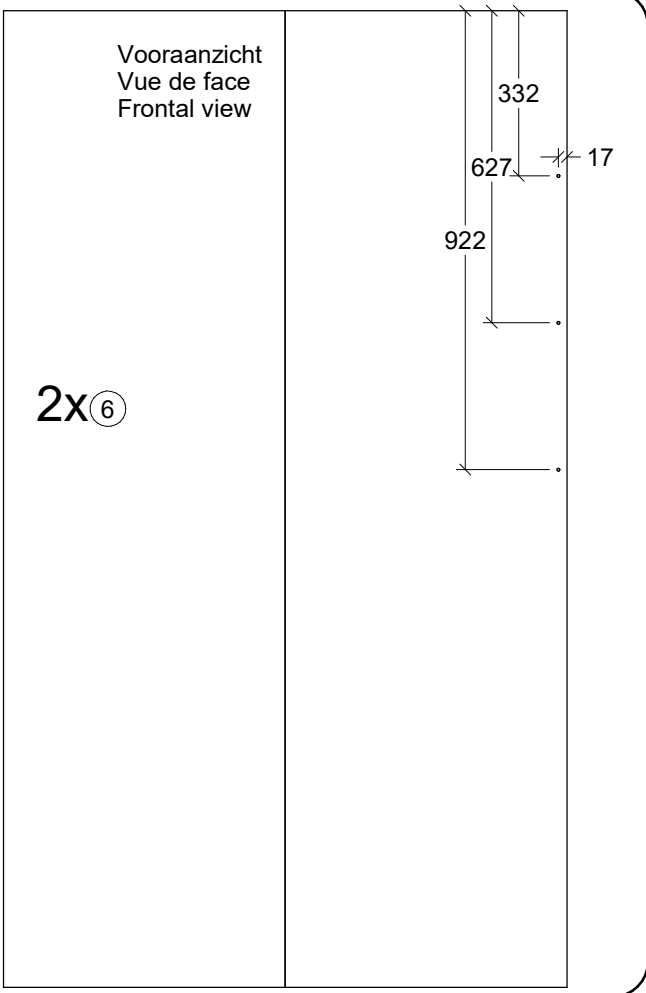
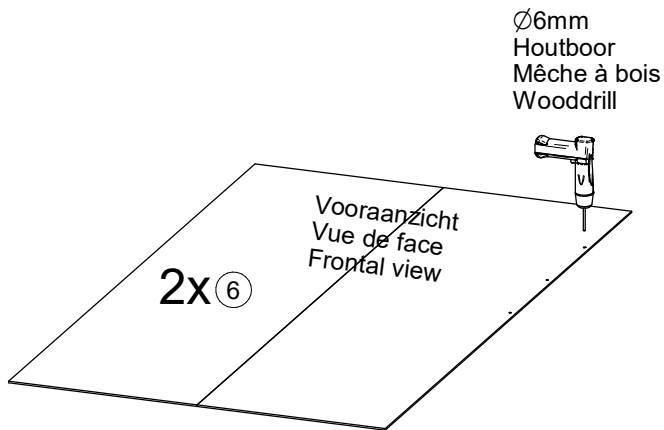

16

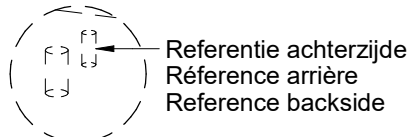
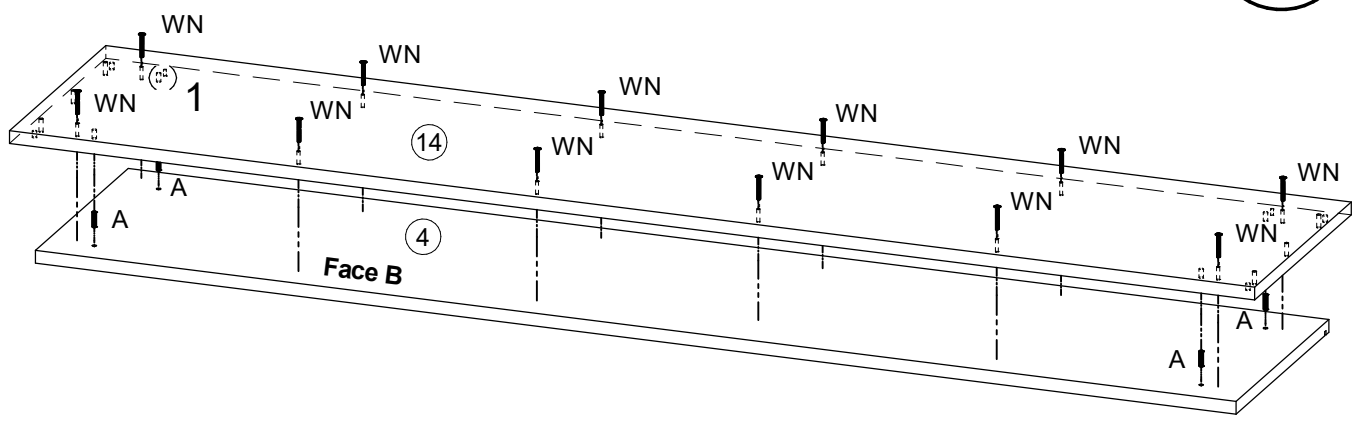
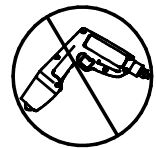

DETAIL 1

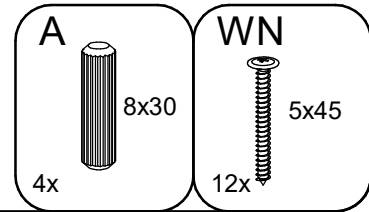

17

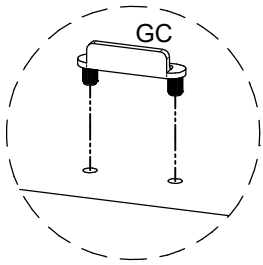
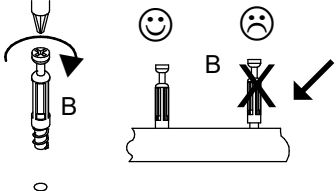
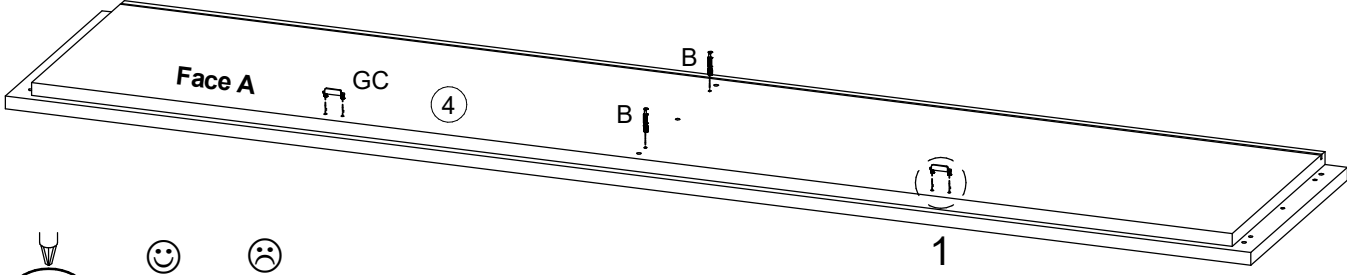
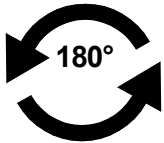

DETAIL 1

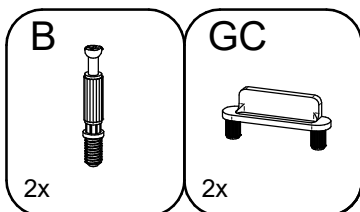

18

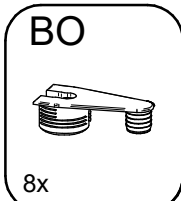
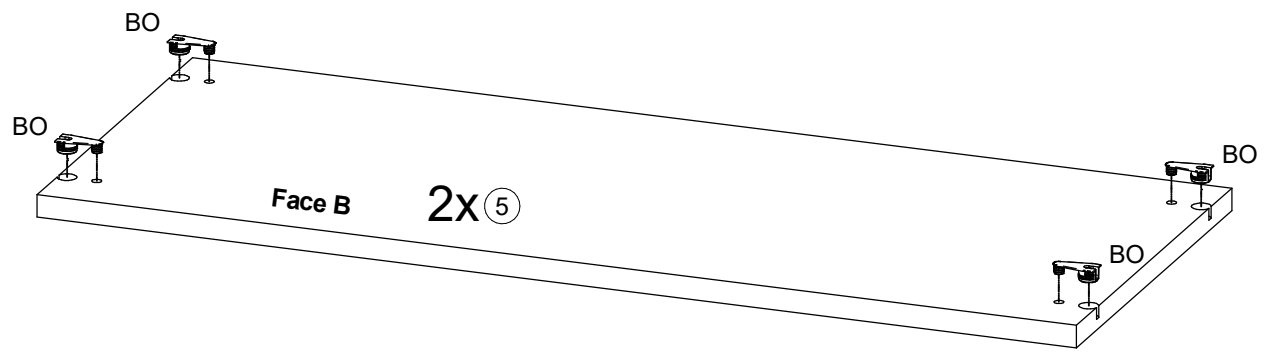

19

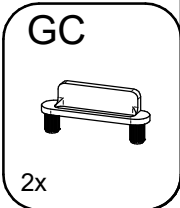
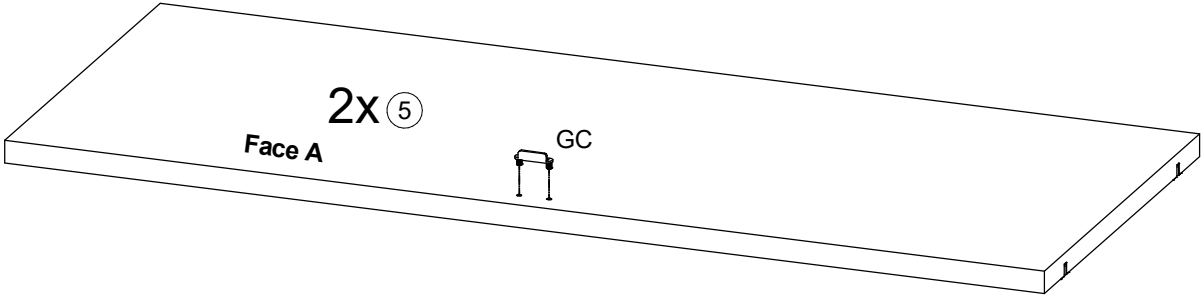
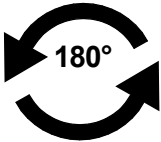

20

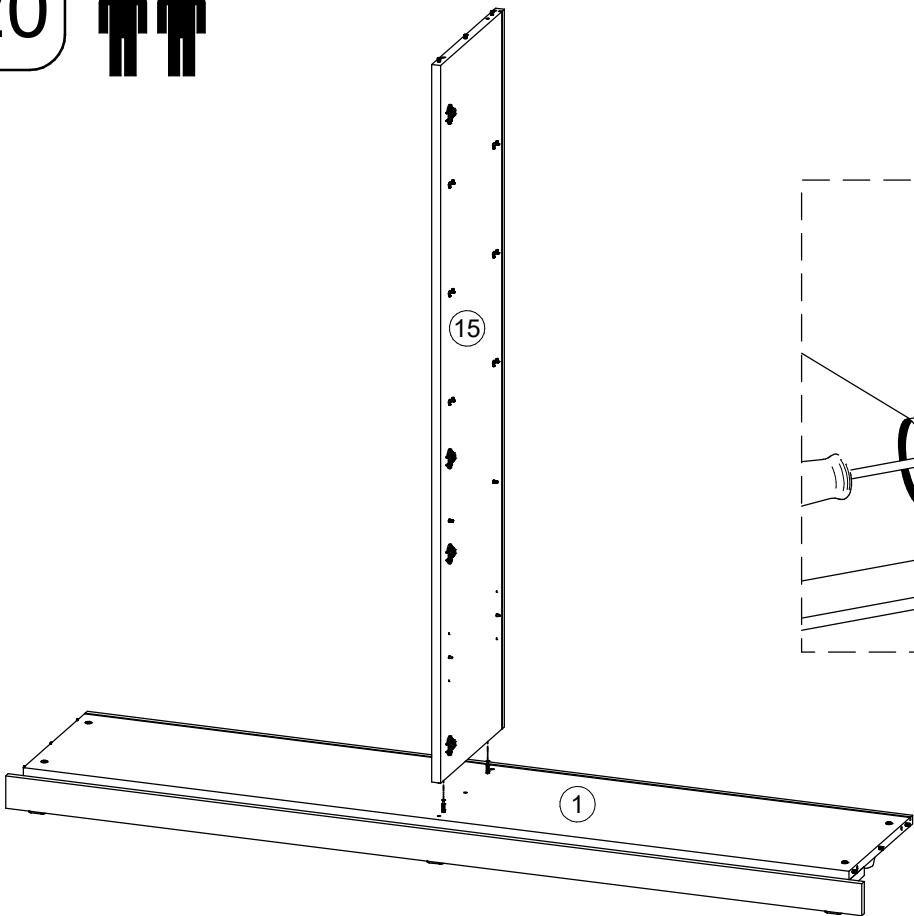

21

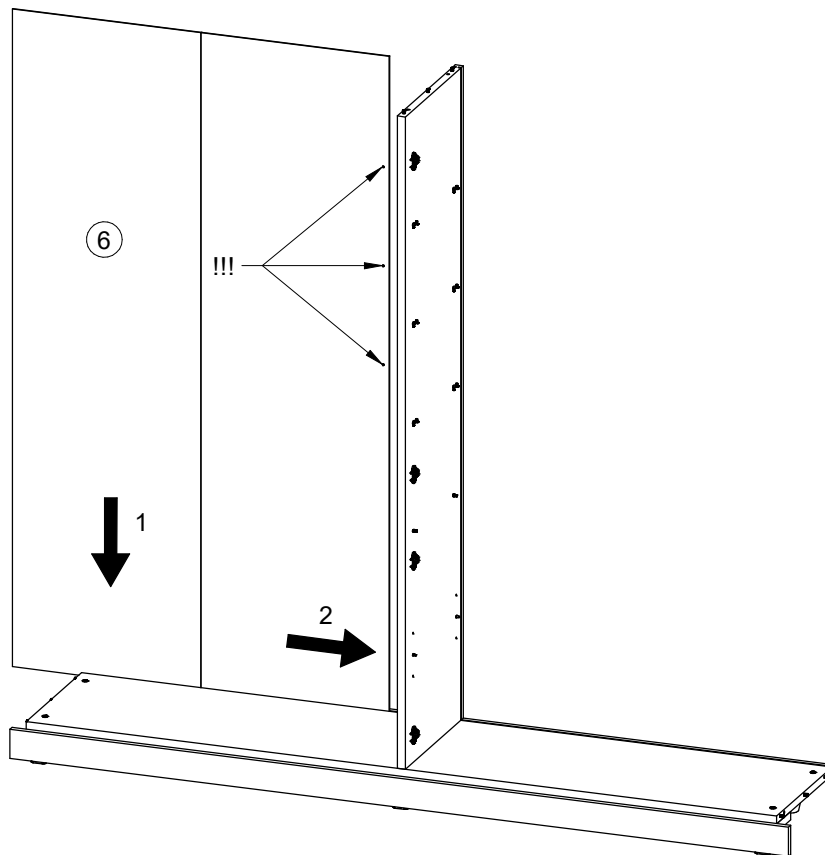
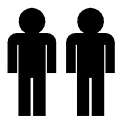

22

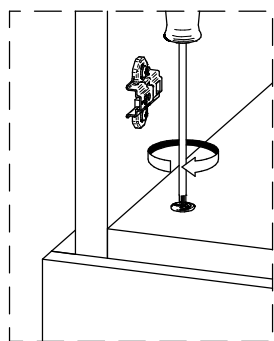
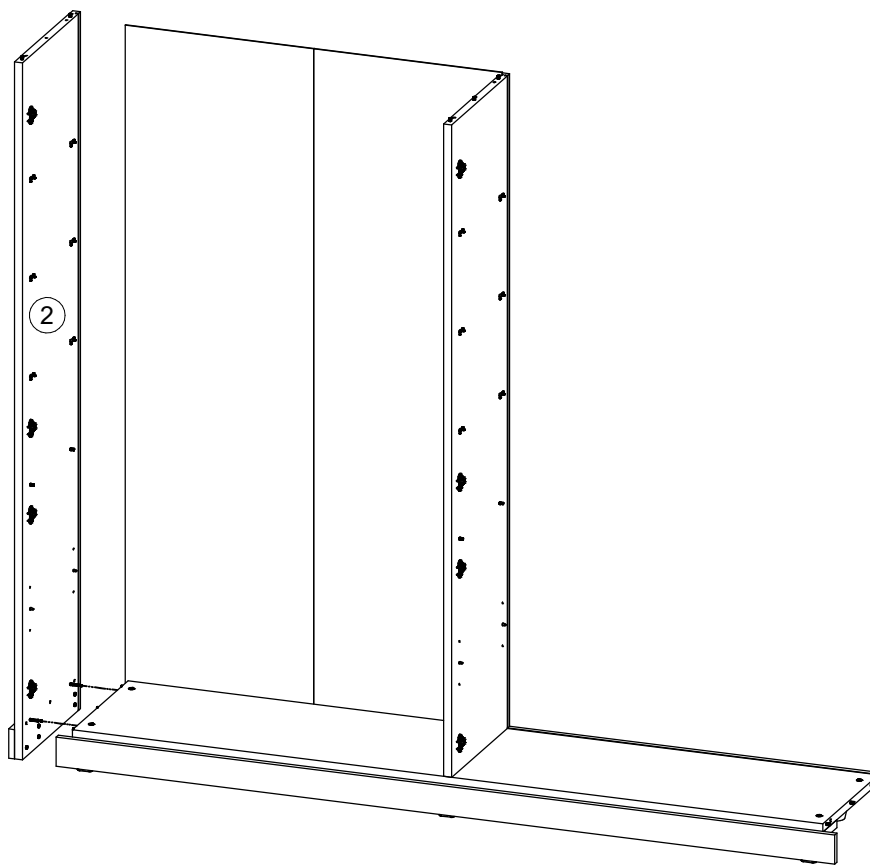

23

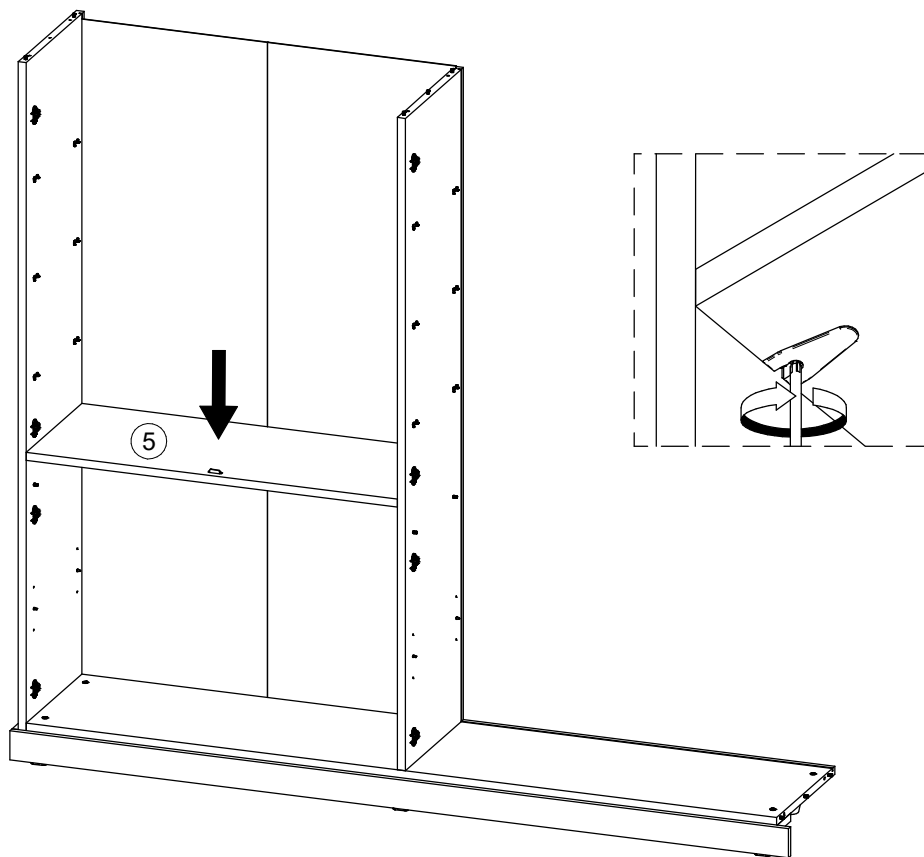
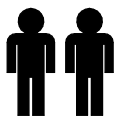

24

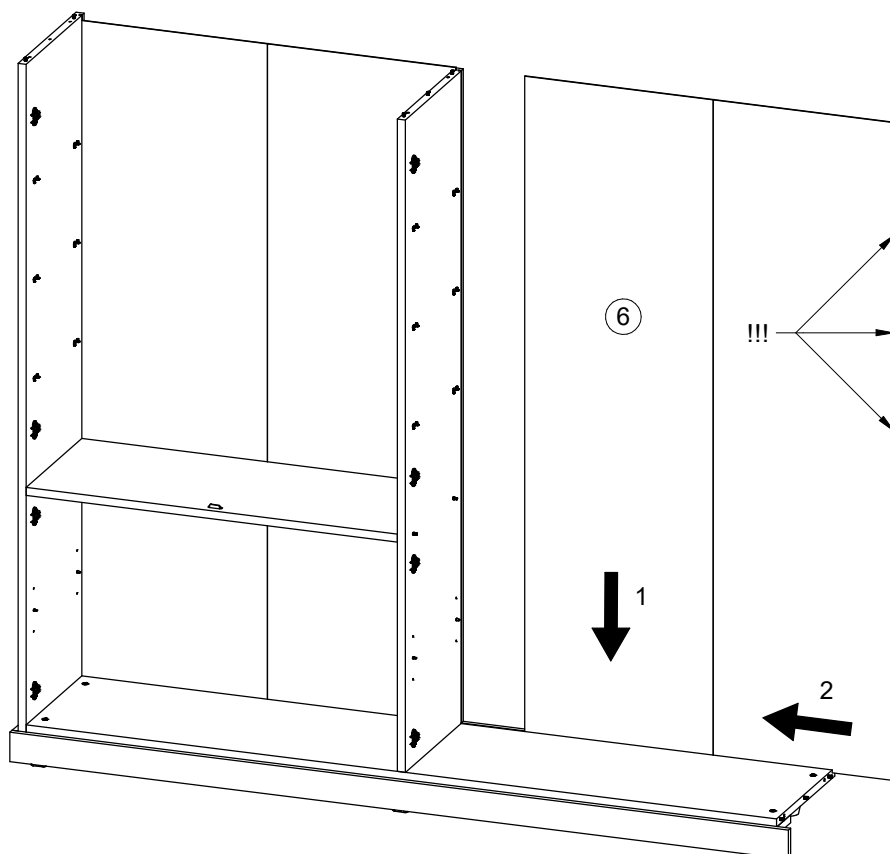

25

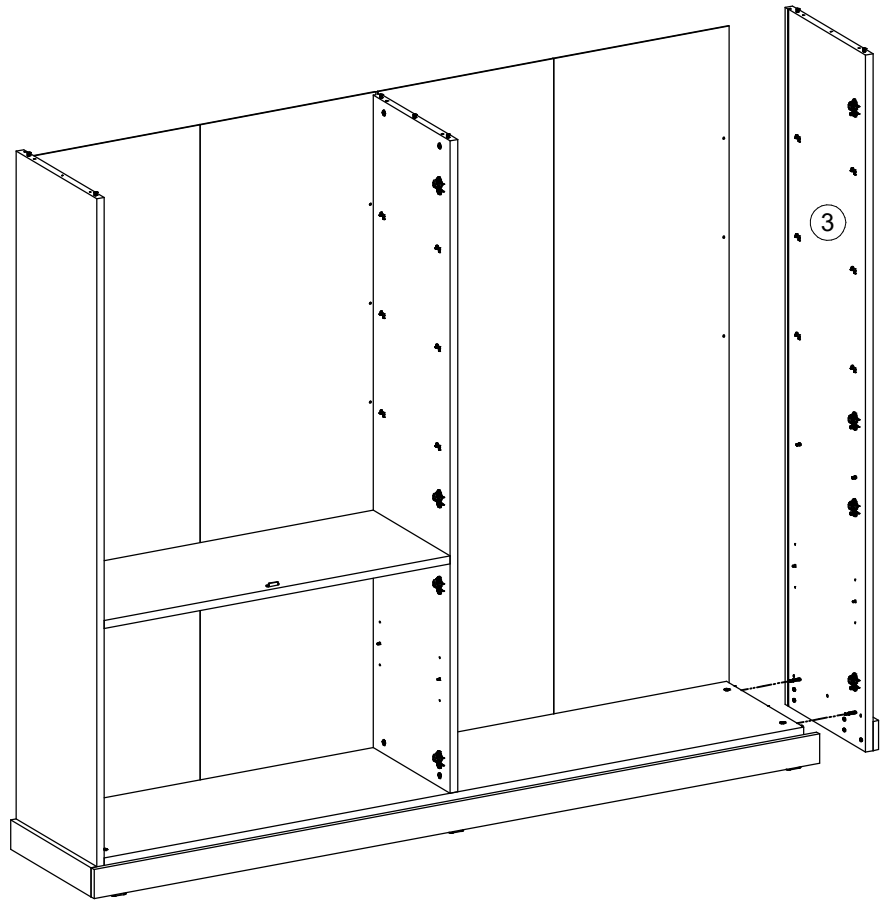
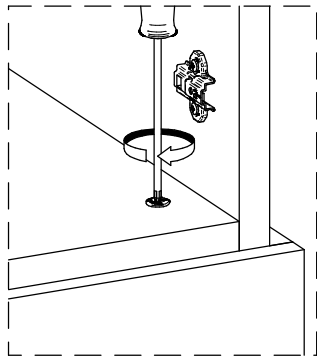

26

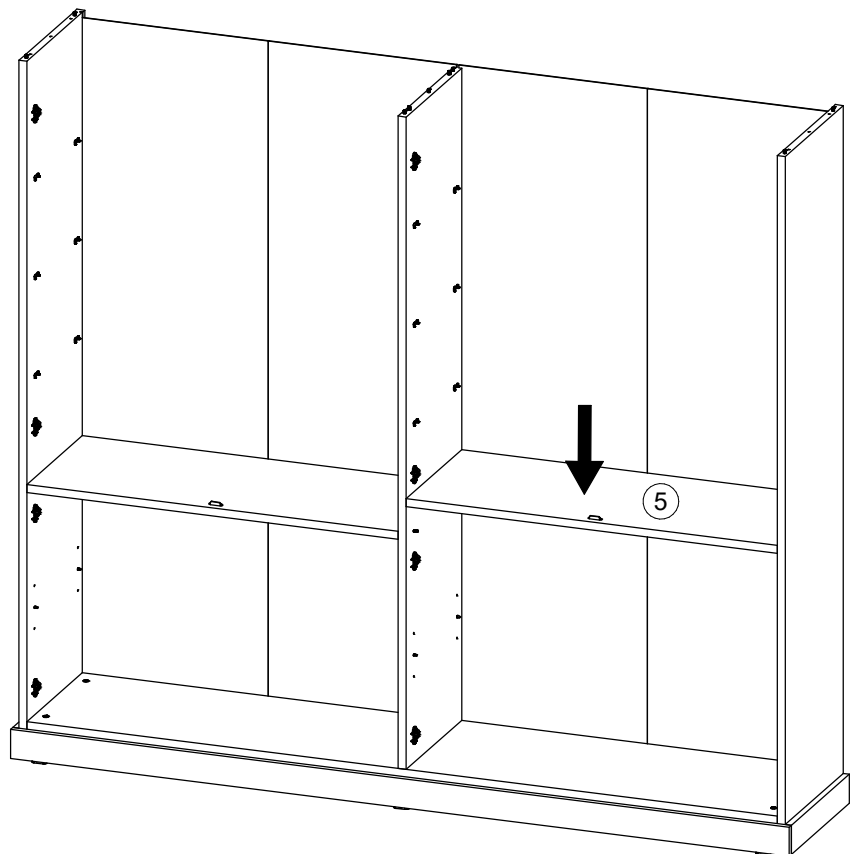
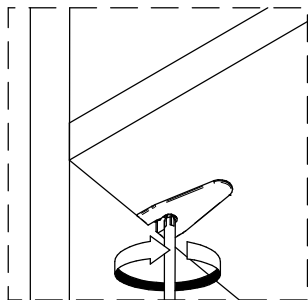

27

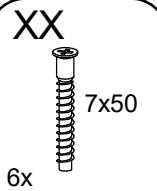
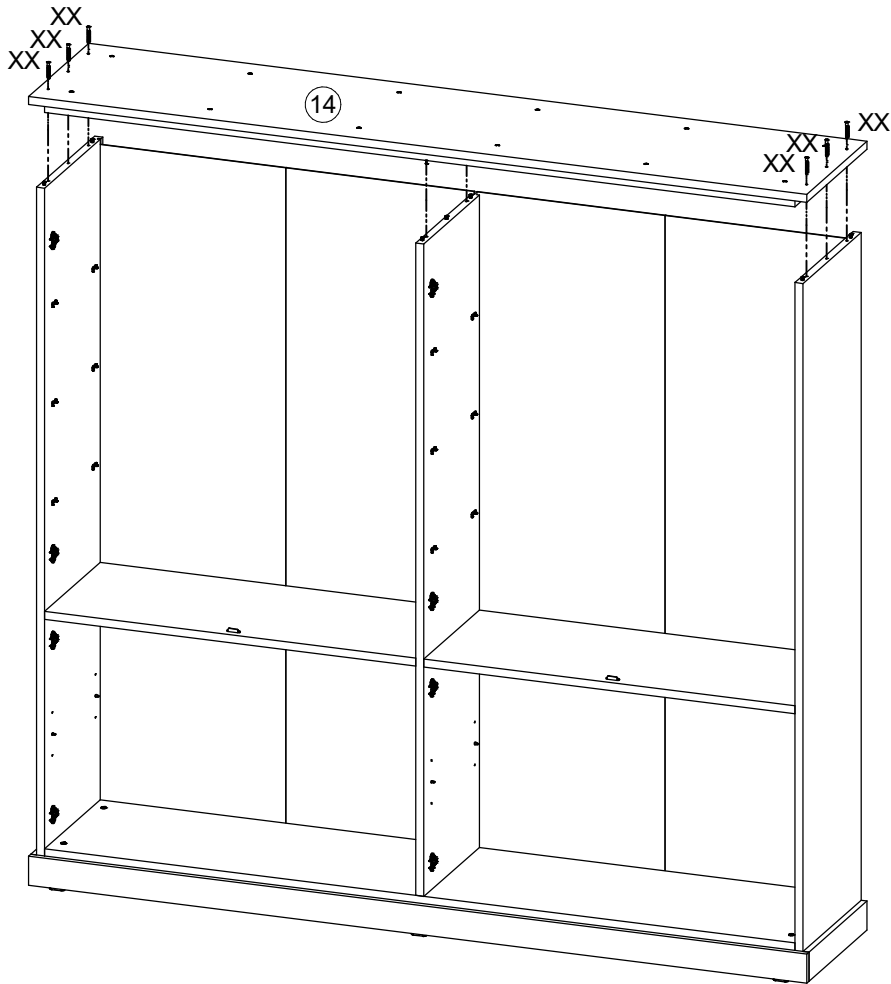

28

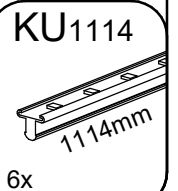
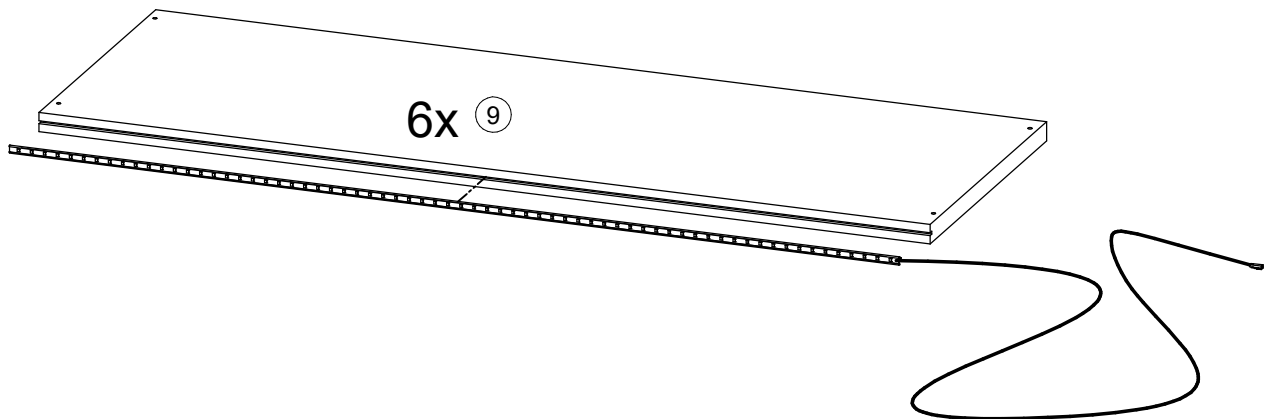

29

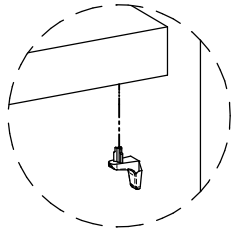
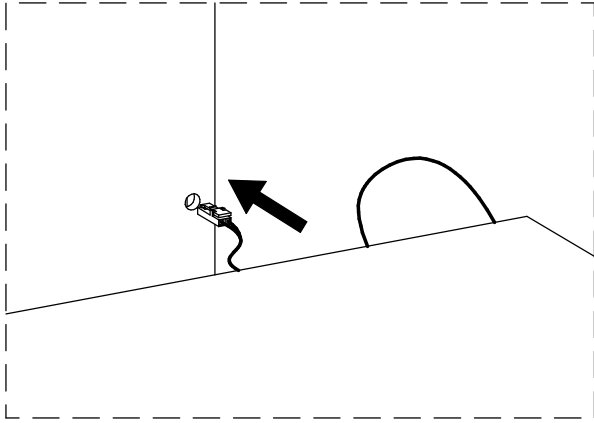

DETAIL 1

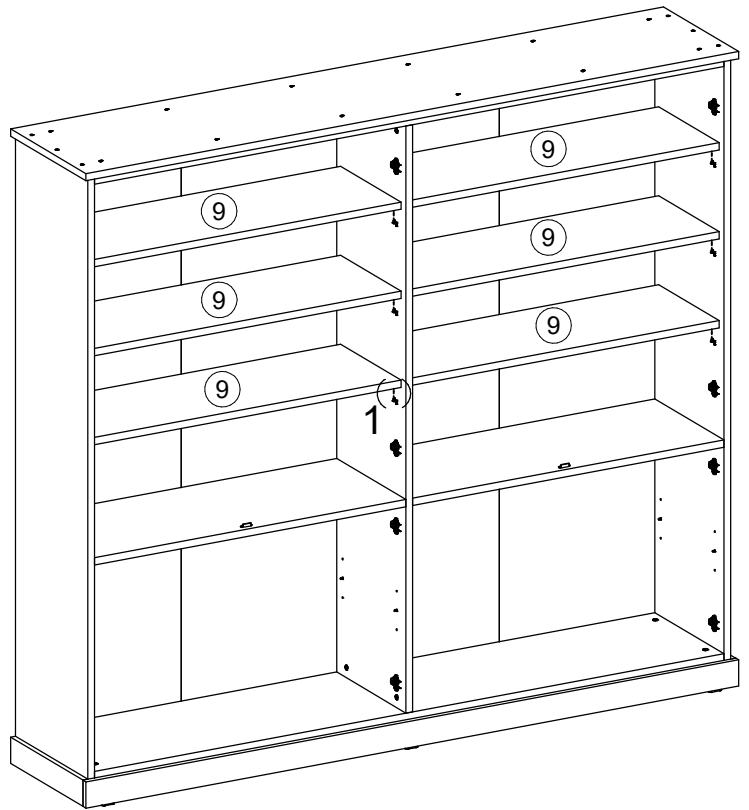

30

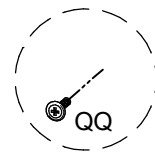
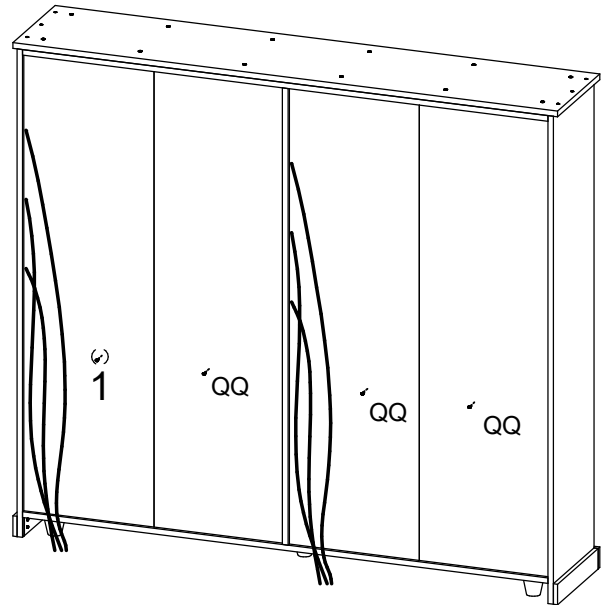
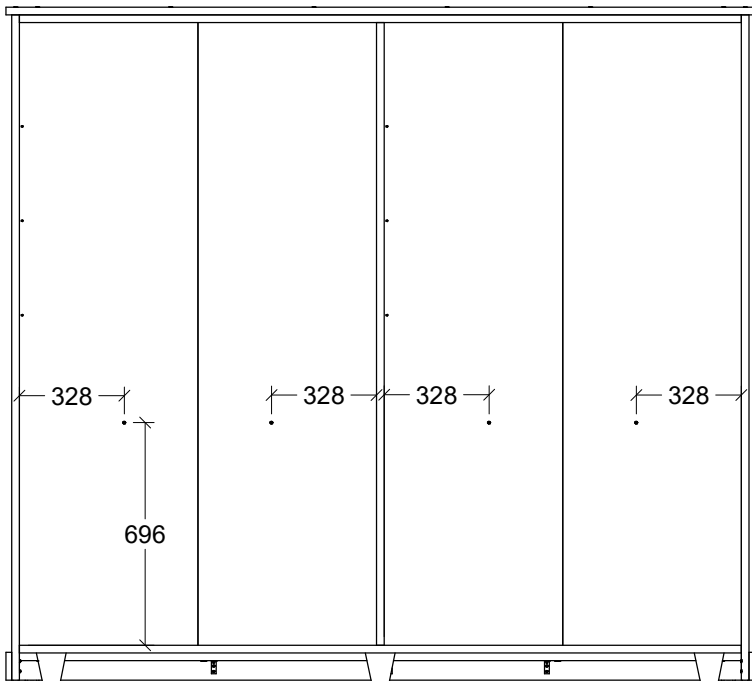

DETAIL 1

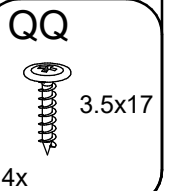

31

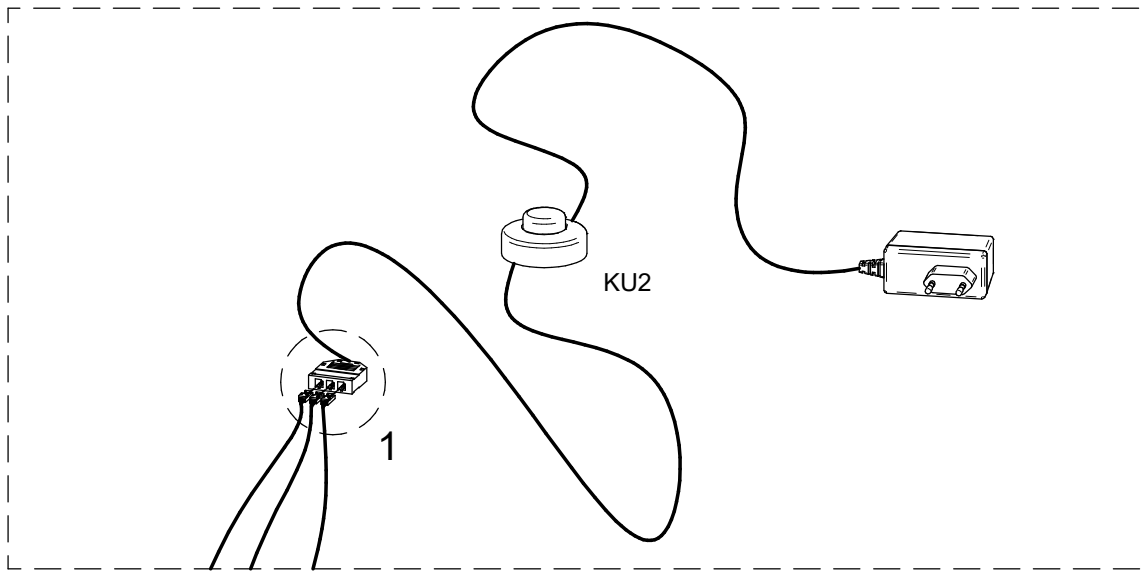

2x

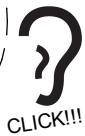
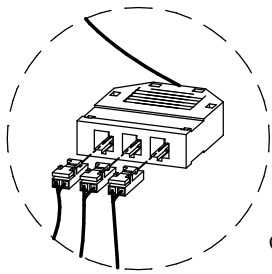

DETAIL 1

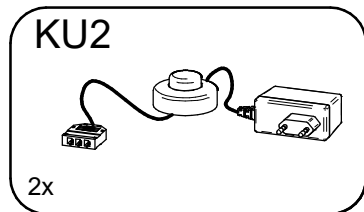

2x

32

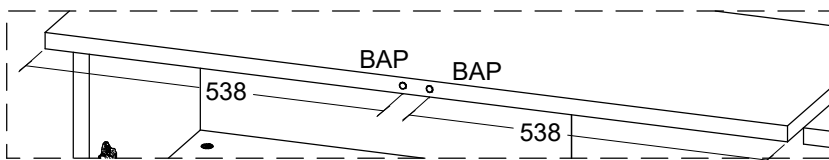
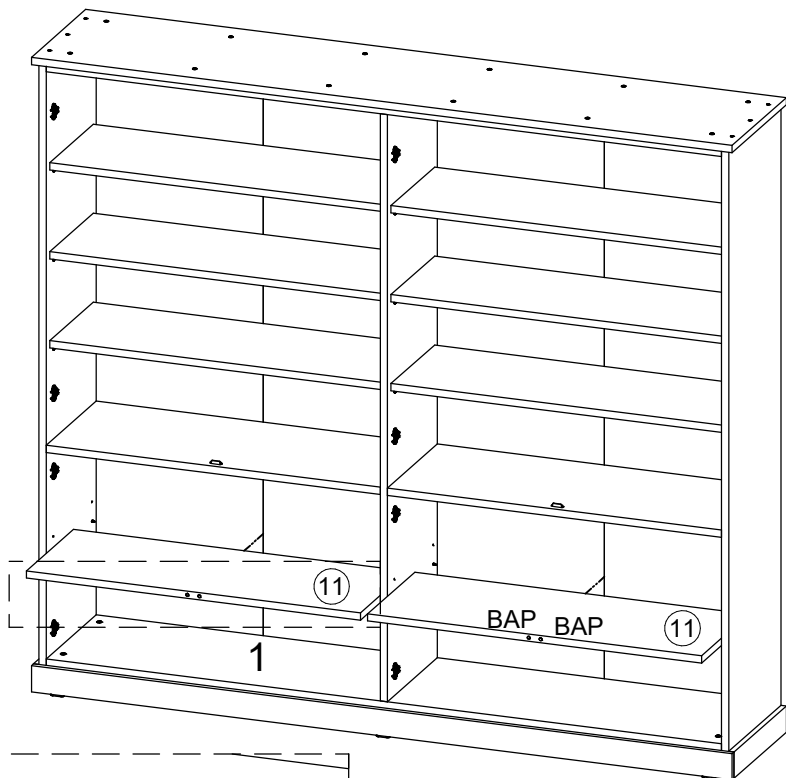

DETAIL 1

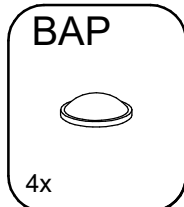

4x

33

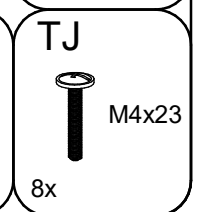
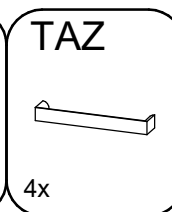
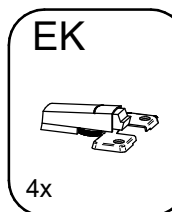
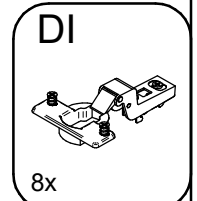
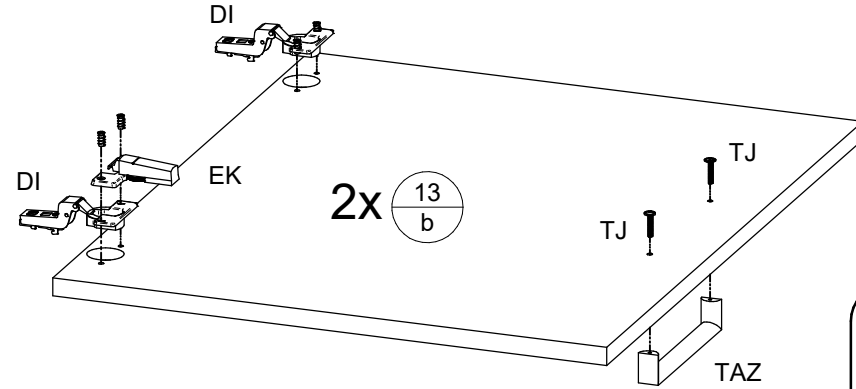
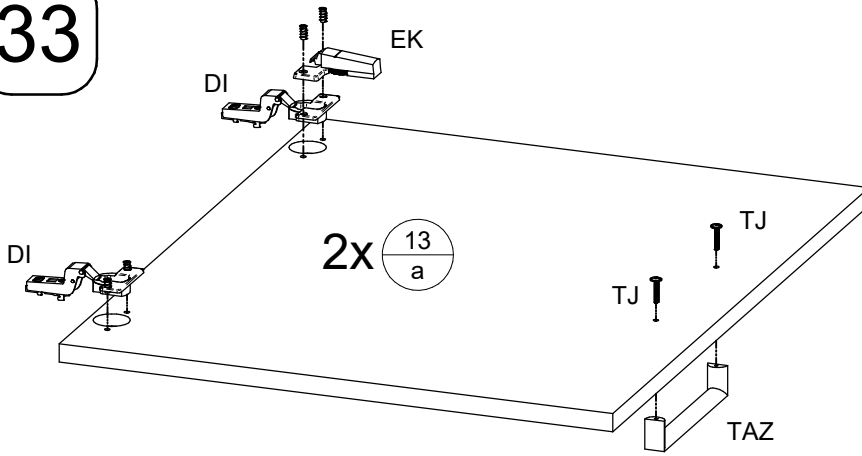



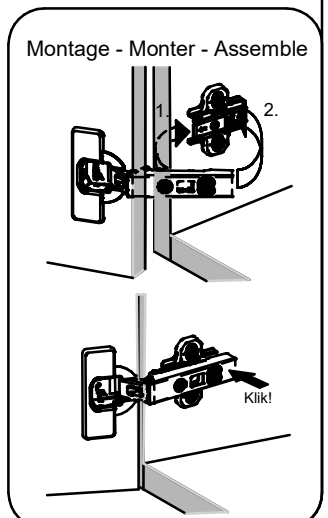
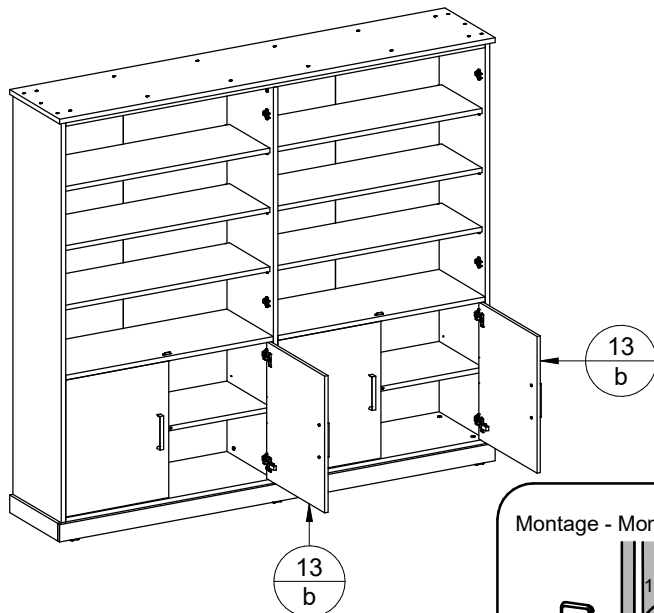
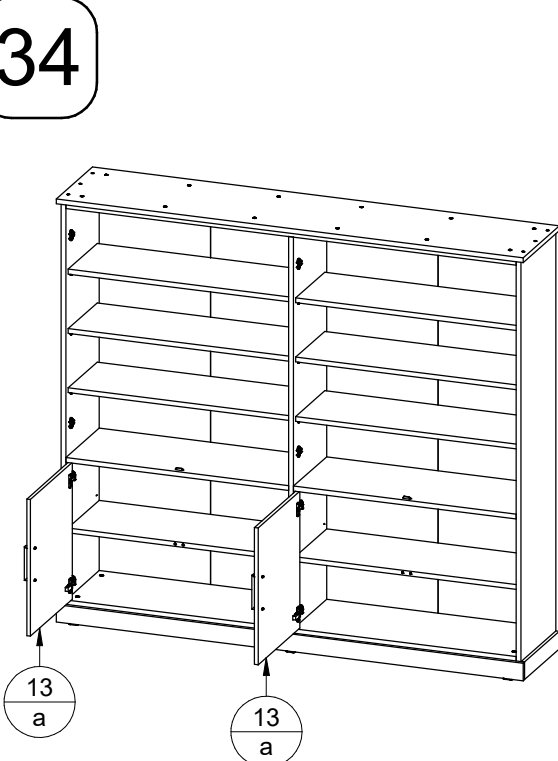

34

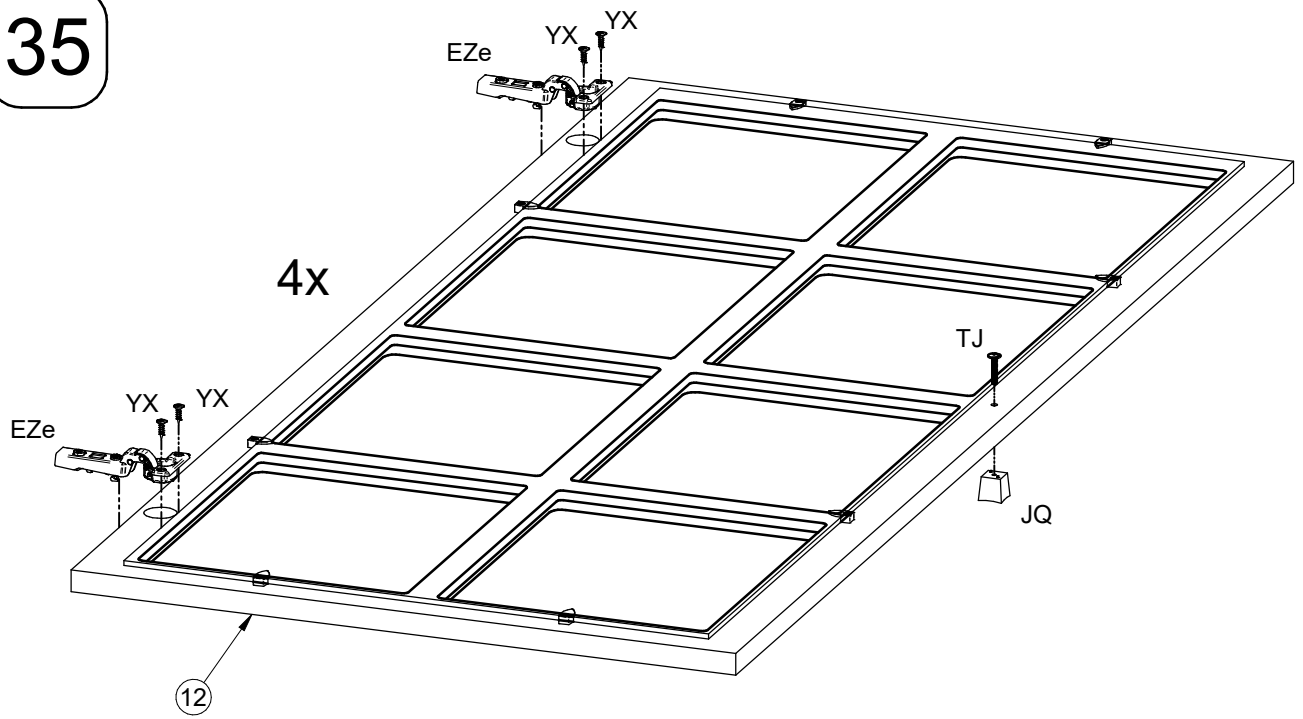

35



<p>EZe</p>  <p>8x</p>	<p>TJ</p>  <p>M4x23</p> <p>4x</p>	<p>JQ</p>  <p>4x</p>	<p>YX</p>  <p>4x16</p> <p>16x</p>
---	---	--	---

36

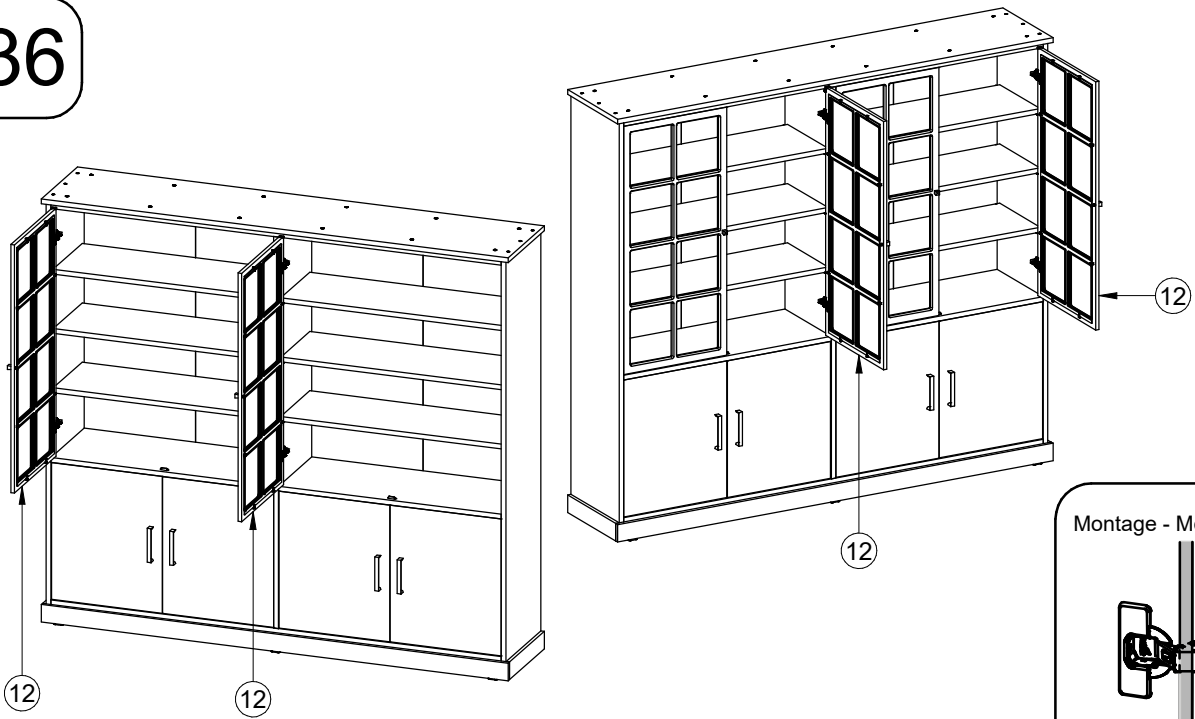

Montage - Monter - Assemble

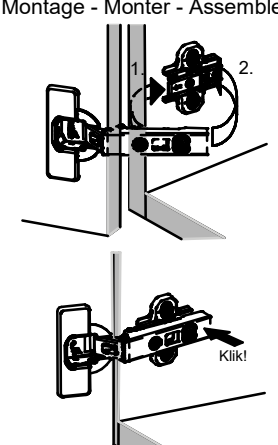

1

2.

Klik!

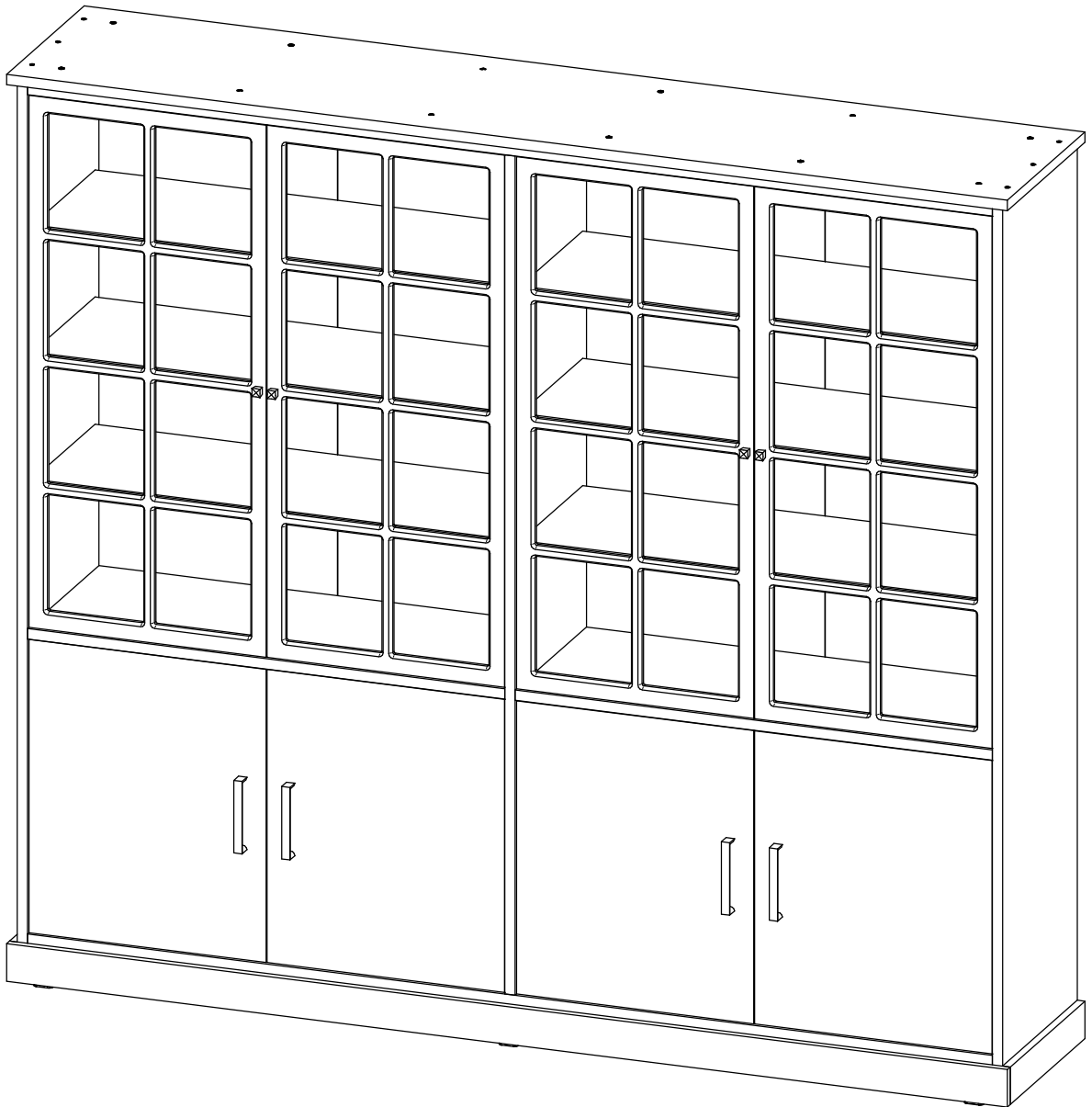

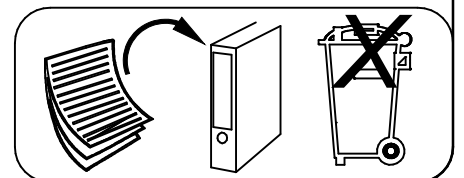
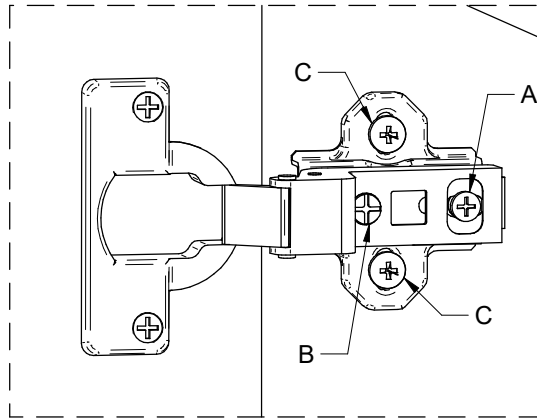
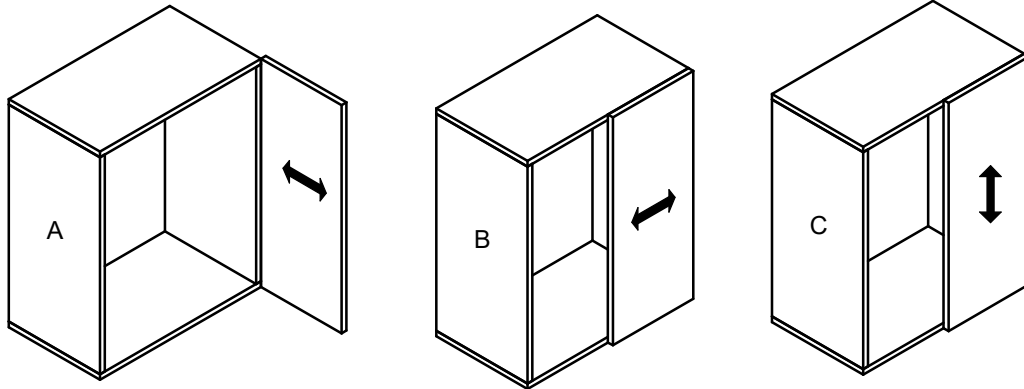

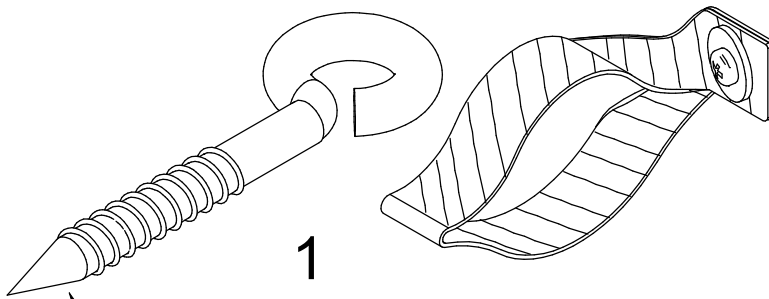
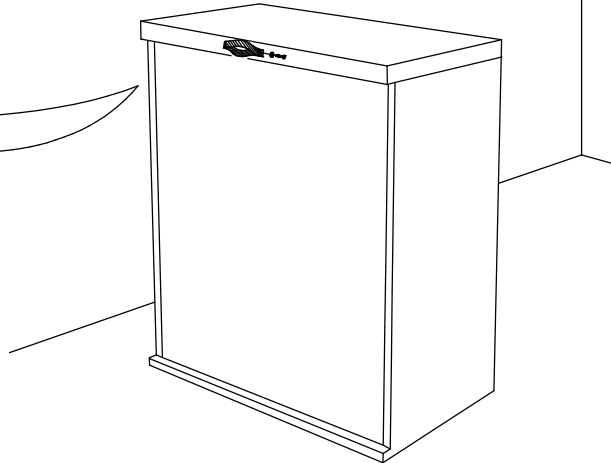
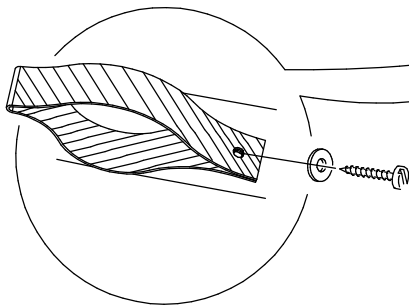
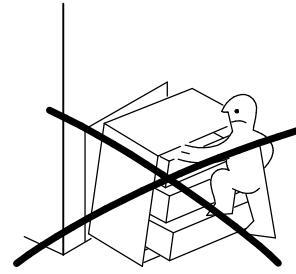
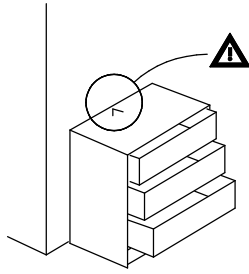
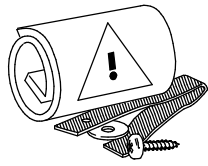
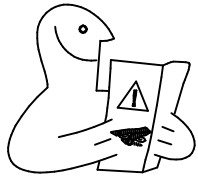

1

Niet inbegrepen
Non fournis
Not included

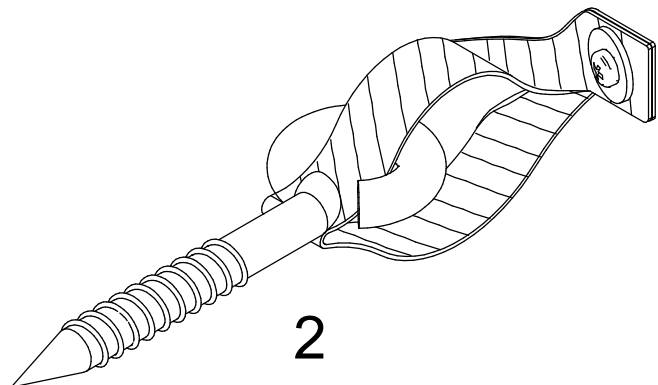

2

Onderhoud - Entretien - Maintenance

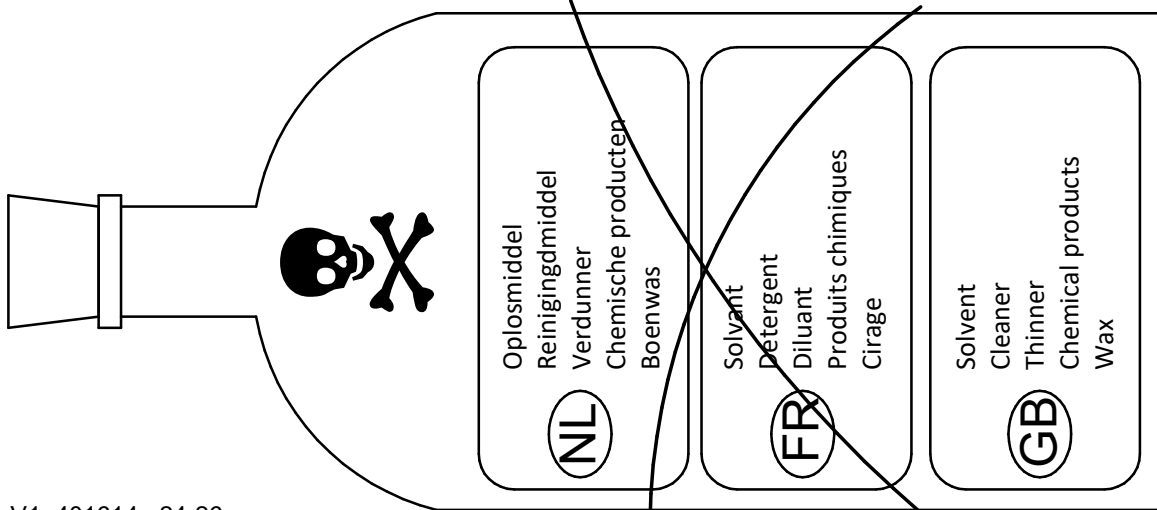

Algemene Informatie: Voor tafels geldt geen hete pannen, thee/glazen en waxinelichtjes op de ondergrond plaatsen. Gebruik hiervoor altijd een onderzetter. Het meubel leegmaken en niet verstepen op de vloer bij eventuele verplaatsing.

Onderhoud: Met licht vochtige doek reinigen en hierna direct droog wrijven. Vocht op het bovenblad direct opnemen. De meubels zijn niet voor vochtige ruimten bestemd. Gebruik nooit een schuurspons, schuurmiddel, amoniak, oplosmiddel, reinigingsmiddel, verdunner, chemische producten, boenwas of producten zoals Pledge-was of dergelijke. Montage tekening opbergen.

Service na verkoop: Voor service na verkoop, ga naar uw leverancier met deze montage tekening.

Garantie: Het niet naleven van deze onderhoudsvoorschriften doet de garantie met onmiddellijke ingang verloren gaan.

NL

L'information générale: Ne mettez jamais des casseroles chaudes, des verres à thé sur la surface des tables. Veuillez utiliser des sous verres. Videz le meuble avant tout déplacement. Portez le meuble et non pas le pousser sur le sol!

Entretien: Utilisez un chiffon légèrement humide et séchez aussitôt. Toute trace de liquide doit être enlevé immédiatement.

Les meubles ne sont pas adaptés aux pièces humides. N'utilisez jamais des éponges abrasives, amoniac, solvant, détergent, diluant, produits chimiques, cirage, des produits d'entretien comme Pledge etc.... . Notice de montage à conserver.

Service après-vente : Pour tout service après-vente, rendez vous au magasin avec cette notice.

Garantie: Nous vous informons qu'en cas de non respect aux prescriptions sus - mentionnés que la garantie expire immédiatement.

FR

General information: Never put hot items on the table tops!
Empty furniture before moving it and do not drag the furniture over the floor.

Maintenance: Clean with slightly wet moistened cloth, wipe dry immediately. Wipe off wetness at once. Not suited for humid locations. Never use solvent, cleaner, thinner, chemical products or wax. Retain manual instruction.

For the after sales: For the after sales, go back to the shop with this assembly instruction.

Guarantee: Attention in case of non respect to the above prescriptions the warranty expires immediately.

GB

Dienst na verkoop

Beste klant,

Wij danken u voor de aankoop van dit meubel.

Ondanks de zorg die wij besteden aan de productie en verpakking van onze meubelen, kan het voorkomen dat er iets ontbreekt of beschadigd is.

Is dit het geval vragen wij u om via bijgaand formulier uw DNV te melden aan de winkel waar u uw meubel heeft aangekocht.

Bij schade vragen wij u ook om volgende:

- 1) een foto van het complete meubel (onderdeel)
- 2) een detailfoto van het probleem

Op die manier kunnen wij u zo vlug mogelijk helpen om uw probleem op te lossen.

Met vriendelijke groet,

Service après vente

Cher client,

Nous vous remercions pour l'achat de ce meuble.

Malgré tout les soins que nous consacrons à la production et le conditionnement de nos meubles, il est possible que quelque chose est manqué ou endommagé.

Si c'est le cas, nous vous demandons d'utiliser le formulaire ci-joint pour déclarer votre plainte au magasin où vous avez acheté vos meubles.

En cas de dommages, nous vous demandons également de prendre les photos suivantes et de nous les envoyer:

- 1) une photo du mobilier complet (partie)
- 2) une photo de détail du problème

De cette façon, nous pouvons vous aider le plus vite possible afin de résoudre votre problème.

Sincèrement,

FORMULIER DNV - FORMULAIRE SAV

Terug te sturen naar uw winkel

A renvoyer à votre magasin

DATUM./DATE :	
UW GEGEVENS / VOS DONNEES	
NAAM/NOM :	
ADRES/ADRESSE :	
E-MAIL:	TEL./GSM

GEGEVENS OVER HET PROBLEEM - DONNEES SUR LE PROBLEME	
Datum aankoop / Date d'achat:	
Naam model en meubelonderdeel Nom modèle et partie du meuble	
Onderdeelnr. of colli nr. (zie het montageplan) N° de pièce ou coli (voir le plan de montage)	
Kleur of stof Couleur ou tissu	
Digitale foto's in bijlage Photos digitales en annexe	JA/OUI <input type="checkbox"/> - NEE/NON <input type="checkbox"/>

<u>Gedetailleerde omschrijving van het probleem :</u> <u>Description détaillée du problème:</u>
--